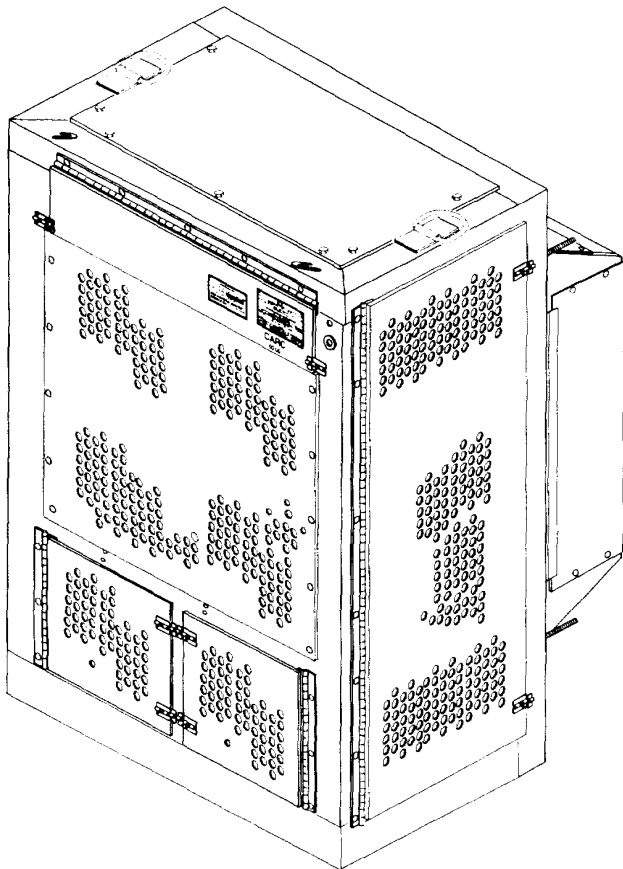


TECHNICAL MANUAL

**OPERATOR'S, UNIT, DIRECT SUPPORT,
AND GENERAL SUPPORT MAINTENANCE MANUAL**



**REFRIGERATION UNIT, MECHANICAL,
10K BTU, ELECTRIC
MODEL F1000RE**

(4110-01-389-9182)

OPERATING INSTRUCTIONS	2-1
OPERATOR PREVENTIVE MAINTENANCE CHECKS AND SERVICES (PMCS)	2-6
UNIT MAINTENANCE INSTRUCTIONS	4-1
UNIT PREVENTIVE MAINTENANCE CHECKS AND SERVICES (PMCS)	4-9
UNIT TROUBLESHOOTING	4-21
DIRECT SUPPORT MAINTENANCE INSTRUCTIONS	5-1
GENERAL SUPPORT MAINTENANCE INSTRUCTIONS	6-1
MAINTENANCE ALLOCATION CHART	B-1

DISTRIBUTION STATEMENT A: Approved for public release; distribution is unlimited.

HEADQUARTERS, DEPARTMENT OF THE ARMY

5 JANUARY 1996

WARNING

- High voltage and exposed rotating parts are contained in the refrigeration unit. Personal injury can result if access doors are open when power is connected.
- Dangerous chemical refrigerant under pressure is used in the refrigeration unit. Sudden and irreversible tissue damage can result from contact with liquid refrigerant. When exposed to high heat or flame, irritating, toxic, and corrosive gases may be released. Wear gloves and a face protector or safety glasses in any situation where skin or eye contact with refrigerant is possible. Do not allow refrigerant to come in contact with high heat or flame. All refrigerant must be discharged from the system and the entire system must be purged with dry nitrogen before beginning any brazing operation.
- Do not attempt any disassembly of refrigerant system components with a refrigerant charge in the system. Refrigerant will be sprayed out dangerously.
- Never introduce high discharge pressure into a refrigerant cylinder. This can cause the cylinder to rupture and injure personnel.
- Never pressurize refrigerant lines with oxygen, mixture with oil could cause an explosion.
- Nitrogen is an inert gas that can cause suffocation and must be discharged in a well ventilated area.
- The pressure in a nitrogen cylinder can exceed 2000 psi. A nitrogen pressure regulator should be used at all times to avoid personal injury.
- Acetone and methyl-ethyl ketone (MEK) are flammable and their vapors can be explosive. Repeated or prolonged skin contact or inhalation of vapors can be toxic. Use in a well ventilated area, wear gloves, and keep away from sparks or flame.
-
- Solder, brazing alloys, and flux contain materials which are hazardous to health. Avoid breathing vapors or fumes from soldering or brazing operations. Perform operations only in well-ventilated areas. Wash hands with soap and water after handling solder, brazing alloys, or flux. Wear thermal gloves and protective goggles or face shield to protect against burns.
-
- Compressor lubricating oil used in this refrigeration system is caustic. Wear gloves and a face protector or safety glasses in any situation where skin or eye contact is possible. If oil does contact skin, wash with soap and water.

a/(b blank)

CHANGE
NO. 1

HEADQUARTERS, DEPARTMENT OF THE ARMY
WASHINGTON, DC, 31 JULY 2005

TECHNICAL MANUAL

OPERATOR'S, UNIT, DIRECT SUPPORT,
AND GENERAL SUPPORT MAINTENANCE MANUAL
FOR
REFRIGERATION UNIT, MECHANICAL,
10K BTU, ELECTRIC
MODEL F10000RE
(4110-01-389-9182)

DISTRIBUTION STATEMENT A: Approved for public release; distribution is unlimited.

TM 9-4110-256-14, 5 January 1996, is updated as follows:

1. File this sheet in front of the manual for reference.
2. This change implements Army Maintenance Transformation and changes the Maintenance Allocation Chart (MAC) to support Field and Sustainment Maintenance.
3. New or updated change information is indicated by a vertical bar in the outer margin of the page.
4. Remove old pages and insert new pages as indicated below:

<u>Remove Pages</u>	<u>Insert Pages</u>	<u>Remove Pages</u>	<u>Insert Pages</u>
	A/(B Blank)		
B-1 through B-10	B-1 through B-10		
2028 Instruction	2028 Instruction		
	Sample DA 2028		
DA 2028	DA 2028		
	DA 2028		
	DA 2028		


ARMY TM 9-4110-256-14

C-1

By Order of the Secretary of the Army:

PETER J. SCHOOMAKER
General, United States Army
Chief of Staff

Official:


SANDRA R. RILEY
*Administrative Assistant to the
Secretary of the Army*
0516408

Distribution: To be distributed in accordance with initial distribution number (IDN) 256314 requirements for TM 9-4110-256-14.

INSERT LATEST CHANGED PAGES. DESTROY SUPERSEDED PAGES.

LIST OF EFFECTIVE PAGES

NOTE: The portion of text affected by the update is indicated by a vertical line in the outer margins of the page. Updates to illustrations are indicated by shaded or screened areas, or by miniature pointing hands.

Dates of issue for original and changed pages / work packages are:

Original .. 0 .. 5 Jan 96
 Change .. 1 .. 31 July 05

TOTAL NUMBER OF PAGES FOR THIS PUBLICATION IS 300, CONSISTING OF THE FOLLOWING:

Page No.	*Change No.
Front Cover	0
a/(b blank)	0
i - vi	0
1-1 through 1- 14	0
2-1 through 2-24	0
3-1 through 3-6	0
4-1 through 4-98	0
5-1 through 5-82	0
6-1/(2 blank)	0
A-1/(2 blank)	0
B-1 though B-10	1
C-1/2	0
D-1/(2 blank)	0
E-1 through (E-4 blank)	0
F-1 through (F-22 blank)	0
G-1/2	0
I-1 through (I-4 blank)	0

***Zero in this column indicates an original page.**

**OPERATOR'S, UNIT, DIRECT SUPPORT AND
GENERAL SUPPORT MAINTENANCE MANUAL
FOR
REFRIGERATION UNIT, MECHANICAL,
10K BTU ELECTRIC, MODEL F10000RE
4110-01-389-9182**

REPORTING ERRORS AND RECOMMENDING IMPROVEMENTS

You can help improve this manual. If you find any mistakes, or if you know of a way to improve these procedures, please let us know. Mail your letter or DA Form 2028 (Recommended Changes to Publications and Blank Forms), or DA Form 2028-2 located in the back of this manual directly to: Commander, US Army Aviation and Troop Command, ATTN: AMSAT-1-MP, 4300 Goodfellow Blvd., St. Louis, MO 63120-1798. You may also submit your recommended changes by E-mail directly to <mpmt%avma28@st-louis-emh7.army.mil>. A reply will be furnished directly to you. Instructions for sending an electronic 2028 may be found at the back of this manual immediately preceding the hard copy 2028.

DISTRIBUTION STATEMENT A: Approved for public release; distribution is unlimited

TABLE OF CONTENTS

	Page
CHAPTER 1	INTRODUCTION 1-1
Section I	General Information 1-1
Section II	Equipment Description 1-3
Section III	Principles of Operation 1-6
CHAPTER 2	<u>OPERATING INSTRUCTIONS</u> 2-1
Section I	Description and Use of Operator's Controls and Indicators 2-2
Section II	<u>Preventive Maintenance Checks and Services (PMCS)</u> 2-6
Section III	Operation Under Usual Conditions 2-19
Section IV	Operation Under Unusual Conditions 2-24
CHAPTER 3	OPERATOR MAINTENANCE INSTRUCTIONS 3-1
Section I	Lubrication 3-1
Section II	Troubleshooting Procedures 3-2
Section III	Operator's Maintenance Procedures 3-5

TABLE OF CONTENTS - Continued

CHAPTER 4 **UNIT MAINTENANCE INSTRUCTIONS**..... 4-1

 Section I Repair Parts, Tools, Special Tools, Test, Measurement, and Diagnostic Equipment (TMDE), and Support Equipment..... 4-1

 Section II Service Upon Receipt..... 4-1

 Section III **Unit Preventive Maintenance Checks and Services (PMCS)** 4-9

 Section IV **Troubleshooting Instructions** 4-21

 Section V Unit Maintenance Instructions 4-25

 Section VI Preparation for Storage or Shipment 4-95

CHAPTER 5 **DIRECT SUPPORT MAINTENANCE INSTRUCTIONS**..... 5-1

 Section I Direct Support Troubleshooting Instructions 5-1

 Section II Direct Support Maintenance Procedures 5-3

CHAPTER 6 **GENERAL SUPPORT MAINTENANCE INSTRUCTIONS** 6-1

APPENDIX A REFERENCESA-1

APPENDIX B **MAINTENANCE ALLOCATION CHART (MAC)**B-1

 Section I IntroductionB-1

 Section II Maintenance Allocation Chart for Refrigeration UnitB-5

 Section III Tool and Test Equipment Requirements for Refrigeration Unit.....B-10

 Section IV Remarks for Refrigeration Unit.....B-10

APPENDIX C COMPONENTS OF END ITEM (COEI) AND BASIC ISSUE ITEMS LIST C-1

 Section I Introduction C-1

 Section II Components Of End ItemC-1

 Section III Basic Issue Items List C-2

APPENDIX D ADDITIONAL AUTHORIZATION LIST D-1

APPENDIX E EXPENDABLE AND DURABLE ITEMS LISTE-1

 Section I IntroductionE-1

 Section II Expendable and Durable Items List.....E-2

APPENDIX F ILLUSTRATED LIST OF MANUFACTURED ITEMSF-1

 Section IF-1

 Section IIF-1

APPENDIX G MANDATORY REPLACEMENT PARTS..... G-1

LIST OF ILLUSTRATIONS

Figure	Title	Page
1-0	Refrigeration Unit	1-0
1-1	Major Components	1-5
1-2	Electrical System	1-7
1-3	Electrical Schematic	1-8
1-4	Electrical Wiring Diagram	1-9
1-5	Refrigeration System	1-11
1-6	Refrigeration Schematic	1-12
1-7	Air Handling System	1-13
2-1	Operating Controls and Indicators	2-3
2-2	Fault Controls and Indicators	2-5
2-3	Operator PMCS Routing Diagram	2-7
2-4	Operating Controls and Indicators	2-20
2-5	Decals and Instruction Plates (Sheet 1 of 2)	2-22
2-5	Decals and Instruction Plates (Sheet 2 of 2)	2-23
4-1	Wall Opening Dimensions	4-2
4-2	Installation	4-3
4-3	Input Power Connection	4-5
4-4	Refrigeration Valve Settings for Normal Operation	4-6
4-5	Compressor Mount	4-7
4-6	Repeat Cycle Timer Adjustment	4-8
4-7	Lubrication	4-10
4-8	Top Panel.....	4-25
4-9	Condenser Side Doors and Barrel Bolts.....	4-27
4-10	Front Bottom Doors and Barrel Bolts	4-29
4-11	Control Panel Cover, Barrel Bolts, and Door Holder Clips	4-31
4-12	Evaporator Air Outlet Guard.....	4-32
4-13	Evaporator Coil Guard.....	4-33
4-14	Condenser Guard.....	4-34
4-15	Wires Cables and Harnesses.....	4-36
4-16	Circuit Breaker	4-42
4-17	Indicator (LIGHT)	4-44
4-18	Fuses	4-46
4-19	Motor Starter	4-48
4-20	Contactors	4-51
4-21	Control Relays.....	4-53
4-22	Hourmeter	4-55
4-23	Toggle Switch.....	4-57
4-24	Repeat Cycle Timer.....	4-59
4-25	Remote Bulb Thermostat (Temperature Control).....	4-62
4-26	Refrigeration Temperature Gage (Thermometer)	4-66
4-27	Defrost Temperature Switch	4-69
4-28	Power Distribution Block.....	4-71
4-29	Push (Door) Switches	4-73

LIST OF ILLUSTRATIONS - Continued

4-30	AC Motor	4-75
4-31	V Belt	4-78
4-32	Condenser Fan	4-80
4-33	Evaporator Fan	4-81
4-34	Flange Bearings	4-83
4-34	Flange Bearings	4-83
4-35	Pulley	4-85
4-36	Sheave.....	4-87
4-37	Solenoid Valve (Liquid Line)	4-89
4-38	Solenoid Valve (Defrost Line).....	4-90
4-39	Gasket (Heat Shield)	4-93
4-40	Refrigeration System Pump Down.....	4-96
4-41	Compressor Mount	4-97
5-1	Control Panel Cover	5-3
5-2	Circuit Breaker Cover	5-5
5-3	Control Box Cover	5-8
5-4	Fan Drive Shaft	5-9
5-5	Service Manifold Installation	5-11
5-6	Discharging Refrigerant.....	5-14
5-7	Nitrogen Tank Connection	5-16
5-8	Evacuation of Refrigerant System	5-22
5-9	Refrigerant Charging (Total System)	5-25
5-10	Refrigerant Charging (Partial System /Small Quantity Charge)	5-27
5-11	Dehydrator	5-32
5-12	Compound Gage	5-34
5-13	Pressure Gage	5-36
5-14	Strainer	5-38
5-15	Receiver.....	5-39
5-16	Condenser Coil	5-42
5-17	Pressure Regulator Valve	5-43
5-18	Pressure Regulator Valve.....	5-45
5-19	Metal Hose Assembly.....	5-46
5-20	Metal Hose Assembly.....	5-47
5-21	Stop Valve	5-48
5-22	Stop Valve	5-49
5-23	Sight Indicator	5-50
5-24	Solenoid Valve	5-51
5-25	Solenoid Valve	5-53
5-26	Isolation Valves.....	5-55
5-27	Accumulator	5-57
5-28	Tubing And Fittings	5-60
5-29	Heat Exchanger	5-62
5-30	Expansion Valve	5-63
5-31	Evaporator Coil	5-65
5-32	Differential Oil Pressure Switch	5-67
5-33	Du al Pressure Control Switch	5-70
5-34	Compressor (Sheet 1 of 2)	5-73
5-34	Compressor (Sheet 2 of 2)	5-74
5-35	Condenser Frame.....	5-79

LIST OF ILLUSTRATIONS - Continued

C-1	Basic Issue Items	C-2
F-1	Tubing-Copper, Straight Flared, Part Number 12076-3-1000	F-3
F-2	Tubing, Plastic, Part Number 13218E0001-305	F-3
F-3	Gasket, Various	F-3
F-4	Tube Distributor to Tee, Part Number 150K0145	F-4
F-5	Tube, Distributor to Street Elbow, Part Number 150K0146	F-4
F-6	Tube, Copper, Straight, Part Number 150K0159	F-5
F-7	Tube, Heat Exchanger to Accumulator, Part Number 150K0160	F-5
F-8	Tube Copper Straight, Part Number 150K0161	F-6
F-9	Gasket, Side, Part Number 150K0169	F-6
F-10	Gasket, Side, Part Number 150K0170	F-7
F-11	Gasket, Top & Bottom, Part Number 150K0171	F-7
F-12	Gasket, Top & Bottom, Part Number 150K0172	F-7
F-13	Tube, Reducer to Expansion Valve, Part Number 150K0187	F-8
F-14	Tube, Accumulator Inlet, Part Number 150K0196	F-8
F-15	Tube, Reducer to Half Union Flare, Part Number 150K0197.....	F-9
F-16	Tube, Straight Flare One End, Part Number 150K0198-3, -5, -7, and -13	F-9
F-17	Tube, Interchanger to Expansion Valve, Part Number 150K0200	F-10
F-18	Braid, Wire, Tubular, Part Number 150K0201-1 /I	F-10
F-19	Insulation Sleeving	F-11
F-20	Tube, Elbow to Interchanger, Part Number 150K0202	F-11
F-21	Tube, Expansion Valve Equalizer, Part Number 150K0203	F-12
F-22	Capillary, Lines, Part Number 150K0206-1/3 & -5/3	F-12
F-23	Insulation Tubing.....	F-13
F-24	Gasket, Control Box, Top, Part Number 150K0028	F-13
F-25	Gasket, Circuit Breaker Panel, Part Number 150K0031	F-13
F-26	Tube Accumulator to Regulator, Part Number 150K0043	F-14
F-27	Tube, Condenser to Regulator, Part Number 150K0044	F-14
F-28	Tube, Street Elbow to Vibration Absorber, Part Number 150K0045	F-15
F-29	Tube, Receiver Inlet, Part Number 150K0046-1/T	F-15
F-30	Tube, Tee to Hand Valve, Part Number 150K0047	F-16
F-31	Tube, Straight Flare One End, Part Number 150K0048	F-17
F-32	Tube, Sight Glass to Elbow, Part Number 150K0049	F-18
F-33	Tube, Strainer to Solenoid Valve, Part Number 150K0050	F-19
F-34	Tube, Filter Drier Outlet, Part Number 150K0051	F-20
F-35	Tube, Receiver to Filter Drier, Part Number 150K0052	F-21

LIST OF TABLES

Table	Title	Page
2-1	Preventive Maintenance Checks and Services for Model F1000RE	2-8
4-1	Preventive Maintenance Checks and Services for Model F1000RE	4-12
4-2	Semi-Annually Mandatory Replacement Parts.....	4-20
4-3	Wire List	4-38
5-1	Pressure Temperature Relationship of Saturated Refrigerant R-134a	5-29
5-2	Nominal Operating Pressure at Suction and Discharge Shut Off Valves	5-31

HOW TO USE THIS MANUAL

Be sure to read all Warnings before using this equipment.

This manual contains instructions for operation and maintenance of the Refrigeration Unit.

The front cover index of this manual lists the areas of the manual used most often and guides you to those sections.

Follow the black mark on the cover index edge through the pages to the edge mark on the section you want. The subjects on the front cover index are also boxed in the table of content. A detailed alphabetical index is located at the back of the manual.

Chapter 1 - Introduces you to the equipment and gives you information such as weight and dimensions used and general theory of operation including principles of operation.

Chapter 2 - Provides the operator with information necessary to identify and service the equipment. Operating instructions for usual and unusual conditions.

Chapter 3 - Provides operator lubrication tasks, and troubleshooting procedures for identifying common equipment malfunctions. Maintenance procedures for performing operator maintenance tasks.

Chapter 4 - Provides unit maintenance personnel with procedures for lubrication and service upon receipt of equipment and instructions for performing repairs on equipment as authorized by the maintenance allocation chart.

Chapter 5 - Provides direct support maintenance personnel with instructions for performing repairs on equipment as authorized by the maintenance allocation chart.

Chapter 6 - Provides general support maintenance personnel with instructions for performing repairs on equipment ,_J as authorized by the maintenance allocation chart.

Appendix A - Provides a list of frequently used forms and publications referenced or used in this manual.

Appendix B - The maintenance allocation chart identifies repairable components and the maintenance level authorized to perform the repairs.

Appendix C - List of components of end item and basic issue items to help you inventory the equipment.

Appendix D - List additional items that you are authorized for the support of the refrigeration unit.

Appendix E - List expendable and durable items needed to operate and maintain the refrigeration unit.

Appendix F - Provides you with instructions for making items authorized to be manufactured or fabricated at unit, direct support or general support maintenance.

Appendix G - List all mandatory replacement parts.

Glossary - List terms and abbreviations used in this manual and their definitions.

Alphabetical Index - Lists subject matter contained in manual in alphabetical order with the paragraph number.

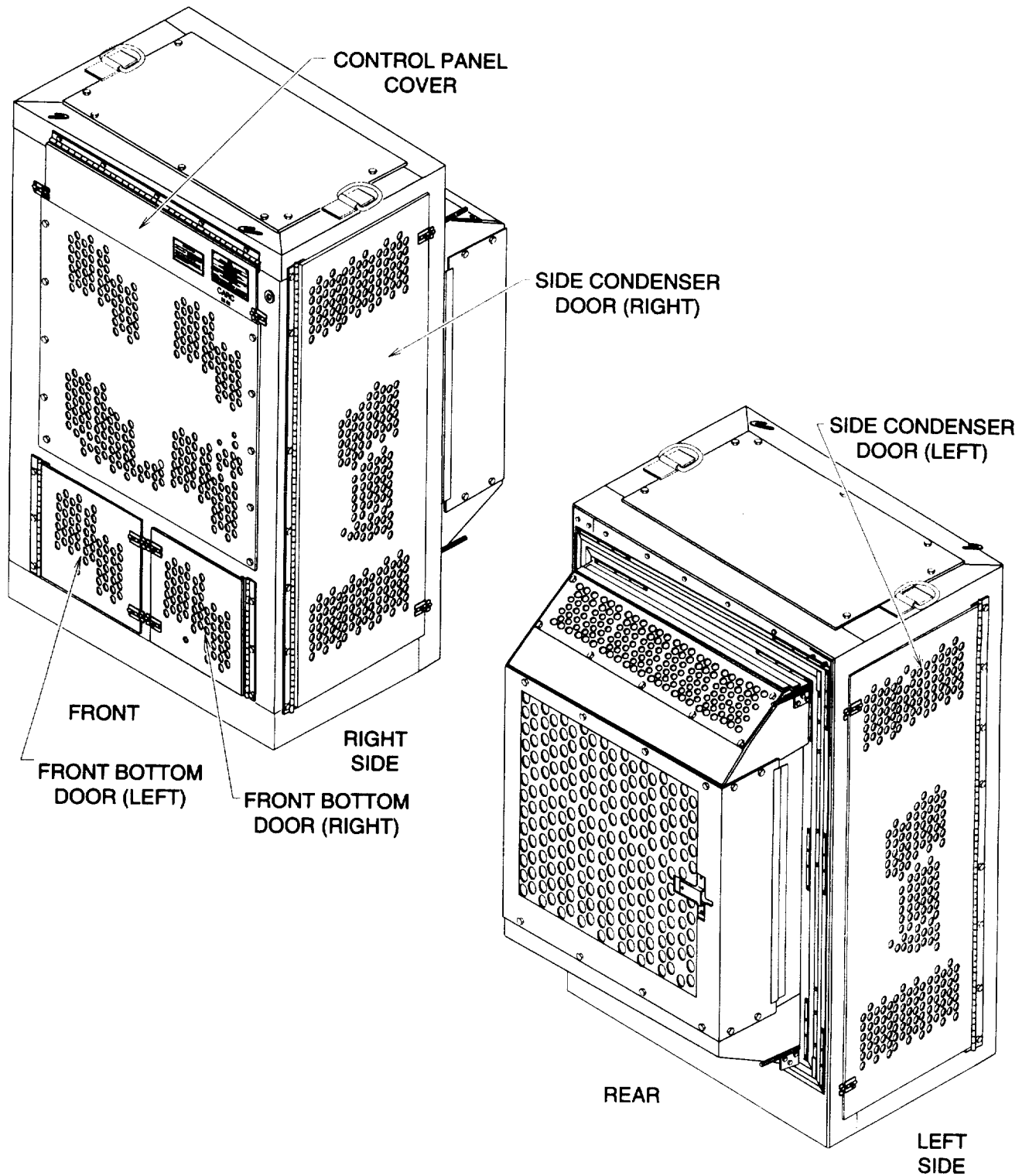


Figure 1-0. Refrigeration Unit

CHAPTER 1

INTRODUCTION

SECTION I GENERAL INFORMATION

1-1. SCOPE.

- a. Type of Manual. Operator's, Unit, Direct Support and General Support Maintenance Manual.
- b. Model Number and Equipment Name. The Model F1000RE, Mechanical, Electric motor driven, 10,000 btu per hour Refrigeration Unit.
- c. Purpose of Equipment. The refrigeration unit is intended for world-wide Military field use under adverse climatic and operating conditions without added protection from the elements. In use, the units are mounted with evaporator section extending into the opening provided in prefabricated panel type refrigerators conforming to MIL-R-10932.

1-2. MAINTENANCE FORMS, RECORDS AND REPORTS.

Department of the Army forms and procedures used for equipment maintenance will be those prescribed by DA Pam 738-750, The Army Maintenance Management System.

1-3. DESTRUCTION OF ARMY MATERIAL TO PREVENT ENEMY USE.

Refer to TM 750-244-3 for specific instructions on the destruction of army material to prevent enemy use.

1-4. PREPARATION FOR STORAGE OR SHIPMENT.

Refer to Chapter 4 for specific information under the same heading.

1-5. QUALITY ASSURANCE.

Requirement for specific quality assurance steps are not applicable to this equipment.

1-6. OFFICIAL NOMENCLATURE, NAMES AND DESIGNATIONS.

The following listings include the nomenclature cross-reference list, list of abbreviations, and explanation of terms (glossary) used in this manual.

Nomenclature Cross-Reference List. A shortened nomenclature is used in this manual to make procedures easier for you to read,. A cross-reference between the shortened nomenclature and the official nomenclature is shown in the following table.

Manual Nomenclature	Official Nomenclature
Refrigeration Unit	Refrigeration Unit Mechanical, 10K btu, Electric, Model F1000RE
Refrigerator Enclosure	Prefabricated Panel Type Refrigerator

1-7. REPORTING EQUIPMENT IMPROVEMENT RECOMMENDATIONS (EIR).

If your Electrical Refrigeration Unit needs improvement, let us know. Send us an EIR. You, the user, are the only one who can tell us what you don't like about your equipment. Let us know why you don't like the design or performance. Put it on an SF 368 (Product Quality Deficiency Report). Mail it to:

Commander
U.S. Army Aviation and Troop Command
ATTN: AMSAT-I-MDO
4300 Goodfellow Blvd.
St. Louis, MO 63120-1798

1-8. WARRANTY INFORMATION.

Refer to TB 9-4110-256-24 for specific warranty information.

1-9. CORROSION PREVENTION AND CONTROL.

Corrosion Prevention and Control (CPC) of Army material is a continuing concern. It is important that any corrosion problems with this item be reported so that the problem can be corrected and improvements can be made to prevent the problem in future items.

While corrosion is typically associated with rusting of metals, it can also include deterioration of other materials, such as rubber and plastic. Unusual cracking, softening, swelling, or breaking of these materials may be corrosion problem.

If a corrosion problem is identified, it can be reported using Standard Form 368, Product Quality Deficiency Report. Use of keywords such as "corrosion," "rust," "deterioration," or "cracking" will ensure that the information is identified as a CPC problem.

The form should be submitted to the address specified in DA Pam 738-750.

SECTION II EQUIPMENT DESCRIPTION**1-10. EQUIPMENT CHARACTERISTICS. CAPABILITIES AND FEATURES.**

a. Characteristics. The Keco Model F1000RE, is a self-contained, electric, three phase, motor driven, panel-mounted refrigeration unit used with a prefabricated panel type refrigerator. It requires a 208 /230 volt ac, 50/60 Hertz power source and can be used under adverse climatic and operating conditions without added protection from the elements.

b. Capabilities. The unit is capable of starting and operating in ambient temperature of 0° F to 125° F (-17° C to 52° C) and to automatically maintain a refrigerator temperature of 0° F and 35° F (-17° C and 2° C).

c. Features. The portion of the condensing unit exposed to weather is capable of operating in rainfall of three inches per hour without functional damage or impaired operation. This unit is designed to use R-134a refrigerant.

1-11. LOCATION AND DESCRIPTION OF MAJOR COMPONENTS.

- 1 CONTROL BOX ASSEMBLY. Houses the automatic and manual electrical control components as well as system monitoring gages.
- 2 EVAPORATOR COIL. Absorbs heat from the air being circulated through the refrigerator enclosure causing the low pressure liquid refrigerant in the coil to evaporate.
- 3 COMPRESSOR. Moves the refrigerant through the refrigeration system by raising the pressure of the incoming gas from the evaporator coil and discharging it as a high pressure gas.
- 4 CONDENSER COIL. Releases heat from the high pressure gas coming from the compressor causing the gas to condense into a high pressure liquid.
- 5 AC MOTOR. Drives the air handling components.
- 6 EVAPORATOR FAN. Circulates air through the refrigerator and across the evaporator coil.
- 7 CONDENSER FAN. Circulates ambient, outside air across the condenser coil.
- 8 DUAL PRESSURE CONTROL SWITCH. Provides over/under pressure protection for the refrigeration system. The switch has a manual reset for overpressure conditions.
- 9 DIFFERENTIAL OIL PRESSURE SWITCH. Provides protection against loss of lubricating oil in the compressor. The switch has a manual reset for low oil conditions.

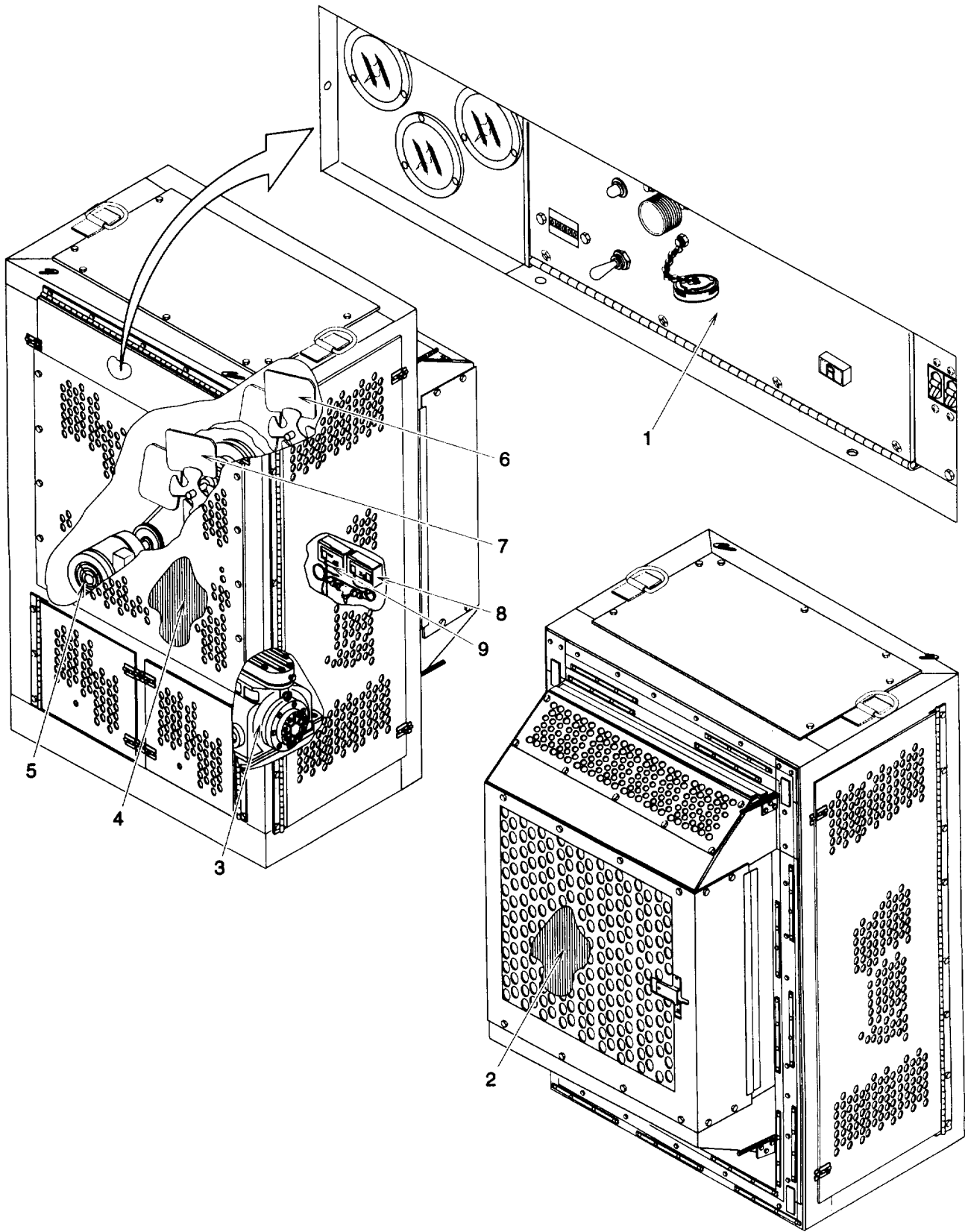


Figure 1-1. Major Components

1-12. EQUIPMENT DATA.

WEIGHTS AND DIMENSIONS

Weight.....	1000 lb (454 Kg)
Width.....	43.75 in. (111.25 cm)
Height	71.01 in. (180.37 cm)
Depth	42.75 in. (108.59 cm)

PERFORMANCE

Cooling Capacity

0° F (-18° C)	10,000 btuh
35° F (2° C).....	18,000 btuh

ELECTRICAL CHARACTERISTICS

Voltage	208/230 Vac
Frequency	50/60 Hz
Current	18 amp

FLUID CAPACITIES

Refrigerant R134a	15 lb (6.8 Kg)
-------------------------	-----------------

SECTION III PRINCIPLES OF OPERATION

1-13. ELECTRICAL SYSTEM.

The refrigeration unit requires electrical power to operate. A power supply cable (not supplied) must be connected between the enclosure assembly and a source of electrical power. The circuit breaker receives power from the enclosure assembly and distributes it to the various components and circuits in the control box assembly. The control box assembly houses various automatic and manual components which control the compressor and ac motor. The compressor causes refrigerant flow through the refrigeration system and the ac motor drives the air handling system.

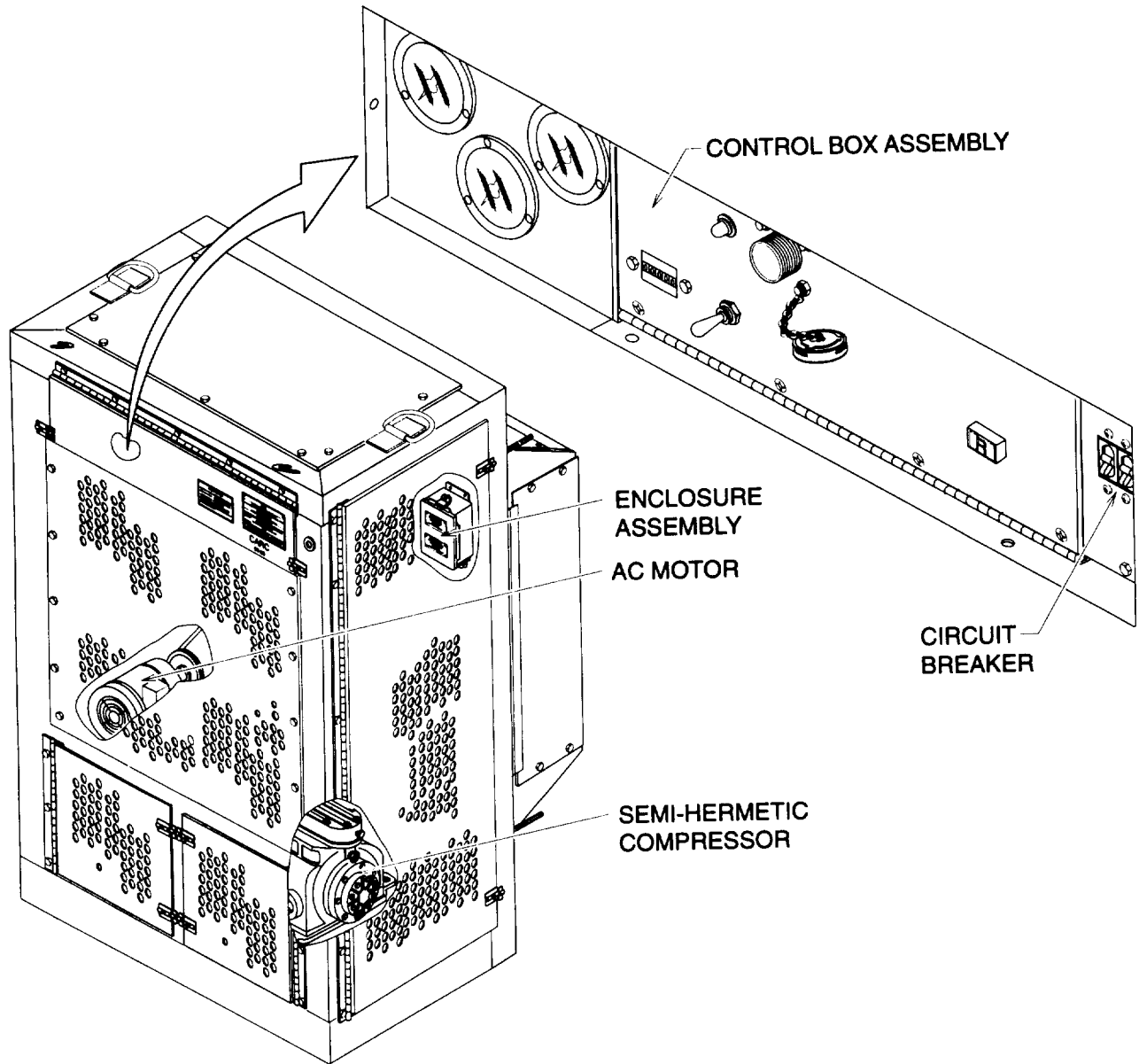
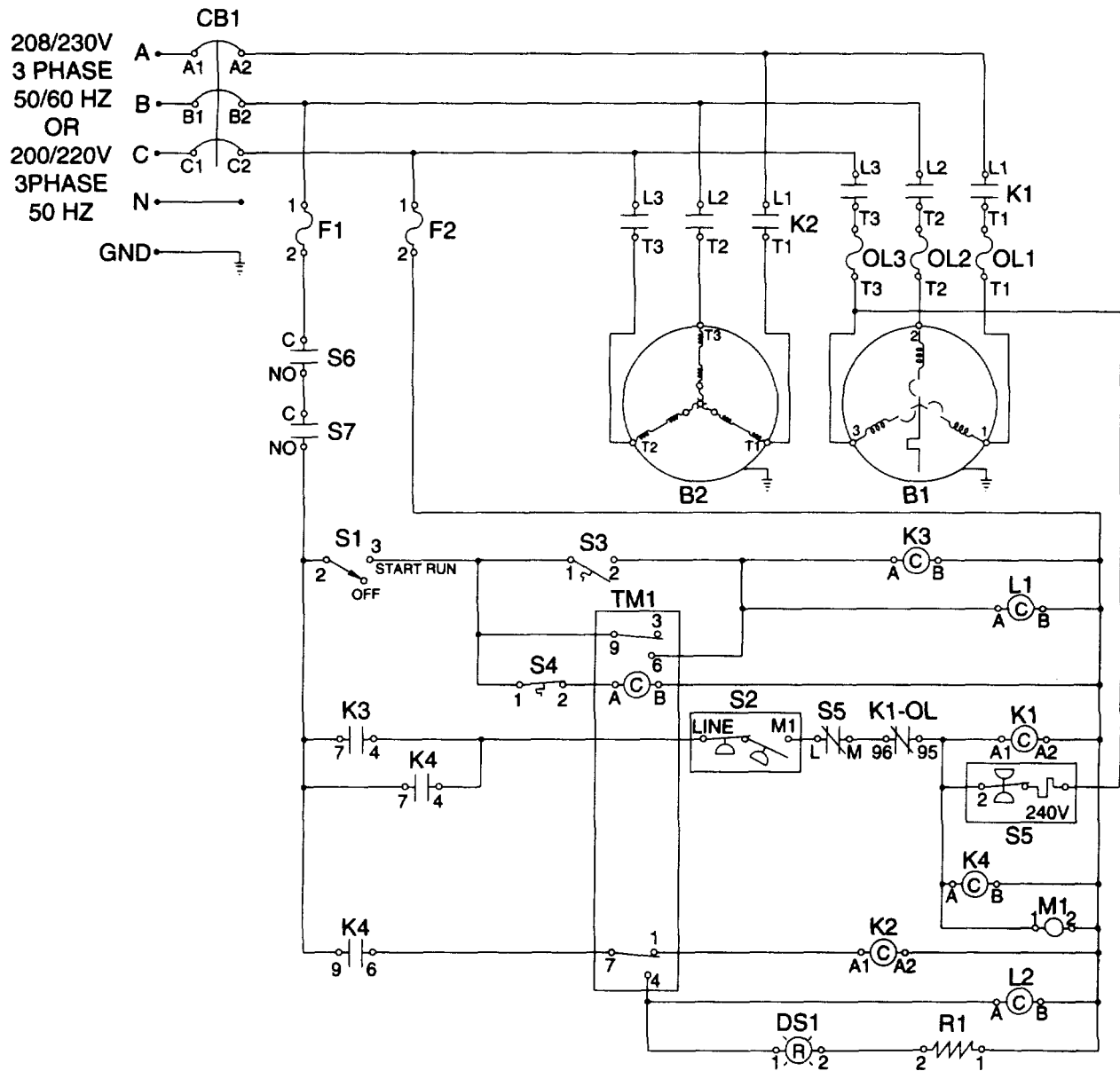
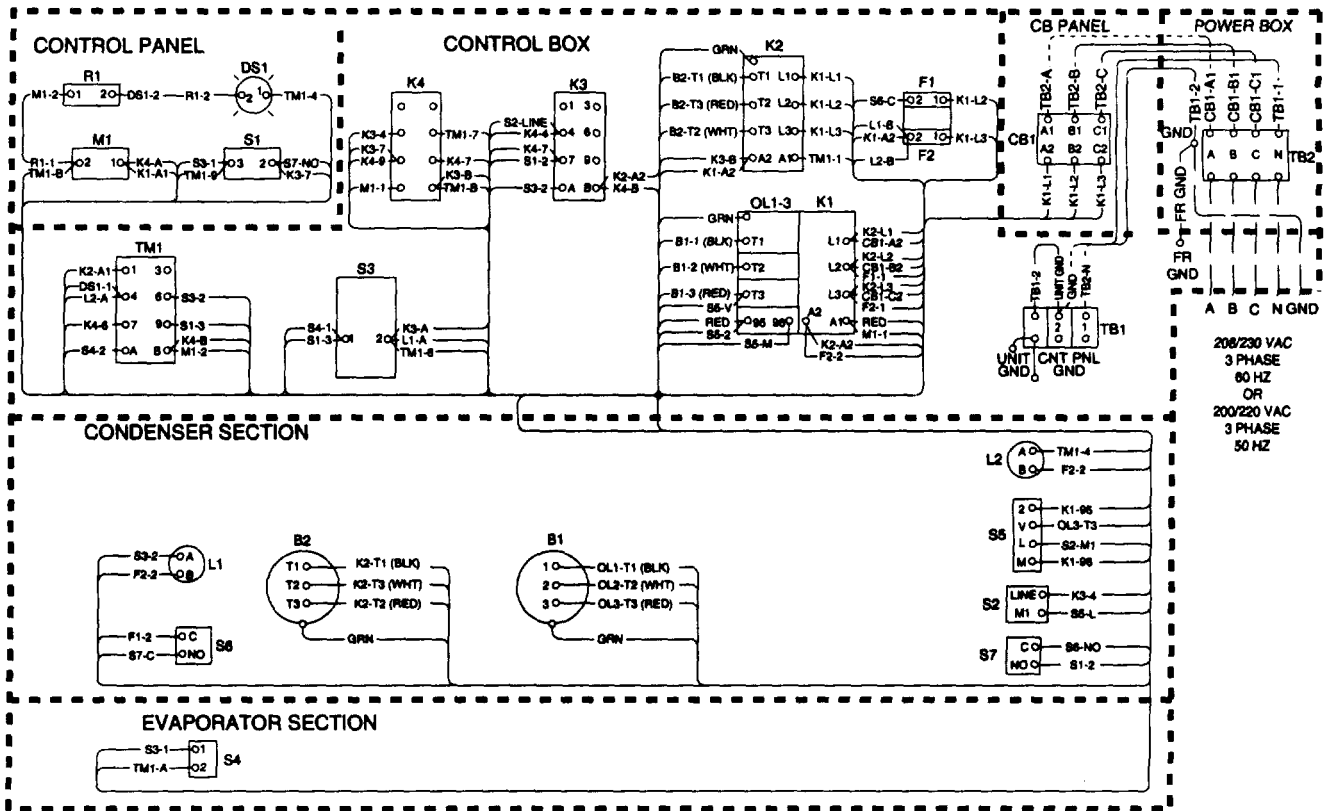


Figure 1-2. Electrical System



LEGEND			
ITEM	DESCRIPTION	ITEM	DESCRIPTION
B1	COMPRESSOR, SEMI-HERMETIC	M1	HOURMETER
B2	MOTOR, A.C. (FAN)	OL1-3	HEATER, OVERLOAD
CB1	CIRCUIT BREAKER (MAIN)	R1	RESISTOR, 10 WATT
DS1	LIGHT, INDICATOR (DEFROST IN PROGRESS)	S1	SWITCH, TOGGLE (START/RUN-OFF)
F1,2	FUSE (6 AMP)	S2	SWITCH, REFRIGERANT PRESSURE
K1	STARTER, MOTOR	S3	THERMOSTAT, REMOTE BULB
K2	RELAY, POWER (FAN)	S4	SWITCH, TEMP (DEFROST TERMINATION)
K3,4	RELAY, CONTROL	S5	SWITCH, DIFFERENTIAL OIL PRESSURE
L1	SOLENOID VALVE, NC (LIQUID LINE)	S6,7	SWITCH, PUSHBUTTON (DOOR)
L2	SOLENOID VALVE, NC (DEFROST)	TM1	TIMER, DEFROST

Figure 1-3. Electrical Schematic



LEGEND			
ITEM	DESCRIPTION	ITEM	DESCRIPTION
B1	COMPRESSOR, SEMI-HERMETIC	M1	HOURLMETER
B2	MOTOR, A.C. (FAN)	OL1-3	HEATER, OVERLOAD
CB1	CIRCUIT BREAKER (MAIN)	R1	RESISTOR, 10 WATT
DS1	LIGHT, INDICATOR (DEFROST IN PROGRESS)	S1	SWITCH, TOGGLE (START/RUN-OFF)
F1,2	FUSE (6 AMP)	S2	SWITCH, REFRIGERANT PRESSURE
K1	STARTER, MOTOR	S3	THERMOSTAT, REMOTE BULB
K2	RELAY, POWER (FAN)	S4	SWITCH, TEMP (DEFROST TERMINATION)
K3,4	RELAY, CONTROL	S5	SWITCH, DIFFERENTIAL OIL PRESSURE
L1	SOLENOID VALVE, NC (LIQUID LINE)	S6,7	SWITCH, PUSHBUTTON (DOOR)
L2	SOLENOID VALVE, NC (DEFROST)	TB1	TERMINAL BOARD
		TM1	TIMER, DEFROST

Figure 1-4. Electrical Wiring Diagram

1-14. REFRIGERATION SYSTEM.

a. Cooling Cycle. Heat is absorbed from the refrigerator enclosure and released to the outside ambient air using refrigerant flowing through the refrigeration system. The compressor moves the refrigerant through the refrigeration system by raising the pressure of the incoming gas from the evaporator coil (evaporator) and discharging it as a high pressure gas. The high pressure gas passes through the condenser coil (condenser) where heat is released to the outside ambient air causing the high pressure gas to condense to a high pressure liquid. The high pressure liquid, which may contain some gas, is collected in the receiver. The receiver contains a dip tube that -L allows only liquid to flow from it. The high pressure liquid passes through the heat exchanger where it is cooled by low pressure gas returning to the compressor. The high pressure liquid passes through the expansion valve (thermostatic expansion valve) which causes a pressure drop and automatically meters the amount of liquid passing through it. The rapid drop in pressure causes the liquid to cool. The cool, low pressure liquid passes through the evaporator coil where heat is absorbed from the refrigerator enclosure air causing the low pressure liquid to evaporate to a low pressure gas. The low pressure gas passes through the heat exchanger where it absorbs heat from the high pressure liquid going into the expansion valve. The low pressure gas, which may contain some liquid, is collected in the accumulator (suction accumulator). The accumulator separates the low pressure gas from any liquid and allows only gas to flow from it. The low pressure gas returns to the compressor to begin the cycle again.

b. Defrost Cycle. By lowering the temperature in the refrigerator enclosure to a temperature below freezing, any moisture that accumulates on the evaporator coil will freeze and prevent proper air circulation through the coil. The defrost cycle is automatically controlled by a temperature sensor and electronic timer in the electrical system. The evaporator coil is defrosted when high pressure gas is sent from the compressor directly into the coil. To prevent water from freezing in the evaporator coil drip pan, the warm high pressure gas tubing is routed through the drain hole in the drip pan. The high pressure gas tubing then serpentine across the bottom of the drip pan before entering the coil. The high pressure gas is then returned to the compressor to begin the cycle again. The defrost cycle will continue until either the temperature sensor or electronic timer terminates it.

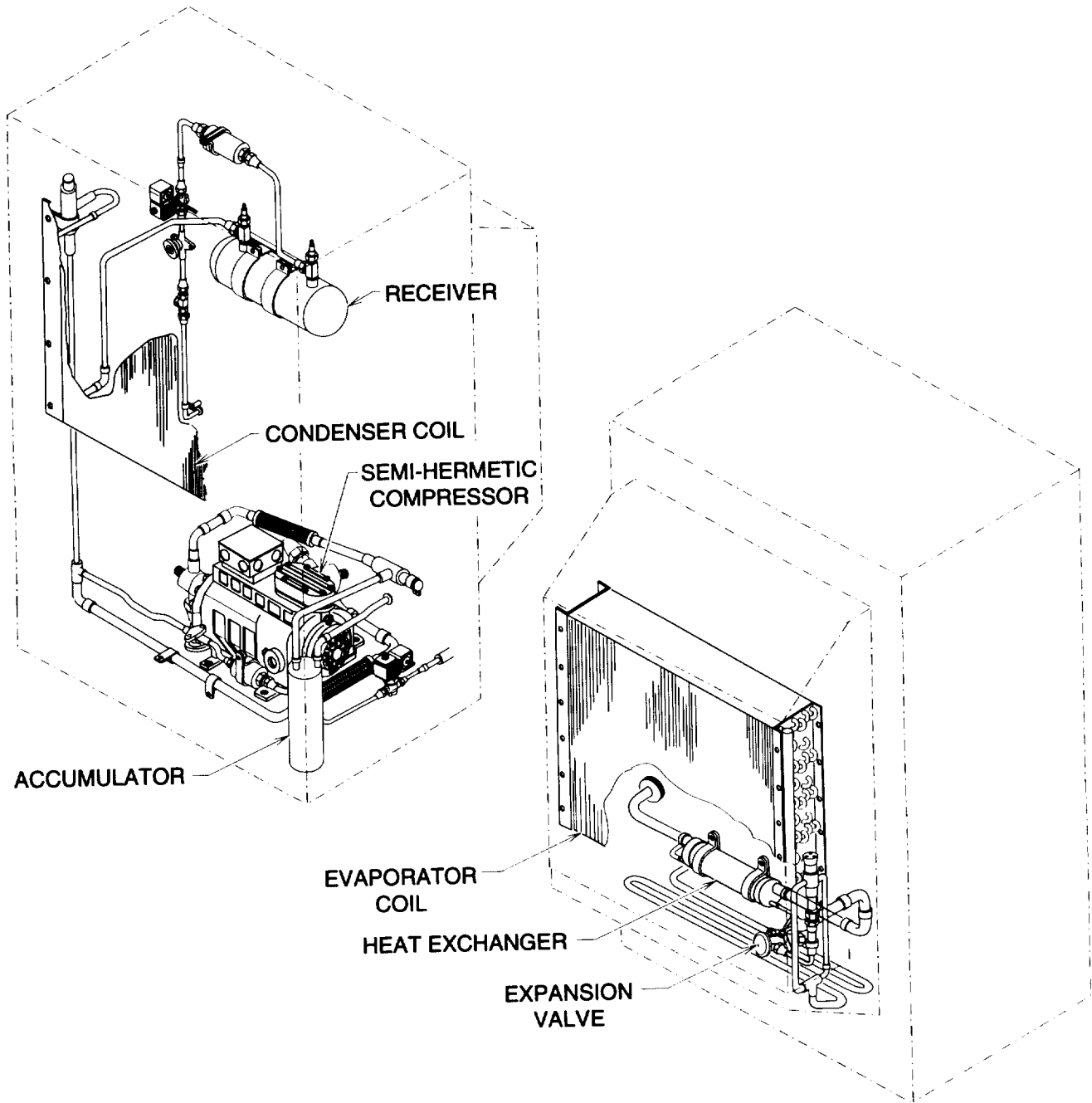
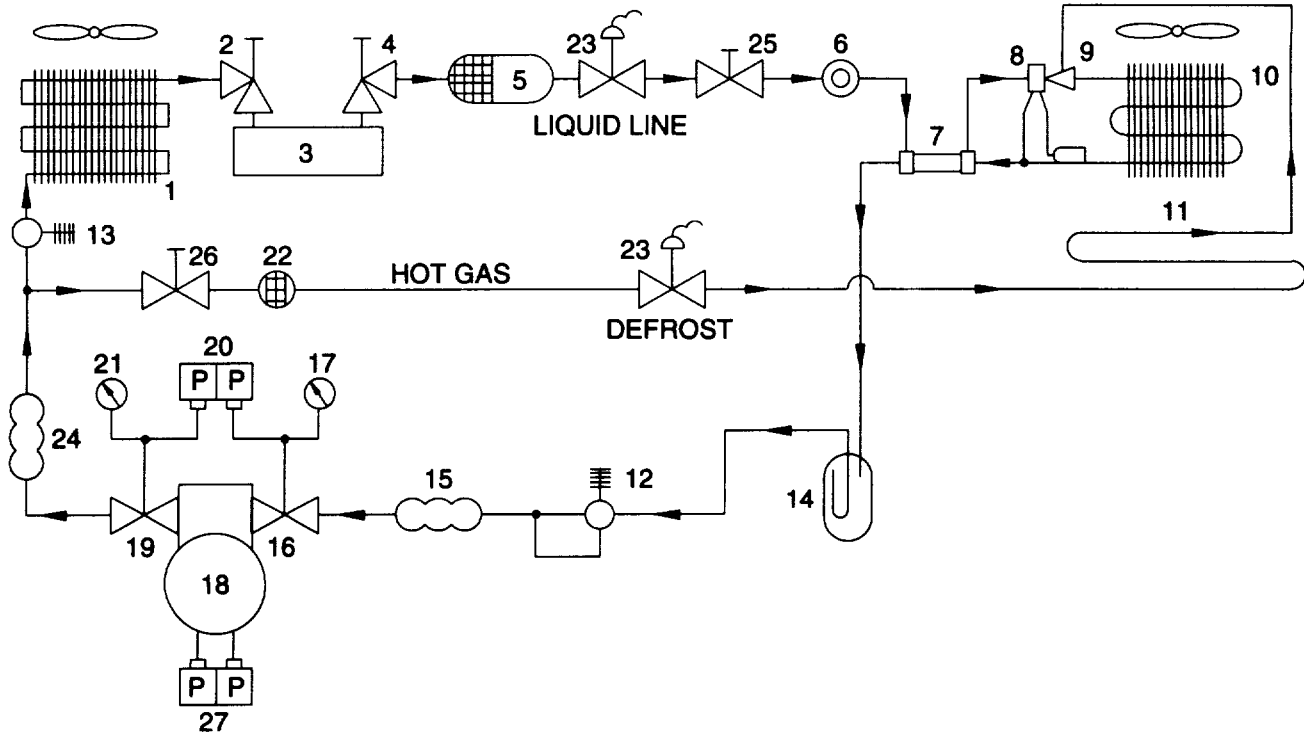


Figure 1-5. Refrigeration System



LEGEND			
ITEM	DESCRIPTION	ITEM	DESCRIPTION
1	CONDENSER	15	VIBRATION ABSORBER
2	SHUT-OFF VALVE	16	SUCTION SERVICE VALVE
3	RECEIVER	17	COMPOUND GAUGE
4	SHUT-OFF VALVE	18	SEMI-HERMETIC COMPRESSOR
5	FILTER DRIER	19	DISCHARGE SERVICE VALVE
6	MOISTURE LIQUID INDICATOR	20	DUAL PRESSURE CUTOUT SWITCH
7	HEAT EXCHANGER	21	HEAD PRESSURE GAUGE
8	THERMOSTATIC EXPANSION VALVE	22	STRAINER
9	DISTRIBUTOR	23	SOLENOID VALVE
10	EVAPORATOR	24	VIBRATION ABSORBER
11	DRAIN PAN COIL	25	SHUT-OFF VALVE
12	CRANKCASE PRESSURE REGULATOR	26	SHUT-OFF VALVE
13	DISCHARGE PRESSURE REGULATOR	27	DIFFERENTIAL OIL PRESSURE SWITCH
14	SUCTION ACCUMULATOR		

Figure 1-6. Refrigeration Schematic

1-15. AIR HANDLING SYSTEM.

a. Refrigerator Enclosure. To absorb heat and cool the refrigerator enclosure, air must be circulated through the evaporator section of the refrigeration unit. Refrigerator enclosure air is drawn in through the coil guard and evaporator coil by the evaporator fan. The air is discharged through the evaporator air outlet guard back into the refrigerator enclosure.

b. Outside Ambient. To release heat absorbed in the refrigerator enclosure to the outside ambient, air must be circulated through the condenser section of the refrigeration unit. Outside ambient air is drawn in through the condenser guard and condenser coil by the condenser fan. The air is discharged through the side condenser doors and front bottom panels back to the outside ambient.

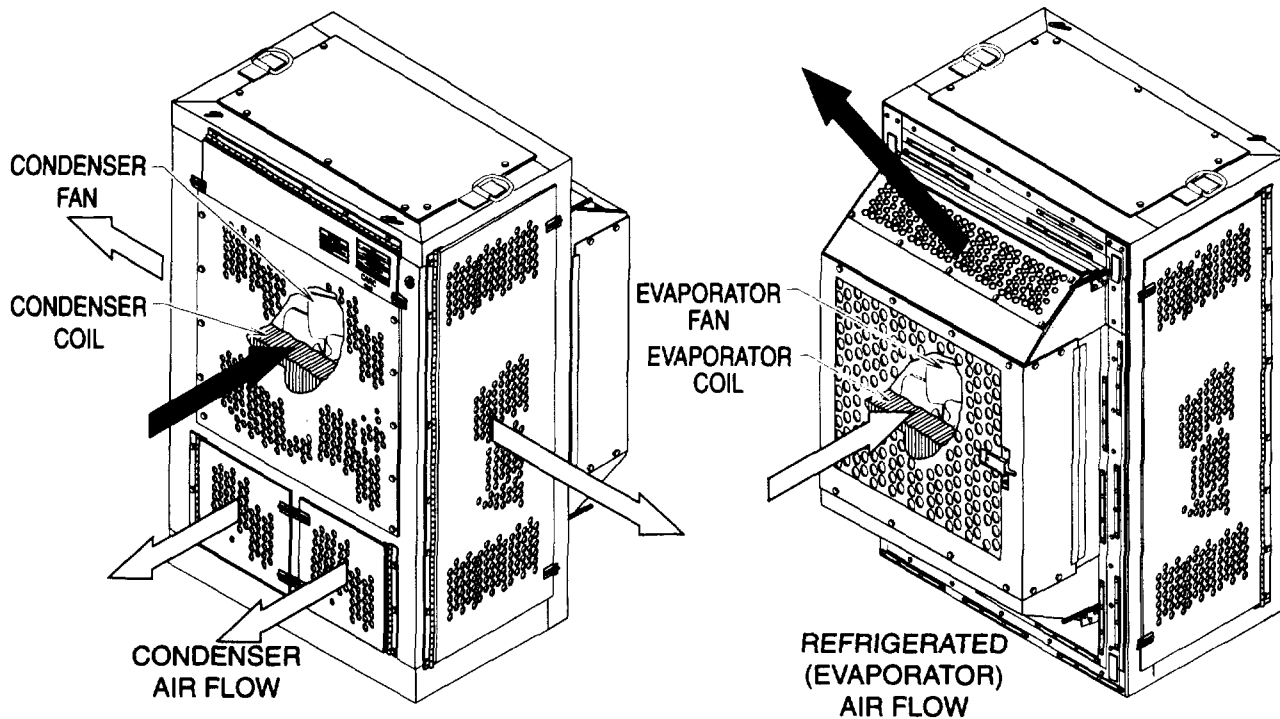


Figure 1-7. Air Handling System

CHAPTER 2
OPERATING INSTRUCTIONS

			Page
SECTION I	DESCRIPTION AND USE OF OPERATOR'S CONTROLS AND INDICATORS		2-1
	2-1 Control Panel Controls and Indicators		2-1
	2-2 Fault Controls and Indicators		2-4
SECTION II	PREVENTIVE MAINTENANCE CHECKS AND SERVICES (PMCS)		2-6
	2-3 General		2-6
SECTION III	OPERATION UNDER USUAL CONDITIONS		2-19
	2-4 Assembly and Preparation for Use		2-19
	2-5 Startup Procedures.....		2-19
	2-6 Operator Checks		2-21
	2-7 Shutdown Procedures.....		2-21
	2-8 Decals and Instruction Plates		2-21
SECTION IV	OPERATION UNDER UNUSUAL CONDITIONS		2-24
	2-9 Operation Under Inclement Weather		2-24
	2-10 NBC Decontamination Procedures.....		2-24

SECTION I DESCRIPTION AND USE OF OPERATOR'S CONTROLS AND INDICATORS

2-1. OPERATING CONTROLS AND INDICATORS.

The controls and indicators needed to operate and monitor the refrigeration unit are located on the control box assembly and inside the condenser frame.

- 1 Circuit Breaker (MAIN CIRCUIT BREAKER). Provides electrical circuit protection for the refrigeration unit. The circuit breaker handle should be in the ON position.
- 2 Remote Bulb Thermostat (TEMPERATURE CONTROL). Monitors and automatically controls the temperature inside the refrigerator enclosure. The remote bulb thermostat should be set to the desired refrigerator enclosure temperature.
- 3 Toggle Switch (START/RUN. OFF). Activates the refrigeration unit. The toggle switch should be in the START/RUN position.

2-1. OPERATING CONTROLS AND INDICATORS. - Continued

- 4 Thermometer (REFRIGERATION TEMPERATURE). Indicates the refrigerator enclosure temperature. The thermometer should indicate within 15° F (-9° C) of the temperature set on the remote bulb thermostat.
- 5 Pressure Gage (DISCHARGE PRESSURE). Indicates the pressure of the refrigerant gas leaving the compressor. The pressure gage should generally indicate between 165 and 250 psi (1138 and 1725 kPa), at start up and/or operation in high temperatures, this range can go higher. The inner scale indicates the temperature of the refrigerant at any given pressure.
- 6 Compound Gage (SUCTION PRESSURE). Indicates the pressure of the refrigerant gas entering the compressor. The compound gage should generally indicate between 0 and 15 psi (0 and 103.5 kPa), at start up and/or operation in low temperatures, this range can go lower. The inner scale indicates the temperature of the refrigerant at any given pressure.
- 7 Sight Indicator (REFRIGERANT SIGHT GLASS). Provides a port through which the refrigerant may be observed as it passes through the liquid line of the refrigeration system. The center indicator changes color as it reacts to moisture in the refrigerant. The sight indicator port should be clear, indicating liquid refrigerant passing through it. An occasional flash of bubbles is normal as the refrigerant system automatically adjusts to changing conditions. The center indicator should be green or chartreuse in color.
- 8 Sight Glass (COMPRESSOR OIL SIGHT GLASS). Provides a port through which the oil level in the compressor may be observed. The sight glass port should show an oil level between 1/4 and 1/2 up the port. Bubbles in or on the oil surface is normal.
- 9 Hourmeter (HOURMETER). Indicates the total number of hours the compressor has operated.
- 10 Indicator (DEFROST IN PROGRESS). Indicates, by illuminating, when the refrigeration unit is operating in a defrost cycle.

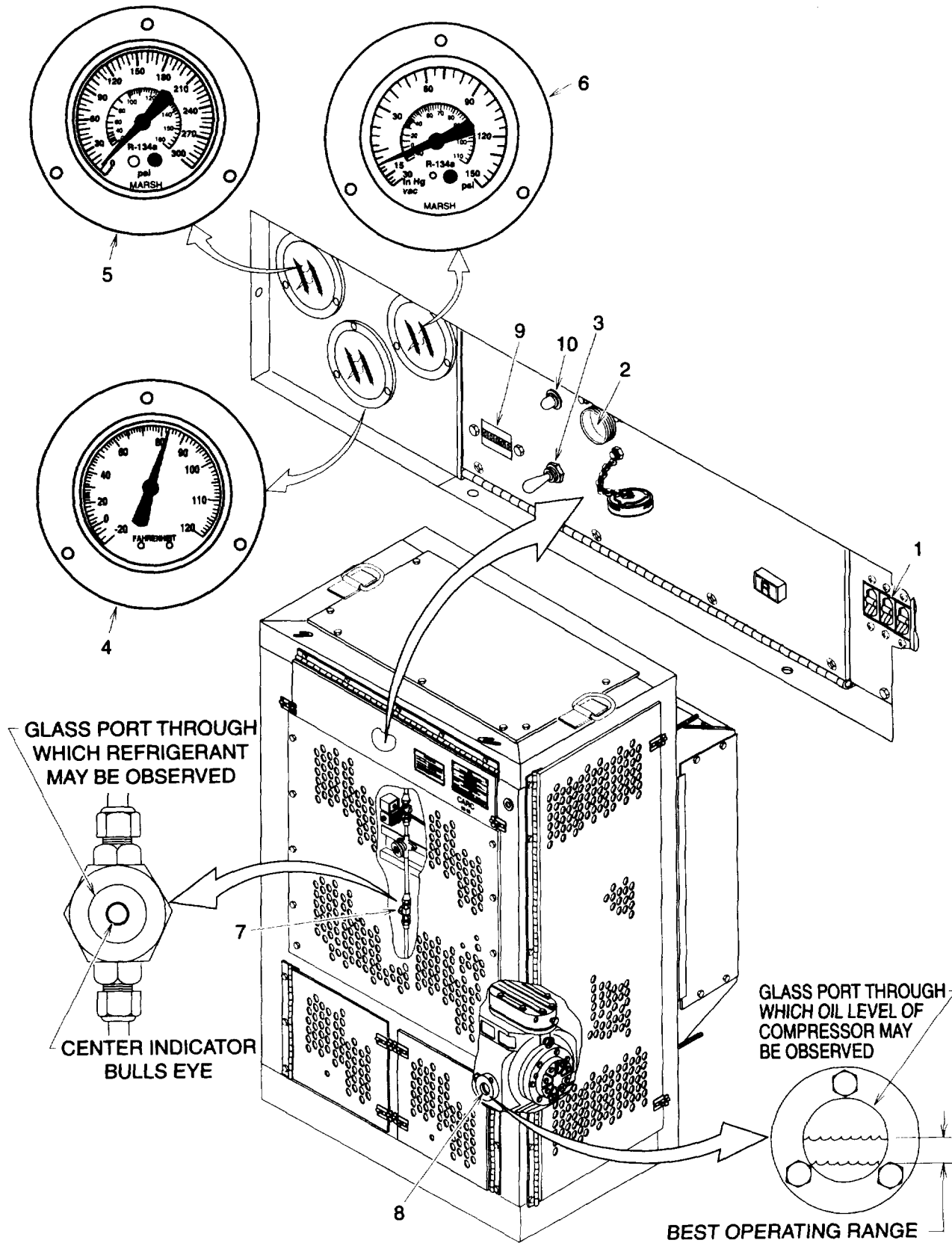


Figure 2-1. Operating Conditions and Indicators

2-2. FAULT CONTROLS AND INDICATORS.

The controls and indicators needed to monitor and reset a fault condition on the refrigeration unit are located on the control box assembly and inside the condenser frame.

- 1 Thermometer (REFRIGERATION TEMPERATURE). The thermometer will indicate more than 15° F (-9° C) above or below the remote bulb thermostat setting if a fault occurs in the temperature control system.
- 2 Pressure Gage (DISCHARGE PRESSURE). The pressure gage will indicate more than 250 psi (1725 kPa) or less than 165 psi (1138.5 kPa) if a fault occurs in the refrigeration system. At start up, shut down, or operation in high temperatures, this range can go higher.
- 3 Compound Gage (SUCTION PRESSURE). The compound gage will indicate more than 15 psi (103.5 kPa) or less than 0 psi (0 kPa) if a fault occurs in the refrigeration system. At start up, shut down, or operation in low temperatures, this range can go lower.
- 4 Circuit Breaker (MAIN CIRCUIT BREAKER). The circuit breaker will be in a mid-way position if a fault has caused excessive load on the electrical system. To reset the circuit breaker, move the handle to the OFF position and then back to the ON position.
- 5 Reset Button (COMPRESSOR OVERLOAD). The reset button resets the motor starter if a fault has caused the compressor to overload. Push the reset button to reset the motor starter.
- 6 Dual Pressure Control Switch. The dual pressure control switch will open the electrical control circuit if a fault in the refrigeration system causes the pressure of the refrigerant gas leaving the compressor to exceed 300 psi (2070 kPa). Push the reset button to reset the dual pressure control switch.
- 7 Differential Oil Pressure Switch. The differential oil pressure switch will open the electrical control circuit if a fault in the refrigeration system causes the compressor oil pressure to drop. Push the reset button to reset the differential oil pressure switch.
- 8 Sight Indicator (REFRIGERANT SIGHT GLASS). The sight indicator port will show continuous bubbles or foam in the refrigerant if there is a fault in the refrigeration system. The center indicator color will be yellow if moisture in the refrigerant exceeds safe operating limits.
- 9 Sight Glass (COMPRESSOR OIL SIGHT GLASS). The sight glass port will show the compressor oil level less than 1/4 up the port or will show the oil foaming if there is a fault in the refrigeration system.

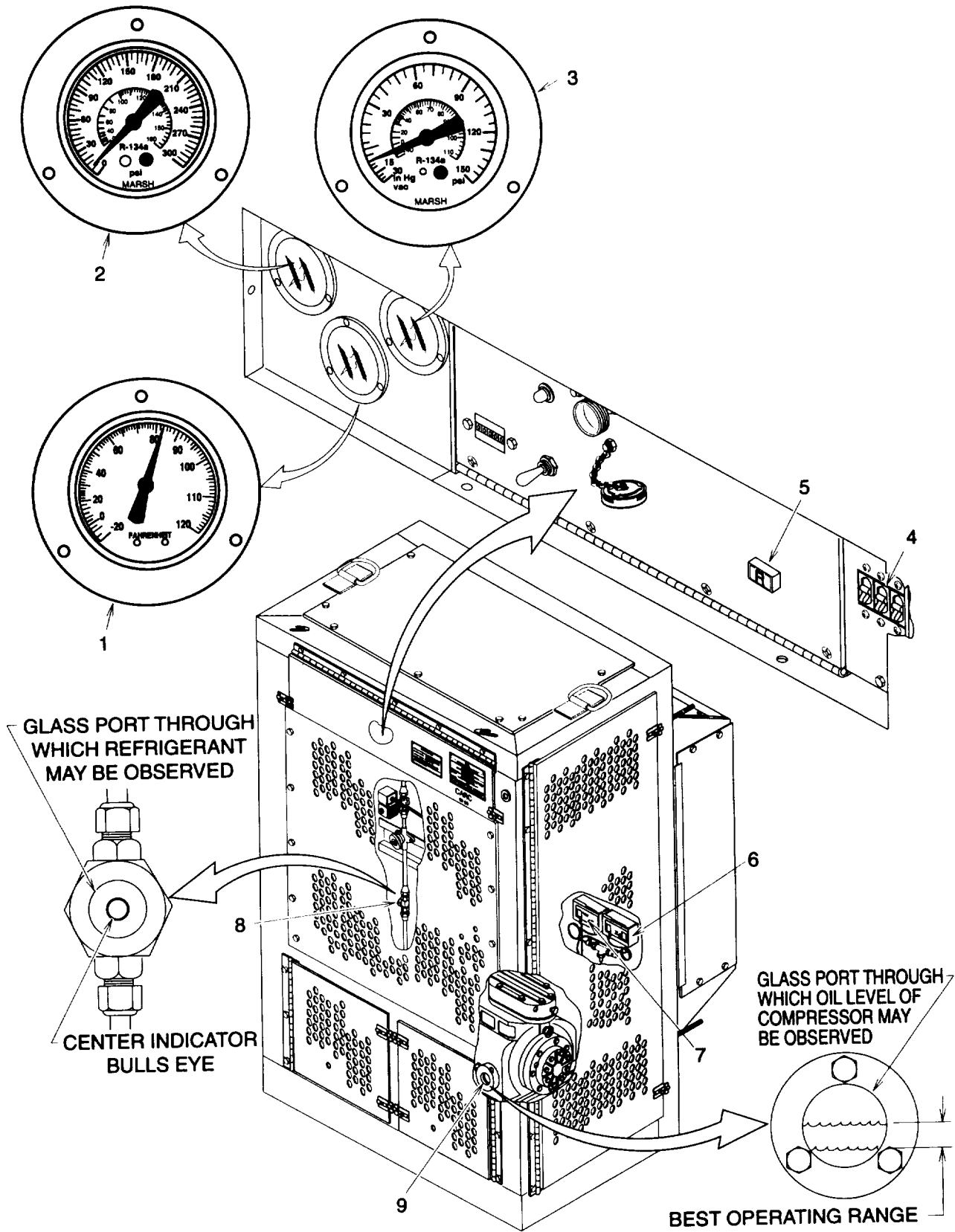


Figure 2-2. Fault Controls and Indicators

SECTION II PREVENTIVE MAINTENANCE CHECKS AND SERVICES (PMCS)**2-3. GENERAL.**

Preventive Maintenance Checks and Services (PMCS) are essential to the efficient operation of the refrigeration unit and to prevent possible damage that might occur through neglect or failure to observe warning symptoms in a timely manner. Checks and services performed by operators are limited to those functions which can be done from the outside of the cabinet. The Preventive Maintenance Checks and Services Table 2-1 lists the inspections and care of the refrigeration unit required to keep it in good operating condition.

a. Warning and Cautions. Always observe the WARNINGS and CAUTIONS appearing in your PMCS Table. Warnings and cautions appear before applicable procedures. You must observe these WARNINGS and CAUTIONS to prevent serious injury to yourself and others or prevent your equipment from being damaged.

b. Explanation of Table Entries.

(1) Item Number Column. Numbers in this column are for reference. When completing DA Form 2404 (Equipment Inspection and Maintenance Worksheet), include the item number for the check/service indicating a fault. Item numbers also appear in the order that you must do checks and services for the intervals listed.

(2) Interval Column. This column tells you when you must do the procedure in the procedure column. BEFORE procedures must be done before you operate or use the equipment for its intended mission. DURING procedures must be done during the time you are operating or using the equipment for its intended mission. AFTER procedures must be done immediately after you have operated or used the equipment. When a check and service procedure is required for both WEEKLY and BEFORE intervals, it is not necessary to do the procedure twice if the equipment is operating during the WEEKLY period.

(3) Location, Check/Service Column. This column provides the location and the item to be checked or serviced. The item location is underlined.

(4) Procedure Column. This column gives the procedure you must do to check or service the item listed in the Check/Service column to know if the equipment is ready or available for its intended mission or for operation. You must do the procedure at the time stated in the interval column.

(5) Not Fully Mission Capable IF: Column. Information in this column tells you what faults will keep your equipment from being capable of performing its primary mission. If you made a check and service procedure that shows faults listed in this column, do not operate the equipment. Follow standard operating procedures for maintaining the equipment or reporting equipment failure.

c. Other Table Entries. Be sure to observe all special information and notes that appear in your table.

d. Refrigerant Leaks. Oil is carried with the refrigerant as it flows through the refrigeration system. If a leak develops in the system, the oil will seep out and soak the copper tubing around the leak or drip and soak or puddle on the frame or other component below the leak. If any oil or seepage is found, a refrigerant leak would be suspected.

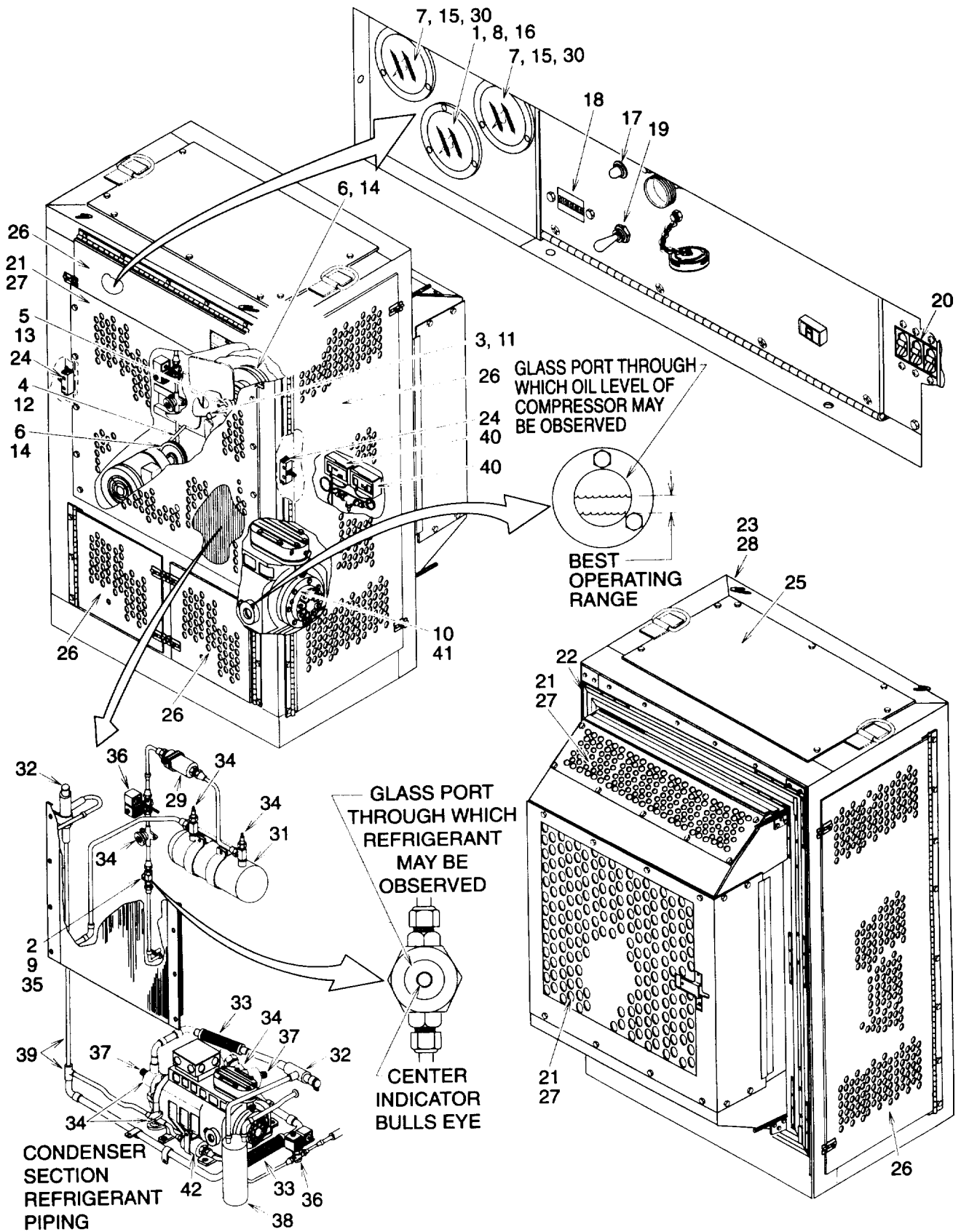


Figure 2-3. Operator PMCS Routing Diagram

Table 2-1. Preventive Maintenance Checks and Services for Model F1000RE

NOTE

If the equipment must be kept in continuous operation, do only the procedures that can be done without disturbing operation. Make complete checks and services when the equipment is shut down.

Location	Interval	Item to Check/Service	Procedure	Not Fully Mission Capable If:
1	Before	<u>Refrigeration Unit Exterior</u> Thermometer <u>Refrigeration Unit Interior</u>	Thermometer should indicate refrigerator enclosure temperature. If it does not, notify unit maintenance to replace it. <p style="text-align: center;"><u>WARNING</u></p> High voltage and exposed rotating parts are contained in the refrigeration unit. Personal injury can result if power is connected with doors open.	Thermometer does not indicate refrigerator enclosure temperature.
2	Before	Sight Indicator	Inspect sight indicator port for cracks and note center indicator color. If cracked or yellow, notify direct support maintenance to replace it or evacuate the refrigeration system as necessary.	Sight indicator port is cracked or center indicator color is yellow.
3	Before	Condenser Fan	Inspect condenser fan for cracks and tears. Inspect for loose connection to fan drive shaft. If damaged or loose, notify unit maintenance to tighten or replace it as necessary.	Fan is cracked, torn, or loose.
4	Before	V Belt	Inspect the V belt for frayed edges, cracks, glazing, or hard brittle condition. Inspect for excessive looseness or slippage. If damaged or loose, notify unit maintenance to tighten or replace it as necessary	V belt is frayed, cracked, glazed, or hard and brittle. V belt is excessively loose or slipping.
5	Before	Flange Bearings	Inspect flange bearings for loose or missing mounting hardware and looseness of fan drive shaft in bearing. If loose, notify unit maintenance to tighten or replace it as necessary.	Flange bearing mounts are loose or fan drive shaft is loose in bearing.

Item No.	Interval	Location	Procedure	Not Fully Mission Capable If:
		Item to Check/Service		
6	Before	Pulleys <u>Refrigeration Unit Exterior</u>	<p>Inspect pulleys for cracks, chips, or warpage. Inspect for secure mounting to shaft. If damaged or loose, notify unit maintenance to tighten or replace it as necessary.</p> <p style="text-align: center;">NOTE</p> <ul style="list-style-type: none"> • The gages must not be inspected when DEFROST IN PROGRESS indicator is on. • Pressures given are the acceptable operating range. 	Pulleys are cracked, chipped, warped, or loose on shaft.
7	During	Gages	<p>Inspect the pressure gage for reading between 165 and 250 psi (1138.5 and 1725 kPa) and the compound gage for reading between 0 and 15 psi (0 and 103.5 kPa). If either gage is out of acceptable operating range on a continuous basis, note the readings and shut down refrigeration unit. Notify unit maintenance of the pressure readings.</p> <p style="text-align: center;">NOTE</p> <p>The thermometer must not be inspected when the DEFROST IN PROGRESS indicator is on.</p>	Gage reading above or below acceptable operating range.
8	During	Thermometer	<p>Thermometer should indicate within 15° F (-9° C) of TEMPERATURE CONTROL setting. If out of this range, shut down refrigeration unit and notify unit maintenance. CONTROL setting.</p>	Thermometer indicates more than 15° F (-9° C) above or below TEMPERATURE

Table 2-1. Preventive Maintenance Checks and Services for Model F1000RE

Item No.	Interval	Location	Procedure	Not Fully Mission Capable If:
		Item to Check/Service		
9	During	Sight Indicator (Refrigerant)	<p style="text-align: center;">NOTE</p> <ul style="list-style-type: none"> • The sight indicator must not be inspected when the DEFROST IN PROGRESS indicator is on. • The sight indicator can be viewed looking through the left side condenser door. <p>Inspect sight indicator port for constant bubbles or foaming and note center indicator color. If constant bubbles or yellow indicator are seen, shut down refrigeration unit and notify direct support maintenance to leak check and evacuate refrigeration system as necessary.</p>	Sight indicator port shows constant bubbles or foam. Center indicator color is yellow.
10	During	Compressor (Oil Level Sight Glass)	<p style="text-align: center;">NOTE</p> <ul style="list-style-type: none"> • The sight glass must not be inspected when the DEFROST IN PROGRESS indicator is on. • The sight glass can be viewed looking through the front bottom panel. • Safe operating level is between 1/4 <p>Inspect the sight glass port for low or high oil level and foaming. If oil level is out of safe operating range or foaming, shut down refrigeration unit and notify direct support maintenance to leak check and add oil to or remove oil from compressor as necessary.</p>	Sight glass port oil level above or below safe operating range or foaming.

Item No.	Interval	Location	Procedure	Not Fully Mission Capable If:
		Item to Check/Service		
		<u>Refrigeration Unit Interior</u>		
11	After	Condenser Fan	<p style="text-align: center;"><u>WARNING</u></p> <p>High voltage and exposed rotating parts are contained in the refrigeration unit. Personal injury can result if power is connected with doors open.</p> <p>Inspect condenser fan for cracks and tears. Inspect for loose connection to fan drive shaft. If damaged or loose, notify unit maintenance to tighten or replace it as necessary.</p>	Fan is cracked, torn, or loose.
12	After	V Belt	Inspect the V belt for frayed edges, cracks, glazing, or hard brittle condition. Inspect for excessive looseness or slippage. If damaged or loose, notify unit maintenance to tighten or replace it as necessary.	V belt is frayed, cracked, glazed, or hard and brittle. V belt is excessively loose or slipping.
13	After	Flange Bearings	Inspect flange bearings for loose or missing mounting hardware and looseness of fan drive shaft in bearing. If loose, notify unit maintenance to tighten or replace it as necessary.	Flange bearing mounts are loose or fan drive shaft is loose in bearing.
14	After	Pulleys	Inspect pulleys for cracks, chips, or warpage. Inspect for secure mounting to shaft. If damaged or loose, notify unit maintenance to tighten or replace it as necessary.	Pulleys are cracked, chipped, warped, or loose on shaft.
		<u>Refrigeration Unit Exterior</u>		
15	Weekly	Gages	Inspect the gages for cracked or missing lens and loose or missing mounting hardware. If damaged or loose, notify unit maintenance to tighten or replace it as necessary.	

Table 2-1. Preventive Maintenance Checks and Services for Model F1000RE

Item No.	Interval	Location	Procedure	Not Fully Mission Capable If:
		Item to Check/Service		
16	Weekly	Thermometer	Inspect the thermometer for cracked or missing lens and loose or missing mounting hardware. If damaged or loose, notify unit maintenance to tighten or replace it as necessary.	
17	Weekly	Indicator	Inspect the indicator for cracked, loose, or missing cap and loose base. Tighten cap if loose. If damaged or base is loose, notify unit maintenance to test, tighten, or replace it as necessary.	
18	Weekly	Hourmeter	Inspect the hourmeter for cracked or missing lens and loose or missing mounting hardware. If damaged or loose, notify unit maintenance to test, tighten, or replace it as necessary.	
19	Weekly	Toggle Switch	<p style="text-align: center;">NOTE</p> <p style="text-align: center;">Operating the toggle switch can cause the refrigeration unit to start or shut down.</p> <p>Inspect the toggle switch for damaged handle and loose or missing mounting hardware. Inspect for smooth operation to START/RUN and OFF. If damaged, loose, or operation is stiff or binding, notify unit maintenance to test, tighten, or replace it as necessary.</p> <p style="text-align: center;">NOTE</p> <p style="text-align: center;">Operating the circuit breaker can cause the refrigeration unit to start or shut down.</p>	Toggle switch will not stay in START/RUN position.
20	Weekly	Circuit Breaker	Inspect the circuit breaker for cracked or damaged handle and loose or missing mounting hardware. Inspect for smooth operation to ON and OFF. If damaged, loose, or operation is stiff or binding, notify unit maintenance to test, tighten, or replace it as necessary.	Circuit breaker will not stay in ON position or handle is damaged.

Table 2-1. Preventive Maintenance Checks and Services for Model F1000RE

Item No.	Interval	Location	Procedure	Not Fully Mission Capable If:
		Item to Check/Service		
21	Weekly	Guards	Inspect the guards for any debris or foreign material obstructing the openings. Remove any debris or foreign material from the guard openings. If debris cannot be removed, notify unit maintenance to remove it.	Debris or foreign material obstructs the guard openings.
22	Weekly	Gasket	Inspect for loose or missing gasket and for splits or tears. If damaged or loose, notify unit maintenance to tighten or replace it as necessary.	
23	Weekly	Condenser Frame	<ul style="list-style-type: none"> a. Inspect the condenser frame for cracks and loose or missing hardware. If cracked, notify direct support maintenance for repair. If hardware is loose or missing, notify unit maintenance to tighten or replace is as necessary. b. Inspect the frame for any chipped or missing paint and evidence of corrosion. If paint is damaged or frame shows evidence of corrosion, notify unit maintenance to paint it. c. Inspect the evaporator housing condensate drain plastic tubing for any debris or foreign material obstructing it. Remove any debris or foreign material from the condensate drain tubing. If tubing cannot be cleaned, notify unit maintenance to clean it. 	Debris or foreign material obstructing the condensate drain opening.

Table 2-1. Preventive Maintenance Checks and Services for Model F1000RE

Item No.	Interval	Location	Procedure	Not Fully Mission Capable If:
		Item to Check/Service		
24	Weekly	Refrigeration Unit Interior	<p style="text-align: center;"><u>WARNING</u></p> <p>High voltage and exposed rotating parts are contained in the refrigeration unit. Personal injury can result if power is connected.</p> <p>a. Inspect the push switches for cracked case and loose or missing attaching hardware. If damaged or loose, notify unit maintenance to tighten or replace it as necessary.</p> <p>b. Inspect the push switches for smooth operation. If binding, notify unit maintenance to test and replace it as necessary.</p> <p>c. Inspect the push switches for frayed or broken wire leads. If damaged, notify unit maintenance to repair or replace it as necessary.</p>	The push switches stick. Wire lead frayed or broken.
		Push Switches (Side Condenser Doors)		
25	Monthly	Refrigeration Unit Exterior Condenser Top Panel	<p>a. Inspect the panel for any cracks, tears, and loose or missing hardware. If cracked, notify direct support maintenance for repair. If hardware is loose or missing, notify unit maintenance to tighten or replace it as necessary.</p> <p>b. Inspect for any chipped or missing paint and evidence of corrosion. If paint is damaged or frame shows evidence of corrosion, notify unit maintenance to paint it.</p>	

Table 2-1. Preventive Maintenance Checks and Services for Model F1000RE

Item No.	Interval	Location	Procedure	Not Fully Mission Capable If:
		Item to Check/Service		
26	Monthly	Doors	<ul style="list-style-type: none"> a. Inspect the doors for any cracks, tears, and loose or missing hardware. If cracked, notify direct support maintenance for repair. If hardware is loose or missing, notify unit maintenance to tighten or replace as necessary. b. Inspect the doors for any chipped or missing paint and evidence of corrosion. If paint is damaged or frame shows evidence of corrosion, notify unit maintenance to paint it. c. Inspect the hinges and barrel bolts for smooth operation and loose or missing attaching hardware. If hinges or barrel bolts bind, notify unit maintenance to lubricate them. If attaching hardware is loose or missing, notify unit maintenance to tighten or replace it as necessary. d. Inspect for any damaged, loose, or missing information plates and loose or missing attaching hardware. If information plates are damaged or loose, notify unit maintenance to tighten or replace them as necessary. 	The side condenser doors do not stay closed.
27	Monthly	Guards	<ul style="list-style-type: none"> a. Inspect the guards for any cracks, tears, and loose or missing hardware. If cracked, notify direct support maintenance for repair. If hardware is loose or missing, notify unit maintenance to tighten or replace as necessary. b. Inspect for chipped or missing paint and evidence of corrosion. If paint is damaged or frame shows evidence of corrosion, notify unit maintenance to paint it. 	
28	Monthly	Condenser Frame	Inspect for secure mounting to the refrigerator enclosure. If loose, notify unit maintenance to secure it.	Condenser frame is loose on refrigerator enclosure.

Table 2-1. Preventive Maintenance Checks and Services for Model F1000RE

Item No.	Interval	Location	Procedure	Not Fully Mission Capable If:
		Item to Check/Service		
		Refrigeration Unit Interior		
			<u>WARNING</u> High voltage and exposed rotating parts are contained in the refrigeration unit. Personal injury can result if power is connected.	
29	Monthly	Dehydrator	Inspect the dehydrator for damage or evidence of refrigerant leak. If damaged or evidence of leaking found, notify direct support maintenance to replace it.	Dehydrator is damaged or evidence of leak is found.
30	Monthly	Gages	Inspect the gages for evidence of refrigerant leak. If damaged or evidence of leaking found, notify direct support maintenance to replace it.	Evidence of leak is found.
31	Monthly	Receiver	Inspect the receiver for damage and evidence of refrigerant leak. Inspect the isolation valves for evidence of refrigerant leak. If damaged or evidence of leaking found, notify direct support maintenance to replace it.	Receiver is damaged or evidence of leak is found.
32	Monthly	Pressure Regulator Valves	Inspect the pressure regulator valves for damage or evidence of refrigerant leak. If damaged or evidence of leaking found, notify direct support maintenance to replace it.	Pressure regulator valve damaged or evidence of leak is found.
33	Monthly	Metal Hose Assemblies	Inspect the metal hose assemblies for kinks or evidence of refrigerant leak. If damaged or evidence of leaking found, notify direct support maintenance to replace it.	Metal hose assembly kinked or evidence of leak is found.
34	Monthly	Valves	Inspect the valves for evidence of refrigerant leak. If evidence of leaking found, notify direct support maintenance to replace it.	Evidence of leak is found.
35	Monthly	Sight Indicator	Inspect the sight indicator for evidence of refrigerant leak. If evidence of leaking found, notify direct support maintenance to replace it.	Evidence of leak is found.

Item No.	Interval	Location	Procedure	Not Fully Mission Capable If:
		Item to Check/Service		
36	Monthly	Solenoid Valves	Inspect the solenoid valves for frayed or broken wire leads, loose coil, loose or missing cover, and evidence of refrigerant leak. If coil is loose or damaged or wire leads are frayed or broken, notify unit maintenance to repair or replace it as necessary. If evidence of leaking found, notify direct support maintenance to replace it.	Wire lead frayed or broken, coil loose, or evidence of leak is found.
37	Monthly	Flare Couplings	Inspect the flare couplings for evidence of refrigerant leak. If evidence of leaking found, notify direct support maintenance to tighten or replace them as necessary.	Evidence of leak is found.
38	Monthly	Accumulator	Inspect the accumulator for damage and evidence of refrigerant leak. If damaged or evidence of leaking found, notify direct support maintenance to replace it.	Accumulator is damaged or evidence of leak is found.
39	Monthly	Tubing and Fittings.	Inspect the tubing and fittings for kinks, restriction (crushed), or evidence of refrigerant leak. If damaged or evidence of leaking found, notify direct support maintenance to repair or replace it as necessary.	Tubing or fittings damaged, kinked, or evidence of leak is found.
40	Monthly	Pressure Switches	Inspect the pressure switches for frayed or broken wire leads and dented, loose, or missing cover. Inspect for evidence of refrigerant leak. If cover is loose or wire leads are frayed or broken, notify unit maintenance to repair or replace it as necessary. If damaged or evidence of leaking found, notify direct support maintenance to replace it.	Wire lead frayed or broken, cover missing, or evidence of leak is found.

Table 2-1. Preventive Maintenance Checks and Services for Model F1000RE

Item No.	Interval	Location	Procedure	Not Fully Mission Capable If:
		Item to Check/Service		
41	Monthly	Compressor	Inspect the compressor for frayed or broken wire leads and loose or missing terminal cover. Inspect the sight glass for cracks. Inspect for evidence of refrigerant leak. Inspect shut off valves for evidence of refrigerant leak. If wire leads are frayed or broken, notify unit maintenance to repair or replace it as necessary. If damaged or evidence of leaking found, notify direct support maintenance to repair or replace it as necessary.	Wire lead frayed or broken, cover missing, sight glass cracked or evidence of leak is found.
42	Monthly	Strainer	Inspect the strainer for dents or evidence of refrigerant leak. If damaged or evidence of leaking found, notify direct support maintenance to replace it.	Strainer is dented or evidence of leak is found.

SECTION III OPERATION UNDER USUAL CONDITIONS**2-4. ASSEMBLY AND PREPARATION FOR USE.**

The refrigeration unit requires specialized unpacking, installation, and power connection procedures. Notify unit maintenance for installation.

2-5. STARTUP PROCEDURES.

(See fig. 2-4.)

CAUTION

Operating the refrigeration unit with the service valves improperly set will damage the equipment. Do not operate unless you are sure it has been properly set up for operation. Notify unit maintenance.

- a. Be sure the refrigeration unit is connected to an active source of 208/230 VAC, 3 phase, 50/60 Hz electric power.

NOTE

Push switches in the side condenser door frames will prevent the refrigeration unit from operating if the side doors are open.

- b. Be sure both side condenser doors (1) are closed and secured.
- c. Set the remote bulb thermostat (TEMPERATURE CONTROL) (2) to the desired refrigerator enclosure temperature.
- d. Place the circuit breaker handle (3) in the ON position.
- e. Place the toggle switch (START/RUN, OFF) (4) handle in the START/RUN position.

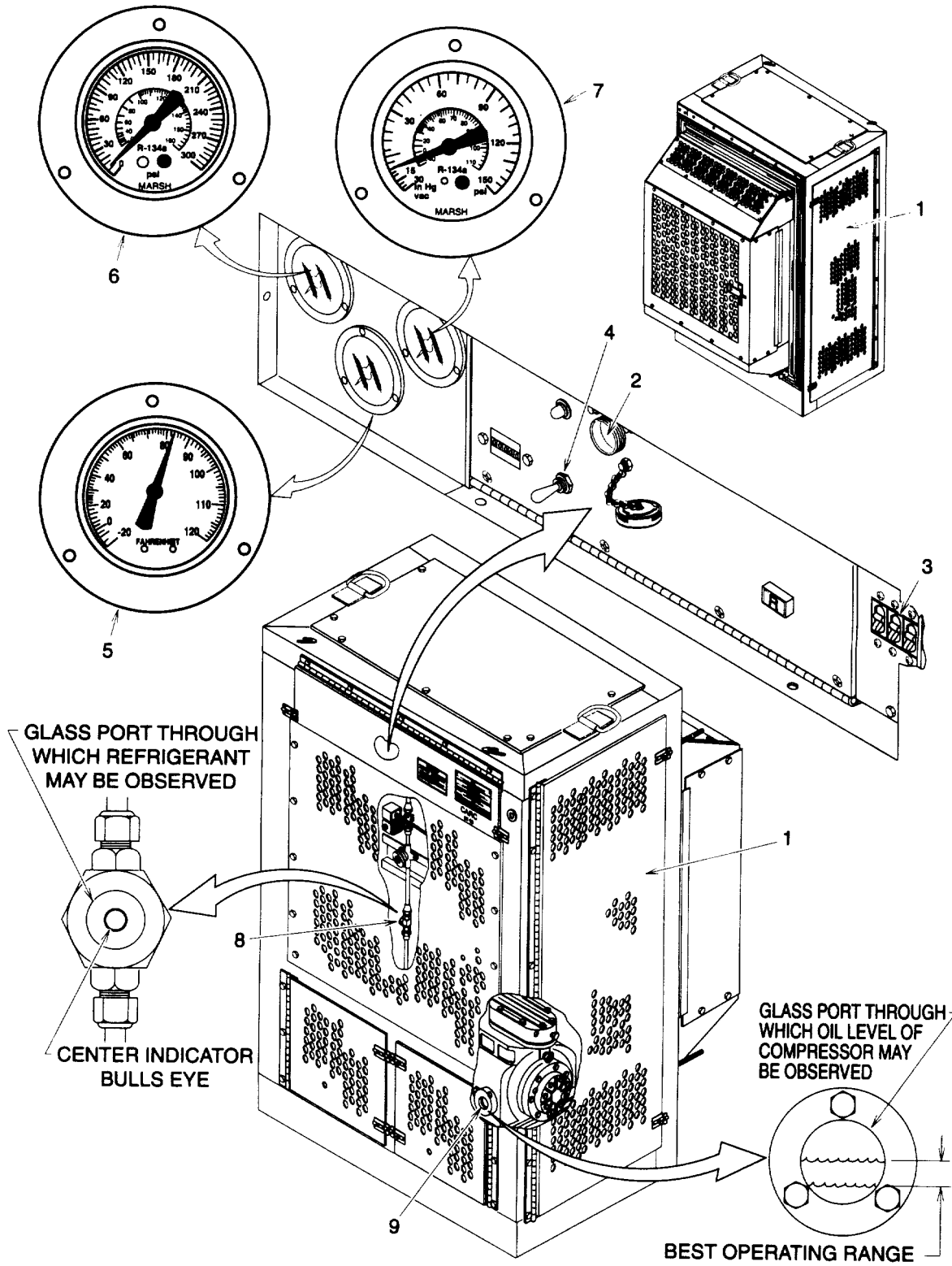


Figure 2-4. Operator Controls and Indicators

2-6. OPERATOR CHECKS.

(See fig. 2-4.)

NOTE

All checks must be performed when the DEFROST IN PROGRESS indicator is off.

- a. Check the thermometer (REFRIGERATION TEMPERATURE) (5) periodically to be sure it is within 15° F (7° C) of the temperature set on the remote bulb thermostat (TEMPERATURE CONTROL) (2).
- b. Check the pressure gage (DISCHARGE PRESSURE) (6) periodically to be sure it is between 165 and 250 psi (1138.5 and 1725 kPa).
- c. Check the compound gage (SUCTION PRESSURE) (7) periodically to be sure it is between 0 and 15 psi (0 and 103.5 kPa).

NOTE

An occasional flash of bubbles in the sight indicator (SIGHT GLASS) port is normal. The sight indicator can be viewed looking through the side condenser door.

- d. Check the sight indicator (SIGHT GLASS) (8) port to be sure it is clear. The center indicator should be green or chartreuse in color.

NOTE

Occasional bubbles in the compressor sight glass oil is normal. The sight glass can be viewed looking through the front bottom panel.

- e. Check the compressor sight glass (9) port to be sure the oil is clear and the level is between 1/4 and 1/2 up the port.

2-7. SHUTDOWN PROCEDURES.

(See fig. 2-4.)

NOTE

If the refrigeration unit is to be left off for several days, it must be pumped down. Notify Unit Maintenance.

- a. Place the toggle switch (START/RUN, OFF) (4) handle in the OFF position.
- b. When the refrigeration unit stops running, place the circuit breaker handle (3) in the OFF position.
- c. Notify unit maintenance if the refrigeration unit is to be put into administrative storage for several days.

2-8. DECALS AND INSTRUCTION PLATES.

Decals and instruction plates are illustrated in the following figure.

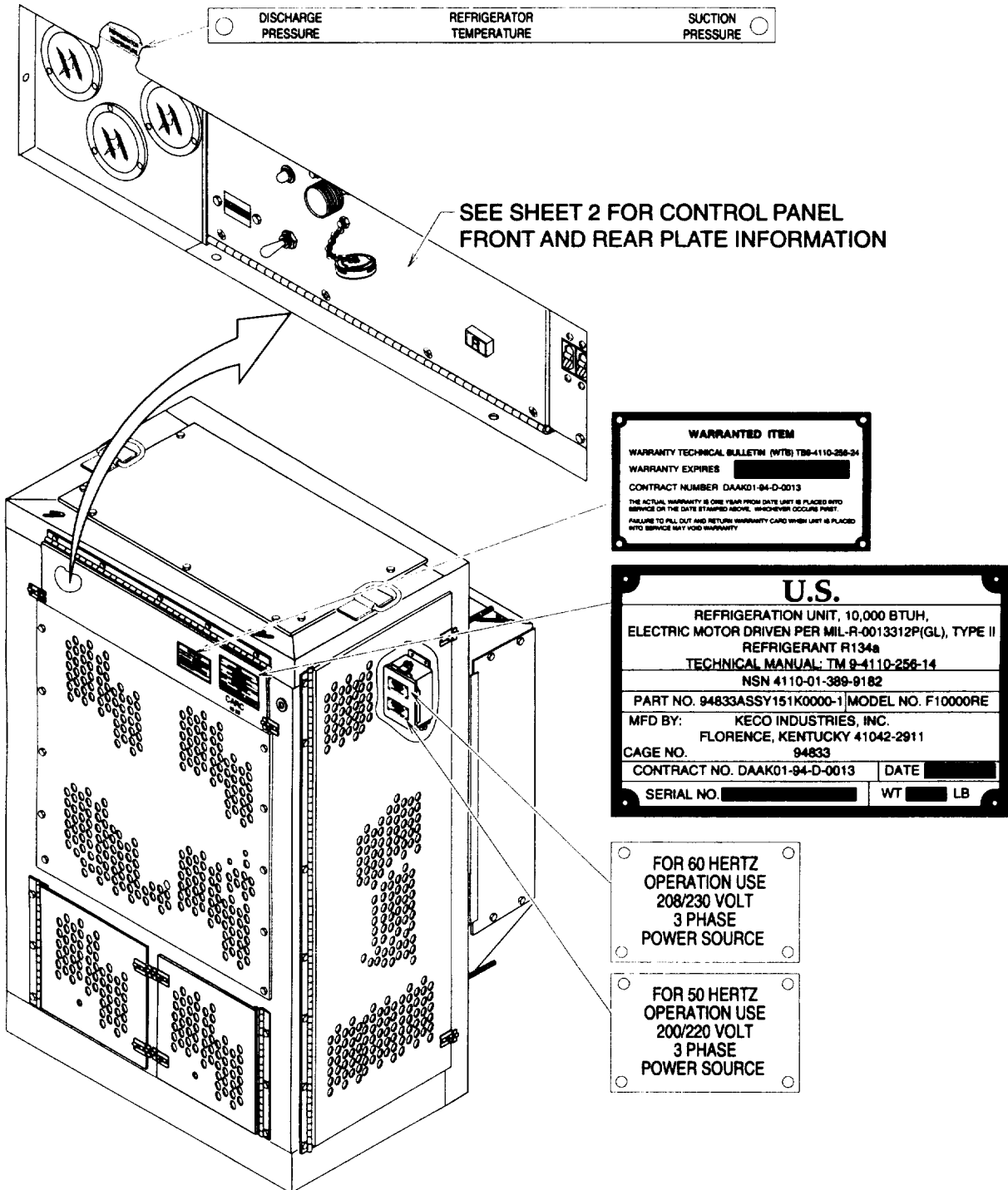
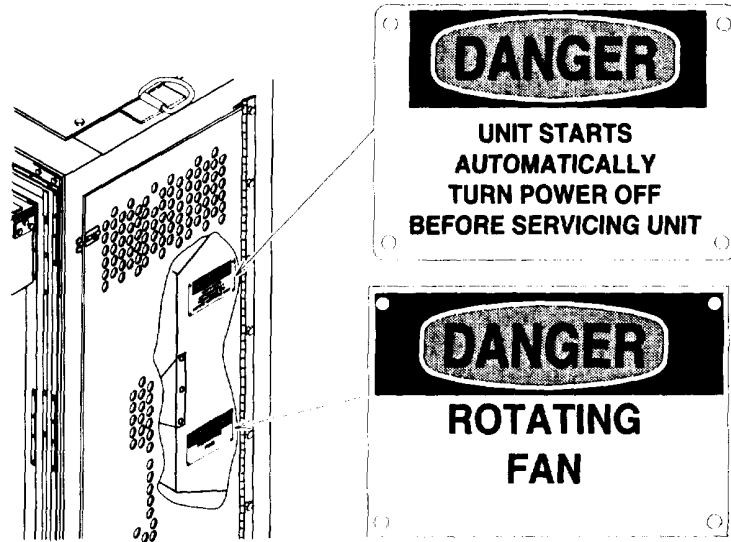
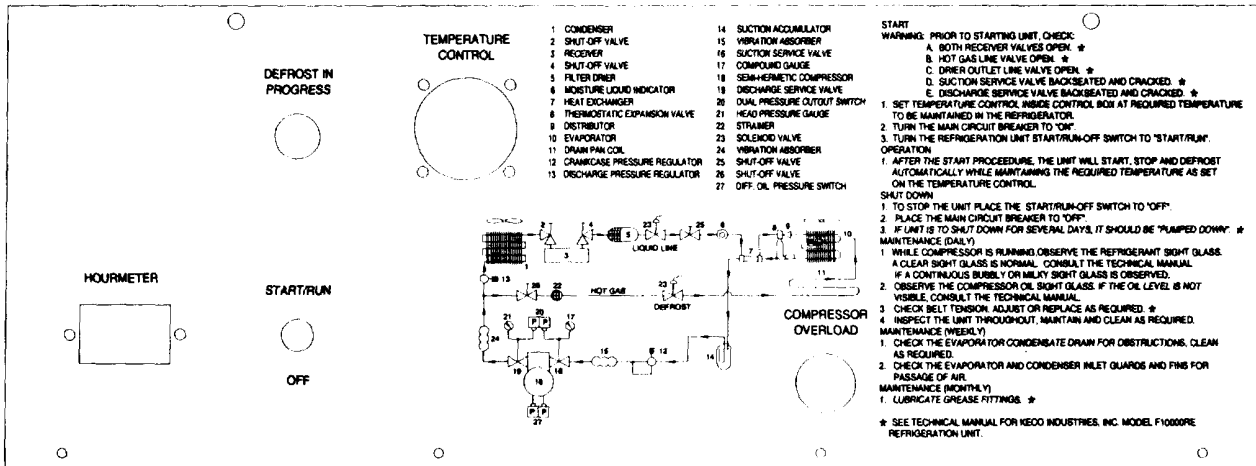


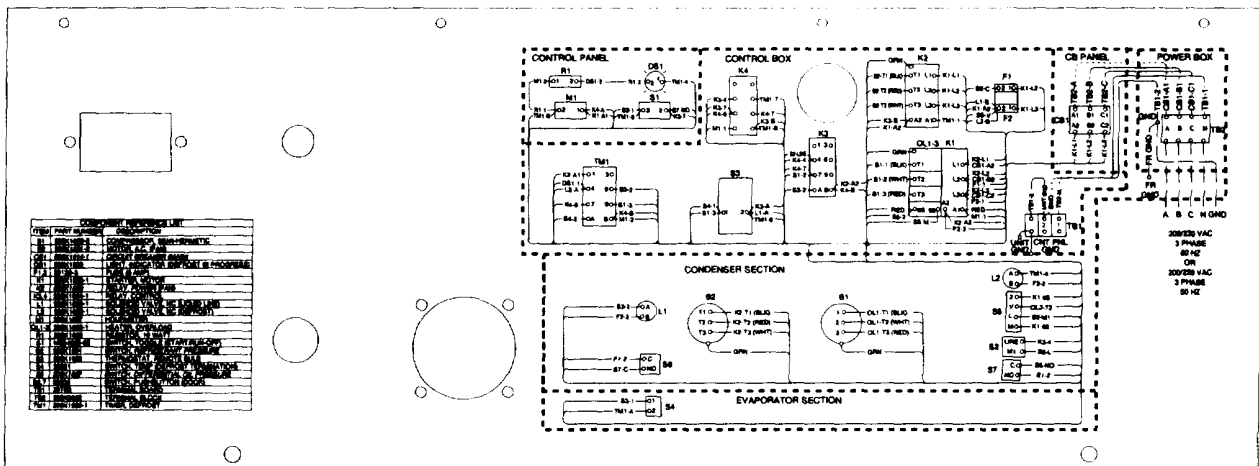
Figure 2-5. Decals and Instruction Plates (Sheet 1 of 2)



THE ABOVE TWO PLATES ARE INSTALLED ON BOTH SIDES OF FAN SHROUD



CONTROL PANEL FRONT



CONTROL PANEL REAR

Figure 2-5. Decals and Instruction Plates (Sheet 2 of 2)

SECTION IV OPERATION UNDER UNUSUAL CONDITIONS**2-9. OPERATION UNDER INCLEMENT WEATHER.**

The refrigeration unit is designed to operate under adverse conditions and does not require additional precautions or procedures.

2-10. NBC DECONTAMINATION PROCEDURES.

The following emergency procedures can be performed until field NBC decon facilities are available. If NBC attack is known or suspected, mask at once and continue mission. If outside, follow decon procedures below to avoid taking contamination into controlled area. Do not unmask until told to do so.

NOTE

Detailed decontamination procedures can be found in: FM 3-3, FM 3-4, and FM 3-5.

- a. Nuclear Decontamination. Brush fallout from skin, clothing and equipment with available brushes, rags, and tree branches. Wash skin and have radiation check made when tactical situation permits.
- b. Biological Decontamination. Remain masked and continue mission until told to unmask.
- c. Chemical Detection and Decontamination.

WARNING

Some decontamination sprays can cause personal injury and should not be used on personnel.

- (1) Contact your local chemical detachment or unit for proper use of decontamination equipment.
- (2) If exposure to liquid agent is known or suspected, clean exposed skin, clothing, personal gear, and equipment, in that order, using M258A1 kit. Use the buddy system. Wash exposed skin and thoroughly decontaminate when tactical situation permits.
- (3) Use M8 paper from the M256 Chemical Agent Detector Kit or M9 paper to determine if liquid agent is present on the equipment.
- (4) If the M8 or M9 paper indicates that liquid chemical agent is present on the equipment, use the NBC-M11 decon apparatus to decon equipment.

CHAPTER 3

OPERATOR MAINTENANCE INSTRUCTIONS

		Page
SECTION I	LUBRICATION	3-1
	3-1 Lubrication	3-1
SECTION II	TROUBLESHOOTING PROCEDURES.....	3-2
	3-2 Trouble shooting.....	3-2
SECTION III	OPERATOR'S MAINTENANCE INSTRUCTIONS	3-5
	3-3 General	3-5
	3-4 Cleaning.....	3-5

SECTION I LUBRICATION

3-1. LUBRICATION.

Operator lubrication not required.

SECTION II TROUBLESHOOTING PROCEDURES

3-2. TROUBLESHOOTING.

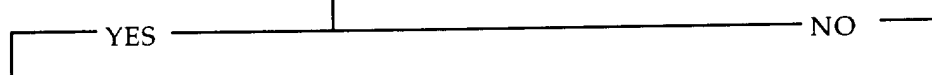
The following procedures are listed in order of the most probable malfunctions. Each malfunction is followed by test or inspection procedures in logical order to isolate and identify the fault and actions required to correct it. This section cannot list all the possible malfunctions that may occur with the equipment. If a malfunction occurs that is not listed or actions listed do not correct a malfunction, notify your supervisor.

MALFUNCTION INDEX

	Troubleshooting Procedure Para
Refrigeration unit does not start.....	3-2, a.
Thermometer (REFRIGERATOR TEMPERATURE) indicates more than 15°F above remote bulb thermostat (TEMPERATURE CONTROL) setting.....	3-2, b.
Pressure Gage (DISCHARGE PRESSURE) indicates above 250 psi (1725 kPa)	3-2, c.
Pressure Gage (DISCHARGE PRESSURE) indicates below 165 psi (1138.5 kPa)	3-2, d.
Compound Gage (SUCTION PRESSURE) indicates above 15 psi (103.5 kPa)	3-2, e.
Compound Gage (SUCTION PRESSURE) indicates below 0 psi (0 kPa).....	3-2, f.

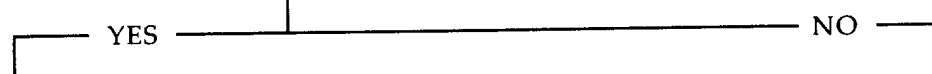
a. Refrigeration Unit Does Not Start.

IS POWER SOURCE CONNECTED AND ACTIVE?



PLACE CIRCUIT BREAKER IN ON POSITION, TOGGLE SWITCH (START/RUN, OFF) IN START/RUN POSITION, AND PRESS RESET BUTTON (COMPRESSOR OVERLOAD). DOES REFRIGERATION UNIT START?

ACTIVATE POWER SOURCE OR NOTIFY UNIT MAINTENANCE TO CONNECT REFRIGERATION UNIT TO POWER SOURCE.



CONTINUE WITH NORMAL OPERATION. IF CIRCUIT BREAKER OR RESET BUTTON (COMPRESSOR OVERLOAD) TRIP AGAIN, NOTIFY UNIT MAINTENANCE TO TEST OR REPLACE IT AS NECESSARY.

ARE CONDENSER SIDE DOORS CLOSED?

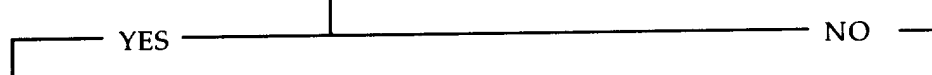


OPEN RIGHT CONDENSER SIDE DOOR. PRESS THE DIFFERENTIAL OIL PRESSURE SWITCH AND DUAL PRESSURE CONTROL SWITCH RESET BUTTONS. CLOSE CONDENSER SIDE DOOR. IF DIFFERENTIAL OIL PRESSURE OR DUAL PRESSURE CONTROL SWITCH TRIPS AGAIN, NOTIFY DIRECT SUPPORT MAINTENANCE. IF REFRIGERATION UNIT DOES NOT START, NOTIFY UNIT MAINTENANCE.

CLOSE CONDENSER SIDE DOORS.

b. Thermometer (REFRIGERATOR TEMPERATURE) Indicates More Than 15° F (7° C) Above Remote Bulb Thermostat (TEMPERATURE CONTROL) Setting

IS THE REFRIGERATION UNIT RUNNING?

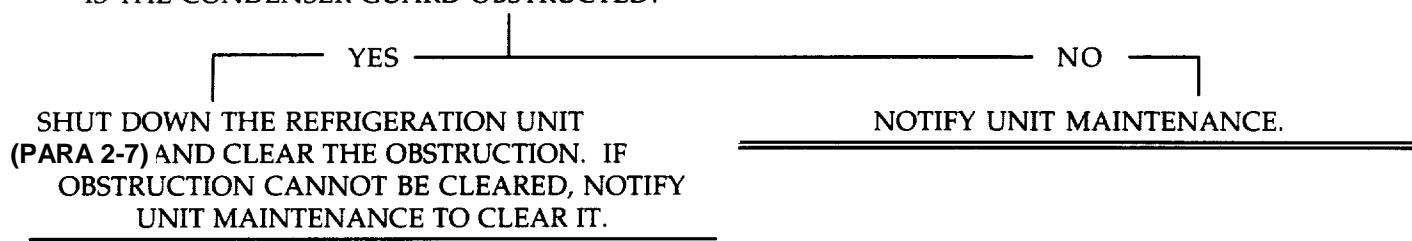


CHECK READINGS ON PRESSURE AND COMPOUND GAGES. IF READINGS ARE ABOVE OR BELOW NORMAL OPERATING RANGE, SEE APPROPRIATE TROUBLE SHOOTING PROCEDURE. IF THE INDICATED TEMPERATURE IS STILL NOT WITHIN RANGE, NOTIFY UNIT MAINTENANCE.

START REFRIGERATION UNIT (PARA 2-5).

- c. Pressure Gage (DISCHARGE PRESSURE) Indicates Above 250 psi (1725 kPa). At start up and / or operation in high ambient temperatures, pressures above 250 psi (1725 kPa) are possible.

IS THE CONDENSER GUARD OBSTRUCTED?

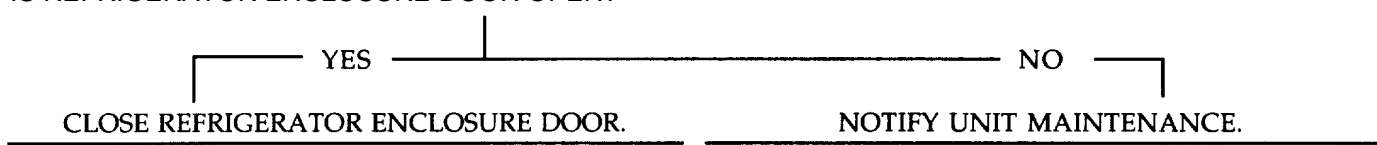


- d. Pressure Gage (DISCHARGE PRESSURE) Indicates Below 165 psi (1138.5 kPa). During operation in low ambient temperatures, pressures above 165 psi (103.5 kPa) are possible.

NOTIFY UNIT MAINTENANCE

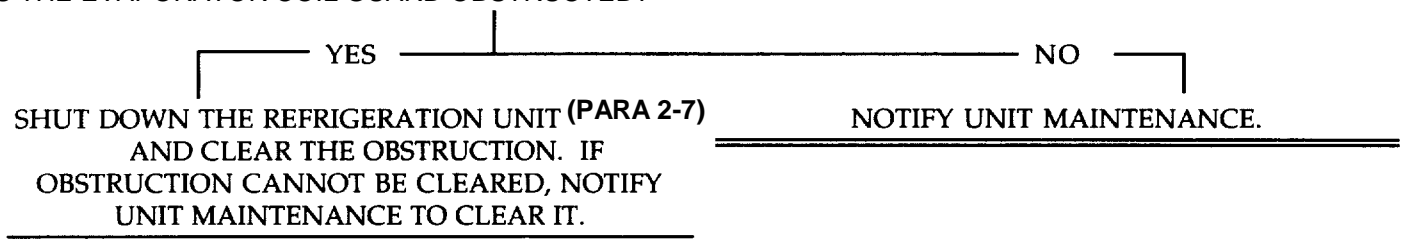
- e. Compound Gage (SUCTION PRESSURE) Indicates Above 15 psi (103.5 kPa). At start up and / or operation in high ambient temperatures, pressures above 15 psi (103.5 kPa) are possible.

IS REFRIGERATOR ENCLOSURE DOOR OPEN?



- f. Compound Gage (SUCTION PRESSURE). Indicates Below 0 psi (0 kPa). At start up, shut down, or operation in low ambient temperatures, pressures below 0 psi (0 kPa) are possible

IS THE EVAPORATOR COIL GUARD OBSTRUCTED?



SECTION III OPERATOR'S MAINTENANCE PROCEDURES

INDEX

Para

ENCLOSURE

General3-3

Cleaning.....3-4

3-3. GENERAL.

With the exception of service and inspection procedures noted in the PMCS table 2-1, the following maintenance procedure is the only one authorized to the operator.

3-4. CLEANING.

This task covers: Cleaning

INITIAL SETUP

Equipment Conditions:

Reference
 Para 2-7 Refrigeration unit shut down.
 Doors open as necessary.

General Safety Instructions:

WARNING

High voltage and exposed rotating parts are contained in the refrigeration unit. Personal injury can result if power is connected.

Materials/ Parts:

Detergent
 6, Appendix E
 Rag
 2, Appendix E

Cleaning.

- (1) Mix a small quantity of detergent with clean water to make a wash solution.
- (2) Dampen a rag with wash solution and clean the equipment.
- (3) Dampen a rag with clean water and rinse the equipment. Rinse rag in clean water and continue until all detergent residue has been removed.
- (4) Wipe the equipment with a clean dry rag until thoroughly dry.

CHAPTER 4**UNIT MAINTENANCE INSTRUCTIONS****SECTION I REPAIR PARTS, TOOLS, SPECIAL TOOLS, TEST, MEASUREMENT, AND DIAGNOSTIC EQUIPMENT (TMDE), AND SUPPORT EQUIPMENT****4-1. COMMON TOOLS AND EQUIPMENT.**

- a. For authorized common tools and equipment, refer to the Modified Table of Organization and Equipment (MTOE), CTA 50-970, or CTA 8-100, as applicable to your unit.
- b. The Refrigeration Unit Service Tool Kit (SC 5180-90-CL-N18) will be used for all maintenance tasks. Any additional tools required for an individual maintenance task will be identified in the setup information for that task.

4-2. SPECIAL TOOL, TMDE, AND SUPPORT EQUIPMENT.

- a. The Repair Parts and Special Tools List (RPSTL) (TM 9-4110-256-24P) as well as the Maintenance Allocation Chart (MAC) (appendix B) identify any tools and support equipment needed to maintain the refrigeration unit.
- b. There are no special or fabricated tools required to maintain the refrigeration unit.

4-3. REPAIR PARTS.

- a. Any mandatory replacement parts needed for the maintenance tasks are identified in the mandatory replacement parts list located in Appendix G.
- b. Repair parts are listed and illustrated in the repair parts and special tools list (TM 9-4110-256-24P) covering unit maintenance for this equipment.

SECTION II SERVICE UPON RECEIPT**4-4. SITE AND SHELTER REQUIREMENTS.**

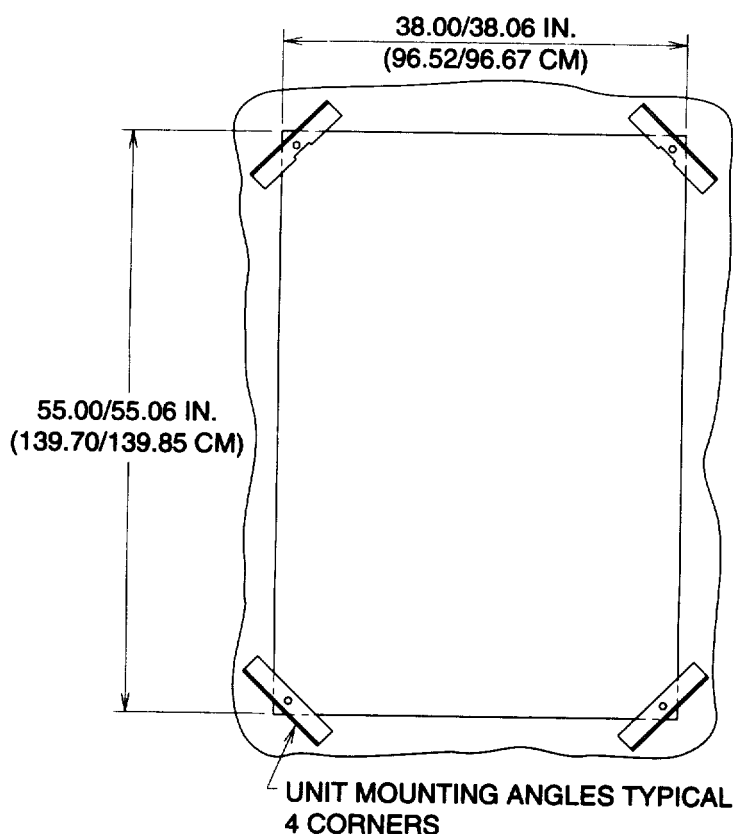
- a. The refrigeration unit requires a source of 208/230 Vac, 50/60 Hz, 18 amp electric power connected directly to the input power enclosure assembly.
- b. The refrigerator enclosure must have an accessible wall area 4 feet wide and 5 feet high to accommodate the refrigeration unit and mounting angles.
- c. The refrigeration unit weighs 1000 lb (454 Kg). The refrigerator enclosure wall must be strong enough to support this weight.

4-5. SERVICE UPON RECEIPT OF MATERIAL.

- a. Inspect the equipment for damage incurred during shipment. If the equipment has been damaged, report the damage on SF 364, Report of Discrepancy.
- b. Check the equipment against the packing slip to see if the shipment is complete. Report all discrepancies in accordance with the instructions of DA Pam 738-750.

4-6. INSTALLATION INSTRUCTIONS.

- a. Tools and Equipment. Tools required to install the refrigeration unit include a wrench for tightening the mounting angles, lifting sling(s), spreader-bar (if needed), and hoist or similar lifting device.
- b. Refrigerator Enclosure Preparation. The refrigerator enclosure must have an opening 38.00/38.06 inches (96.52/96.67 cm) wide and 55.00/55.06 inches (139.70/139.85 cm) high (fig. 4-1) to insert the refrigeration unit. If an opening does not already exist in the enclosure, see the enclosure manual for information on making such an opening.

**Figure 4-1. Wall Opening Dimensions****c. Installation.**

- (1) Remove four nuts (1, fig. 4-2), lock washers (2), and unit mounting angles (3) if attached to the refrigeration unit. If the mounting hardware is not attached, locate it now.

- (2) Attach the sling(s) (4) to the lifting rings (5).

CAUTION

Failure to use a spreader bar or two point lifting device, such as a fork lift, can cause damage to the condenser frame when lifted.

- (3) If a single point lifting device is being used, install the spreader bar onto the sling(s) (4) at approximate mid-way point.

WARNING

The refrigeration unit can swing and move when lifted. Personal injury can result if standing near unit when it is lifted.

- (4) Connect a hoist or similar lifting device to the sling(s) (4) and lift the refrigeration unit.
- (5) Carefully position the refrigeration unit into the refrigerator enclosure opening.

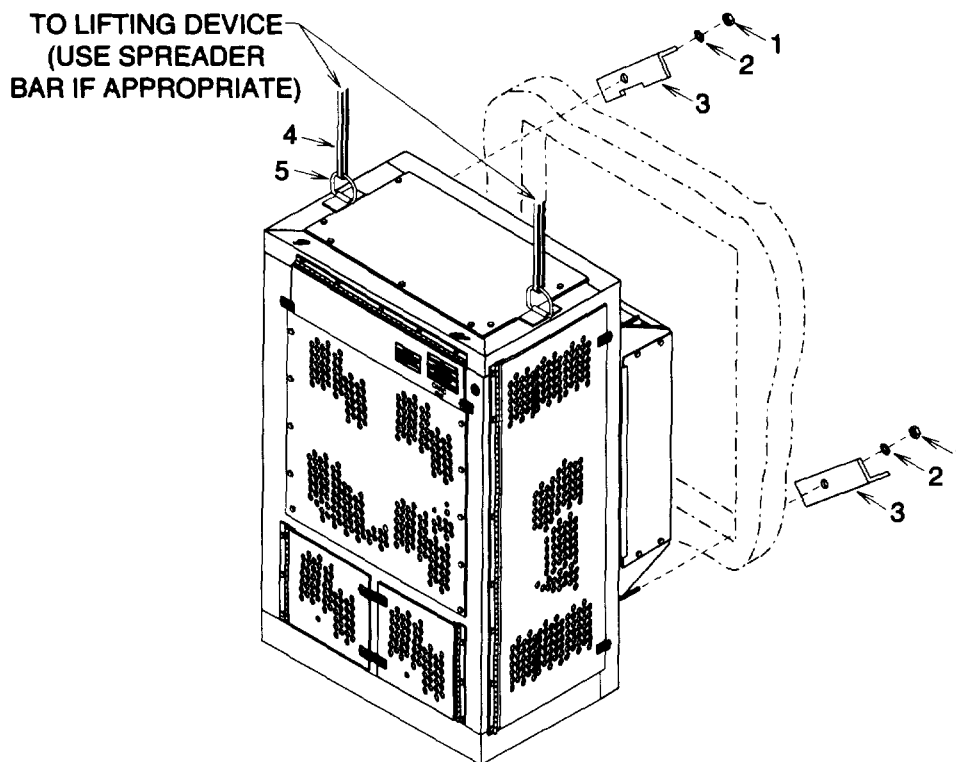


Figure 4-2. Installation

4-6. INSTALLATION INSTRUCTIONS. -Continued**NOTE**

The two mounting angles with notches must go on top.

- (6) Secure the refrigeration unit to the refrigerator enclosure using four unit mounting angles (3), lock washers (2), and nuts (1).
 - (7) Remove sling(s) (4).
- d. Power Connection. The refrigeration unit must be connected to a four or five wire 208/230 Vac, 50/60 Hz, 1 amp source of electrical power.
- (1) Open right side condenser door (1, fig. 4-3).
 - (2) Loosen two screws (2) and open enclosure assembly door.

WARNING

High voltage can kill. Personal injury or death can occur if power is connected to input power cable when installing.

- (3) Be sure power is disconnected from input power cable. Push cable through rubber grommet (3) then through cable strain relief bushing (4). Leave enough slack in cable wire leads to make connections to terminals and tighten bushing.

CAUTION

Operating the refrigeration unit prior to performing preliminary service, can cause equipment damage.

- (4) Connect wire leads to terminal block TB2 and GROUND inside enclosure assembly. When using only four wires, connect the fourth wire to GROUND and not neutral (N).

WARNING

High voltage will be exposed in enclosure assembly. Connecting power to the refrigeration unit with the enclosure assembly door open can cause personal injury or death.

- (5) Close enclosure assembly door and tighten two screws (2) to secure.
- (6) Close and secure right side condenser door (1).

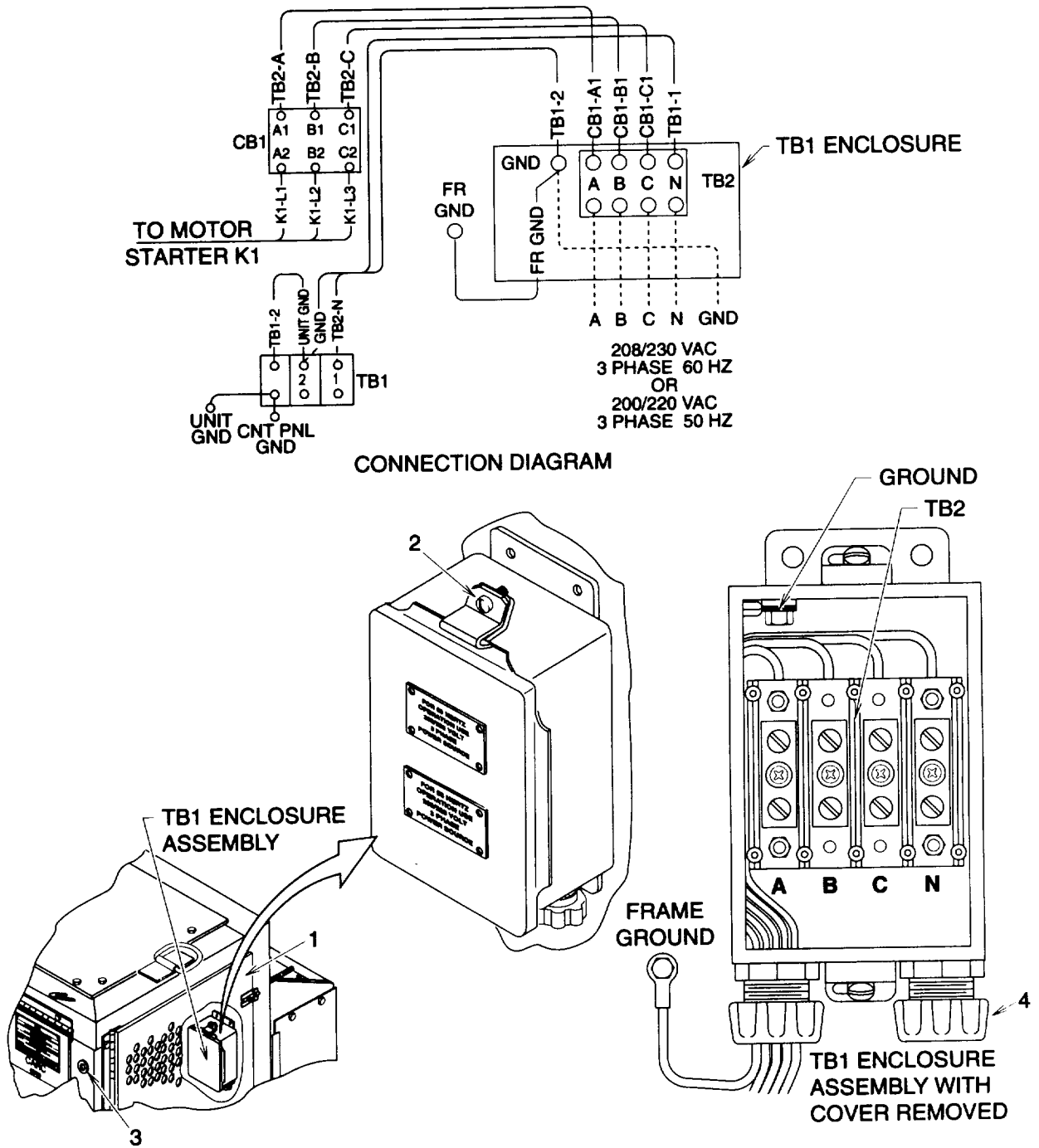


Figure 4-3. Input Power Connection

WARNING

Exposed rotating parts are contained in the refrigeration unit. Personal injury can result if doors are not closed.

4-7. PRELIMINARY SERVICING OF EQUIPMENT.

- a. Open both side condenser doors and both front bottom doors.

CAUTION

Using excessive force when opening or closing valves can cause damage to the valve seats.

- b. Fully open both stop valves (1, fig. 4-4) and (2).

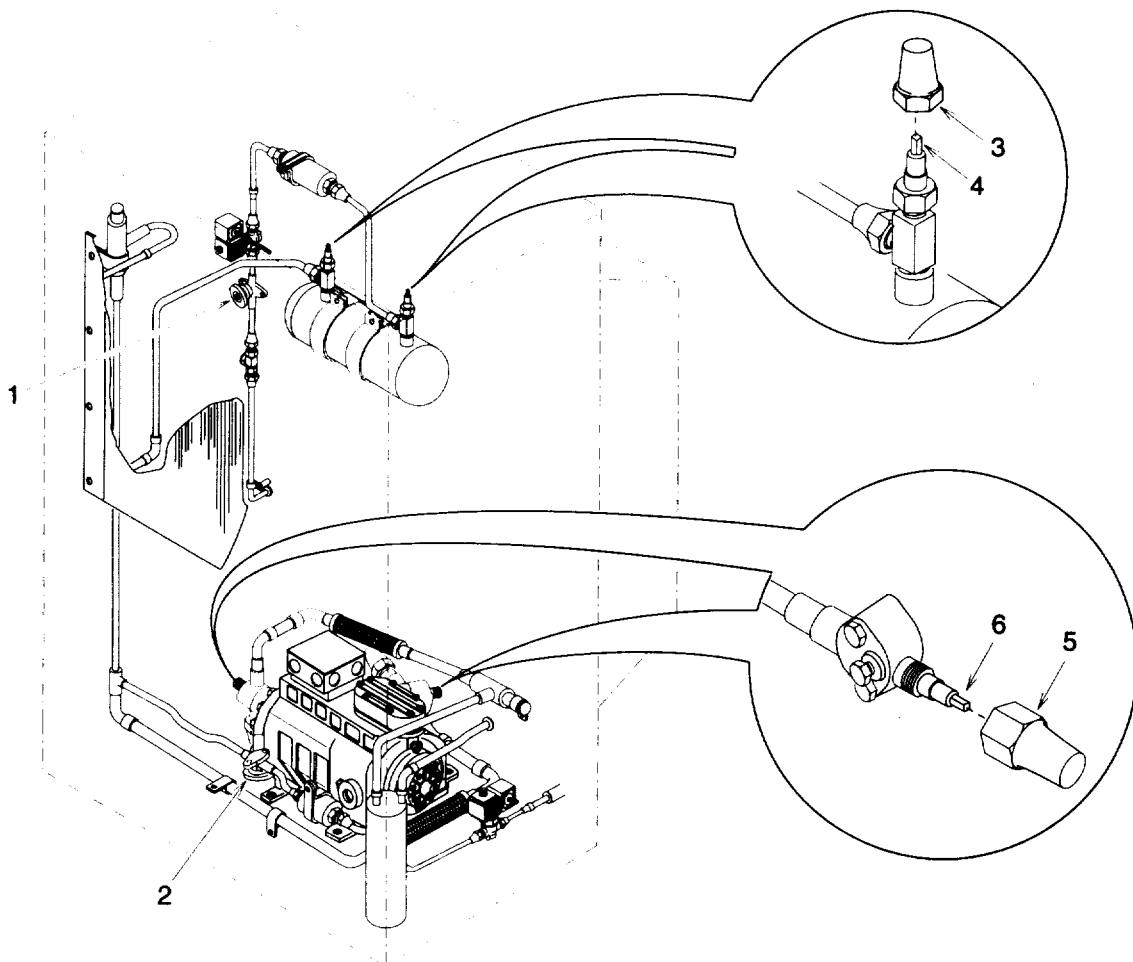


Figure 4-4. Refrigeration Valve Settings for Normal Operation

- c. Remove two caps (3) and fully open two isolation valves (4). Install two caps.

NOTE

The compressor shut off valves can be adjusted to three positions, fully closed to block the refrigerant tubes and isolate the compressor and service port, fully open to allow flow from piping to compressor but not the service port, and cracked (one turn closed from fully open) to allow flow from piping to compressor and service port on valve.

- d. Remove two caps (5) and fully open two shut off valves (6). Install two caps.
- e. Loosen four compressor mount locknuts (1, fig. 4-5). Loosen screw (2) until proper operating space (1.5 in. (3.81 cm)) is reached. Shipping bracket (3) must remain clipped to spring (4).

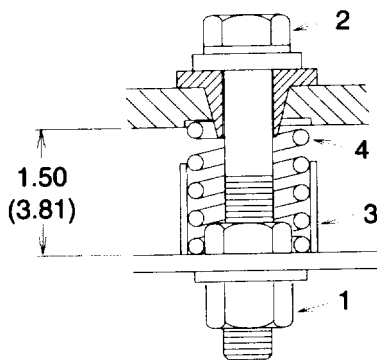


Figure 4-5. Compressor Mount

- f. Close both side condenser doors and both front bottom doors.

4-8. PRELIMINARY ADJUSTMENT OF EQUIPMENT.

- a. Open control panel cover and secure open with door holder clips.
- b. Remove two bolts (1, fig. 4-6) and lock washers (2). Open the control box cover (3). Discard lock washers.

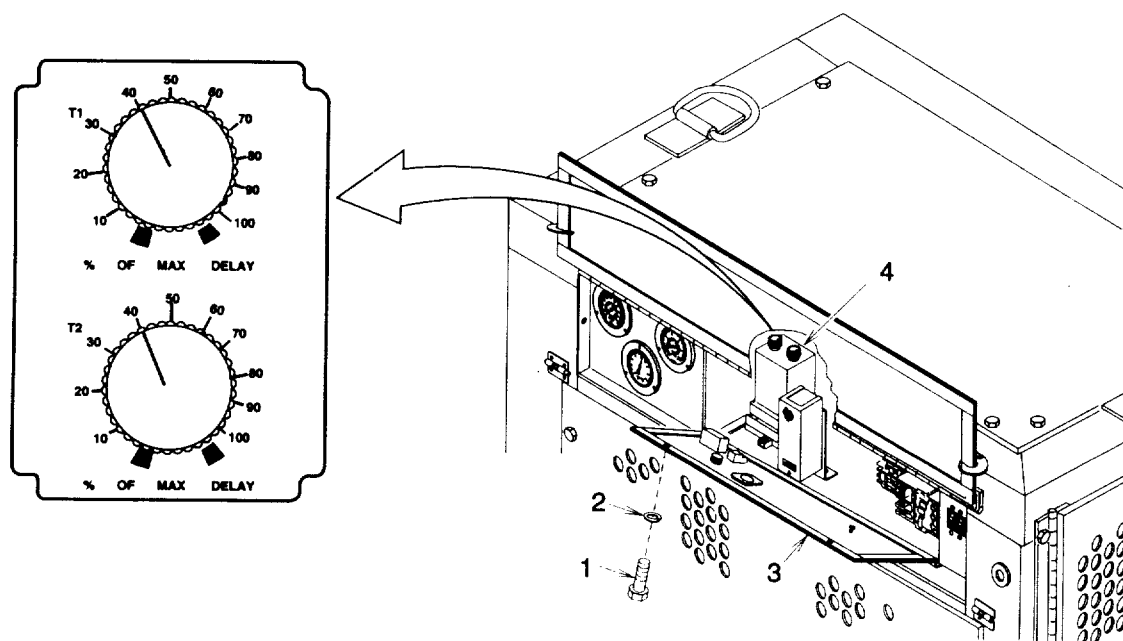
4-8. PRELIMINARY ADJUSTMENT OF EQUIPMENT. - Continued

Figure 4-6. Repeat Cycle Timer Adjustment

NOTE

- The repeat cycle timer controls are marked T1 and T2. Control T1 adjusts the length of time the refrigeration unit will operate continuously before initiating a defrost cycle. Control T2 adjusts the maximum length of time the refrigeration unit will remain in the defrost cycle.
 - The timer scales indicate an approximate percentage of time based on 24 hours. For example, to set the timer for 6 hours, adjust the control to 25% (6 hours is 25% of 24 hours).
 - The timer controls have a minimum setting of 14 minutes when set at 0%.
- c. Adjust the repeat cycle timer (4) control T1 to approximately 25% (6 hours) and control T2 to approximately 2% (30 minutes). This is the recommended factory setting, however, the controls can be set as desired to best suit the operating conditions.
 - d. Close the control box cover (3). Install two bolts (1) with new lock washers (2) (item 1, appendix G).
 - e. Close and secure the control panel cover.

SECTION III UNIT PREVENTIVE MAINTENANCE CHECKS AND SERVICES (PMCS)

4-9. LUBRICATION.

The lubrication instructions and hardtime intervals contained in Figure 4-7 are mandatory. This refrigeration unit is not enrolled in the Army Oil Analysis Program. HARDTIME INTERVALS APPLY.

4-10. GENERAL.

Preventive Maintenance Checks and Services (PMCS) are essential to the efficient operation of the refrigeration unit and to prevent possible damage that might occur through neglect or failure to observe warning symptoms in a timely manner. Intervals are determined by hours in operation expressed in applicable units of measure. The Preventive Maintenance Checks and Services Table 4-1 lists procedures done first or most frequently.

a. Warnings and Cautions. Always observe the warnings and cautions appearing in your PMCS Table. Warnings and cautions appear before applicable procedures. You must observe these warnings and cautions to prevent serious injury to yourself and others or prevent your equipment from being damaged.

b. Explanation of Table Entries.

(1) Item Number Column. Numbers in this column are for reference. When completing DA Form 2404 (Equipment Inspection and Maintenance Worksheet), include the item number for the check/service indicating a fault. Item numbers also appear in the order that you must do checks and services for the intervals listed.

(2) Interval Column. This column tells you when you must do the procedure in the procedure column. BEFORE procedures must be done before you operate or use the equipment for its intended mission. DURING procedures must be done during the time you are operating or using the equipment for its intended mission. AFTER procedures must be done immediately after you have operated or used the equipment. When a check and service procedure is required for both WEEKLY and BEFORE intervals, it is not necessary to do the procedure twice if the equipment is operating during the WEEKLY period.

(3) Location Check/Service Column. This column provides the location and the item to be checked or serviced. The item location is underlined.

(4) Procedure Column. This column gives the procedure you must do to check or service the item listed in the Check/Service column to know if the equipment is ready or available for its intended mission or for operation. You must do the procedure at the time stated in the, interval column.

(5) Not Fully Mission Capable If: Column. Information in this column tells you what faults will keep your equipment from being capable of performing its primary mission. If you made a check and service procedure that shows faults listed in this column, do not operate the equipment. Follow standard operating procedures for maintaining the equipment or reporting equipment failure.

4-10. GENERAL - Continued

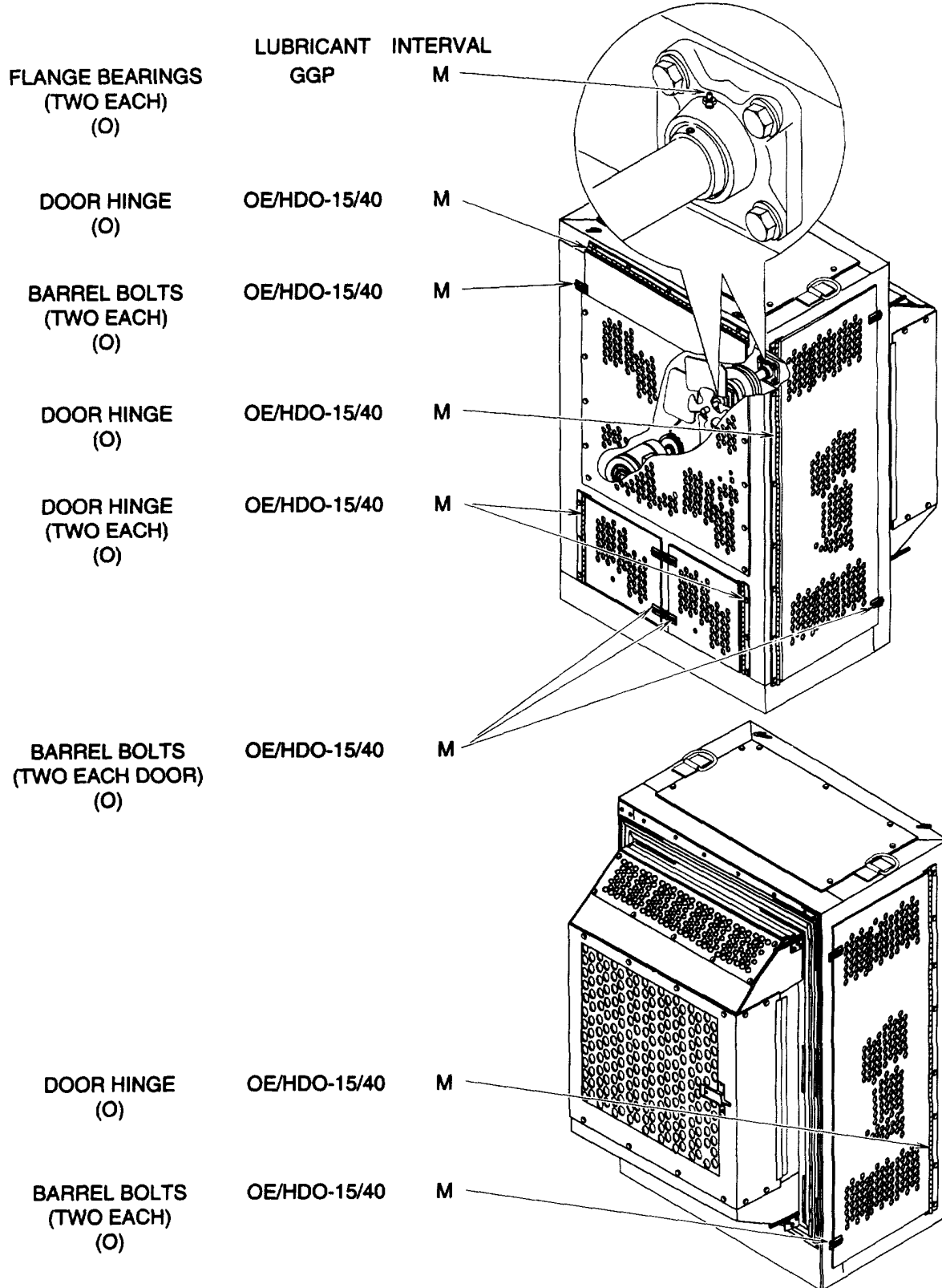


Figure 4-7. Lubrication

c. Special Information Paragraphs.

(1) Corrosion Prevention Control. If a corrosion problem is identified, it can be reported using Standard Form 368, Production Quality Deficiency Report. The form should be submitted to the address specified in DA Pam 738-750. This will result in more definitive actions be taken to prevent future occurrences.

(2) Leakage Definition for Unit PMCS. It is necessary for you to know how fluid leakage affects the status of your refrigeration unit. Oil is carried with the refrigerant as it flows through the refrigeration system. If a leak develops in the system, the oil will seep out and soak the copper tubing around the leak or drip and soak or puddle on the frame or other component below the leak. If any oil or seepage is found, a refrigerant leak would be suspected.

(a) Class I is defined as seepage of fluid (as indicated by wetness or discoloration) but not great enough to form drops.

(b) Class II is defined as leakage of fluid great enough to form drops but not enough to cause drops to drip from item being checked/inspected.

(c) Class III is defined as leakage of fluid great enough to form drops that fall from item being checked/inspected.

INITIAL SETUP

Tools:

- Fin Comb
3, Section III, Appendix B
- Grease Gun
1, Section III, Appendix B
- Scrub Brush
1, Section III, Appendix B

Personnel Required:

2

Materials/Parts:

- Wiping Rag
3, Appendix E
- Detergent
4, Appendix E
- General Purpose Lubricating Oil
5, Appendix E
- Multipurpose Grease
6, Appendix E

General Safety Instructions:

WARNING

High voltage and exposed rotating parts are contained in the refrigeration unit. Personal injury can result if power is connected.

Table 4-1. Preventive Maintenance Checks and Services for Model F1000RE

NOTE

If the equipment must be kept in continuous operation, do only the procedures that can be done without disturbing operation. Make complete checks and services when the equipment is shut down.

Item No.	Interval	Location	Procedure	Not Fully Mission Capable If:
		Item to Check/Service		
1	Monthly	Refrigeration Unit Exterior	Service the doors by lubricating the hinges (fig. 4-7). a. Apply lubricating oil (MIL-L-2104) sparingly from oil can onto the hinge moving joint surfaces. b. Wipe away excess lubricating oil with a clean rag.	
		Doors		
2	Monthly	Barrel Bolts	Service the barrel bolts by lubricating them (fig. 4-7). a. Apply lubricating oil (MIL-L-2104) sparingly from oil can onto the barrel bolt moving joint surfaces. b. Wipe away excess lubricating oil with a clean rag.	
3	Monthly	Condenser Coil	a. Inspect as much of coil as possible, without disassembly, for any evidence of refrigerant leak. If evidence of leak is found, notify direct support maintenance to repair or replace it as necessary. b. Inspect coil for obstructions. If coil is obstructed with dirt or bent fins, remove condenser coil guard (para 4-19) and clean or straighten fins as needed.	Condenser coil is obstructed or evidence of leak is found.

Table 4-1. Preventive Maintenance Checks and Services for Model F1000RE

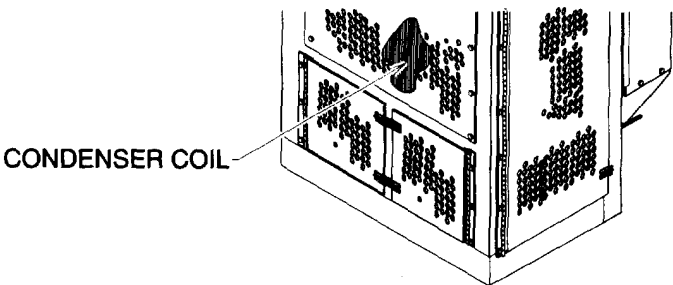
Item No.	Interval	Location	Procedure	Not Fully Mission Capable If:
		Item to Check/Service		
3- Cont				
4	Monthly	Evaporator Coil	<ol style="list-style-type: none"> (1) Clean coil if dirty. <ol style="list-style-type: none"> (a) Mix a small quantity of detergent with water to make a wash solution. (b) Dip a scrub brush in the wash solution and clean the fins by carefully brushing up and down. Continue to dip and brush as needed to loosen dirt. (c) Rinse the scrub brush with clean water and rinse the fins by carefully brushing up and down. Continue to rinse and brush as needed to clean the coil. (2) If fins are bent, carefully straighten them using fin comb. (3) Install condenser coil guard (para 4-19). <ol style="list-style-type: none"> a. Inspect as much of coil as possible, without disassembly, for any evidence of refrigerant leak. If evidence of leak is found, notify direct support maintenance to repair or replace it as necessary. b. Inspect coil for obstructions. If coil is obstructed with dirt or bent fins, remove evaporator coil guard (para 4-18) and clean or straighten fins as needed. 	Evaporator coil is obstructed or evidence of leak is found.

Table 4-1. Preventive Maintenance Checks and Services for Model F1000RE

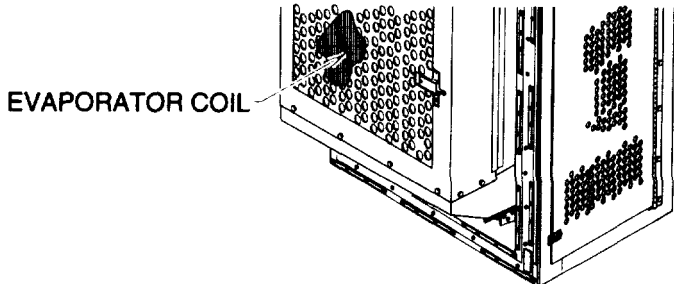
Item No.	Interval	Location	Procedure	Not Fully Mission Capable If:
		Item to Check/Service		
4- Cont			 <p>(1) Clean coil if dirty.</p> <p>(a) Mix a small quantity of detergent with water to make a wash solution.</p> <p>(b) Dip a scrub brush in the wash solution and clean the fins by carefully brushing up and down. Continue to dip and brush as needed to loosen dirt.</p> <p>(c) Rinse the scrub brush with clean water and rinse the fins by carefully brushing up and down. Continue to rinse and brush as needed to clean the coil.</p> <p>(2) If fins are bent, carefully straighten them using fin comb.</p> <p>(3) Install evaporator coil guard (para 4-18).</p>	

Table 4-1. Preventive Maintenance Checks and Services for Model F1000RE

Item No.	Interval	Location	Procedure	Not Fully Mission Capable If:
		Item to Check/Service		
5	Monthly	Refrigeration Unit Interior	Service the flange bearings by lubricating them (fig. 4-7). <ol style="list-style-type: none"> a. Wipe grease fitting with a clean rag. b. Pump grease gun handle until a flow of clean grease (MIL-G-23549) comes out nozzle. c. Attach grease gun nozzle to grease fitting and pump handle until grease just begins coming out around bearing. d. Remove grease gun nozzle and wipe away excess grease with a clean rag. 	
		Flange Bearings		
6	Monthly	Evaporator Fan	<ol style="list-style-type: none"> a. Remove evaporator air outlet guard (para 4-17). b. Inspect evaporator fan for cracks and tears. Inspect for loose connection to fan drive shaft. If loose, tighten to shaft. If damaged, replace (para 4-38). 	Fan is cracked, torn, or loose.

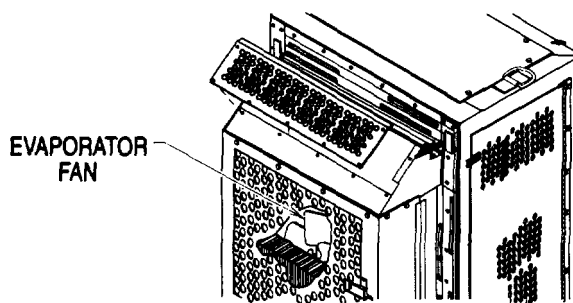


Table 4-1. Preventive Maintenance Checks and Services for Model F1000RE

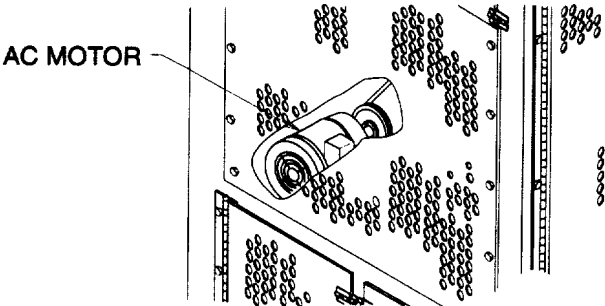
Item No.	Interval	Location	Procedure	Not Fully Mission Capable If:
		Item to Check/Service		
7	Semi-Annually	<p>Refrigeration Unit Interior</p> <p>AC Motor</p>	<p>Inspect AC motor for evidence of overheating in the form of discolored or blistered paint. Check for loose or missing mounting hardware and loose shaft. If evidence of overheating is observed or the shaft is loose, replace motor (para 4-35). If mounting hardware is loose or missing, tighten or replace as necessary (para 4-35).</p>	<p>Evidence of overheating is found. Shaft is loose, mounting hardware is loose or missing.</p>
				
8	Semi-Annually	<p>Control Box Interior</p> <p>Fuse</p>	<p style="text-align: center;">NOTE</p> <p style="text-align: center;">The control box must be open for all interior control box PMCS.</p> <p>a. Open the control box (para 4-23).</p> <p>b. Check for loose or missing fuse block mounting hardware, loose wire leads, and loose fuse block clips. If mounting hardware or leads are loose, tighten or replace as necessary (para 4-23). If fuse block clips are loose, replace fuse block (para 4-23).</p> <p>c. Check fuse for broken link or discoloration of case. Replace fuse if link is broken or case is discolored (para 4-23).</p>	<p>Wire lead or fuse clip loose. Fuse link is broken or fuse case is discolored.</p>

Table 4-1. Preventive Maintenance Checks and Services for Model F1000RE

Item No.	Interval	Location	Procedure	Not Fully Mission Capable If:
		Item to Check/Service		
9	Semi-Annually	Motor Starter	<ul style="list-style-type: none"> a. Check for loose or missing mounting hardware and wire terminals. Tighten or replace as necessary (para 4-24). b. Inspect case for cracks, breaks, or evidence of overheating. Replace if damaged (para 4-24). 	Mounting hardware or wire terminals are loose. Case is damaged.
10	Semi-Annually	Control Relays	<ul style="list-style-type: none"> a. Check for loose or missing mounting hardware and wire terminals. Tighten or replace as necessary (para 4-26). b. Inspect case for cracks, breaks, or evidence of overheating. Replace if damaged (para 4-26). 	Mounting hardware or wire terminals are loose. Case is damaged.
11	Semi-Annually	Contactor (Power Relay)	<ul style="list-style-type: none"> a. Check for loose or missing mounting hardware and wire terminals. Tighten or replace as necessary (para 4-25). b. Inspect case for cracks, breaks, or evidence of overheating. Replace if damaged (para 4-25). 	Mounting hardware or wire terminals are loose. Case is damaged.

Table 4-1. Preventive Maintenance Checks and Services for Model F1000RE

Item No.	Interval	Location	Procedure	Not Fully Mission Capable If:
		Item to Check/Service		
12	Semi-Annually	Repeat Cycle Timer	<ul style="list-style-type: none"> a. Check for loose or missing mounting socket hardware and wire terminals. Tighten or replace as necessary (para 4-29). b. Inspect case and mounting socket for cracks, breaks, or evidence of overheating. Replace if damaged (para 4-29). c. Check and adjust the timer controls if needed (para 4-8). 	Mounting hardware or wire terminals are loose. Case is damaged.
13	Semi-Annually	Remote Bulb Thermostat	<ul style="list-style-type: none"> a. Remove cover and check for loose or missing mounting hardware and wire terminals. Tighten or replace as necessary (para 4-30). wire terminals are loose. b. Inspect for kinked or broken sensing bulb capillary line. If damaged, replace remote bulb thermostat (para 4-30). c. Close the control box (para 4-30). 	Sensing bulb capillary line is kinked or broken. Mounting hardware or
		Refrigeration Unit Exterior	<p style="text-align: center;">NOTE</p> <p>The evaporator coil guard must be removed for the following semi-annual PMCS.</p>	
14	Semi-Annually	Defrost Temperature Switch	<ul style="list-style-type: none"> a. Remove the evaporator coil guard (para 4-18). b. Inspect for frayed or broken wire leads. If damaged, repair or replace as needed (para 4-20). c. Check that the mounting hardware is secure and the switch is in contact with the tubing. Tighten the mounting hardware if loose 	Wire lead frayed or broken. Defrost temperature switch loose on tubing.

Table 4-1. Preventive Maintenance Checks and Services for Model F1000RE

Item No.	Interval	Location	Procedure	Not Fully Mission Capable If:
		Item to Check/Service		
<p>The diagram illustrates the refrigeration system components. It shows a cross-section of the evaporator coil (Heat Exchanger) with a capillary line leading to an expansion valve. A sensing bulb is connected to the capillary line and is mounted on the defrost temperature switch. Labels include: HEAT EXCHANGER, CAPILLARY LINE, EXPANSION VALVE, SENSING BULB, and DEFROST TEMPERATURE SWITCH.</p>				
15	Semi-Annually	Heat Exchanger	Inspect the heat exchanger for dents or evidence of refrigerant leak. If damaged or evidence of leaking found, notify direct support maintenance to replace it.	Heat exchanger is dented or evidence of leak is found.
16	Semi-Annually	Expansion Valve	<ol style="list-style-type: none"> Inspect the expansion valve for evidence of refrigerant leak. If evidence or leak is found, notify direct support maintenance to replace it. Inspect the sensing bulb capillary line for cracks, kinks, or breaks. If damaged, notify direct support maintenance to replace the expansion valve. Check that the sensing bulb mounting hardware is secure and the bulb is in contact with the tubing. Tighten the mounting hardware if loose. Install the evaporator coil guard (para 4-18). 	Evidence of leak is found, sensing bulb is loose on tubing, or capillary line is kinked or broken.
17	Annually	<u>Refrigeration Unit Interior</u> Wires, Cables, and Harnesses	Inspect for frayed or broken wire leads. If damaged, repair or replace as needed (para 4-20).	Wire lead frayed or broken.

Table 4-1. Preventive Maintenance Checks and Services for Model F1000RE

Item No.	Interval	Location	Procedure	Not Fully Mission Capable If:
		Item to Check/Service		
18	Annually	Power Distribution Block	a. Open enclosure assembly. b. Inspect for cracked or broken distribution block and loose or missing mounting hardware. If damaged, replace (para 4-33). If mounting hardware is loose or missing, tighten or replace as necessary (para 4-33).	Power distribution block cracked or broken. Mounting hardware loose or missing.

4-11. MANDATORY REPLACEMENT PARTS.

The table below lists all items that must be replaced during PMCS whether they have failed or not. The table reflects the interval at which these items must be replaced whether hardtime maintenance or on condition maintenance is the determining factor.

Table 4-2. Semi-Annually Mandatory Replacement Parts

Item No.	Part Number	National Stock Number	Nomenclature	Qty
1	500K1950-3		Washer, Lock	2
2	500K1950-2		Washer, Lock	16

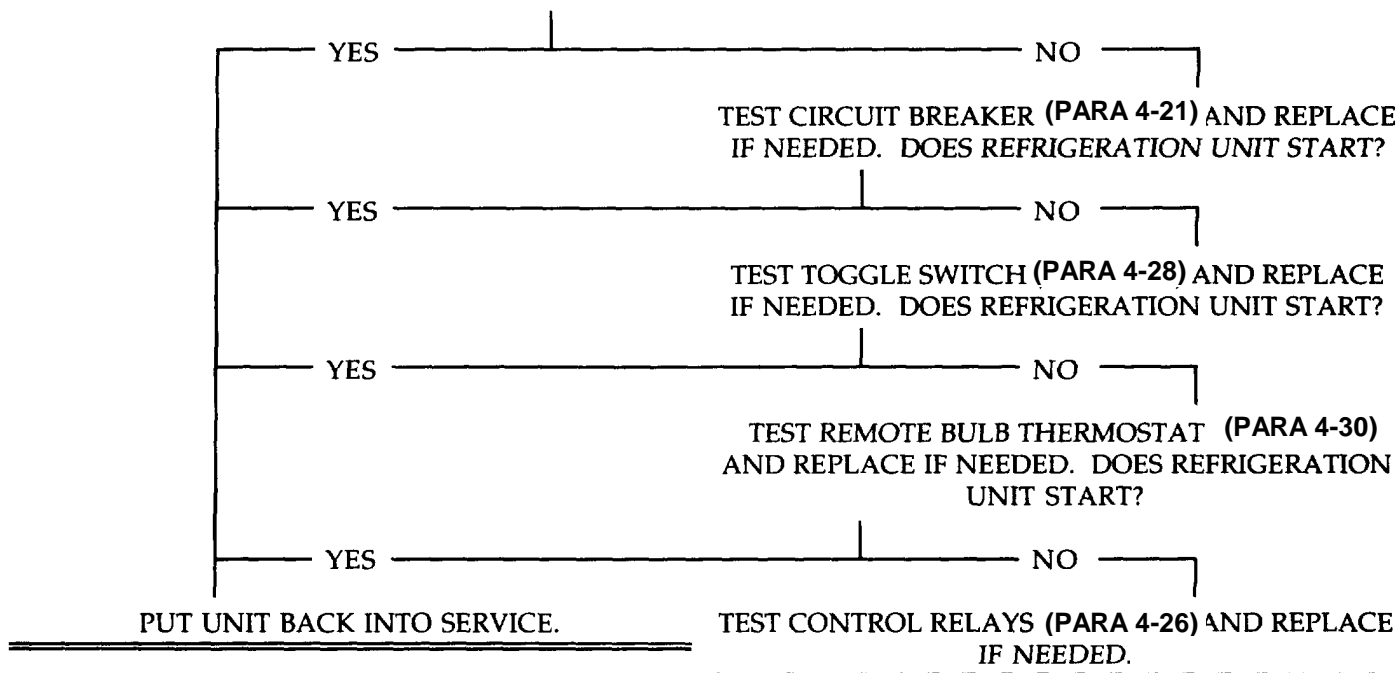
SECTION IV TROUBLESHOOTING INSTRUCTIONS

4-12. TROUBLESHOOTING.

The following procedures are listed in order of the most probable malfunctions. Each malfunction is followed by test or inspection procedures in logical order to isolate and identify the fault and actions required to correct it. This section cannot list all the possible malfunctions that may occur with the equipment. If a malfunction occurs that is not listed or actions listed do not correct a malfunction, notify your supervisor.

a. Refrigeration Unit Does Not Start.

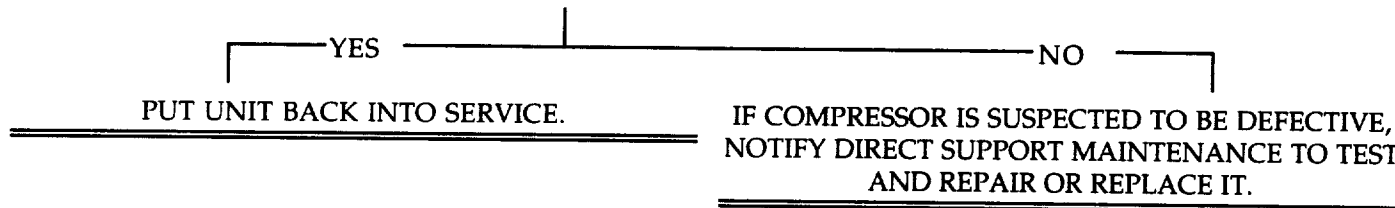
TEST FUSES (PARA 4-23) AND REPLACE IF NEEDED.
DOES REFRIGERATION UNIT START?



4-12. **TROUBLESHOOTING.** - Continued

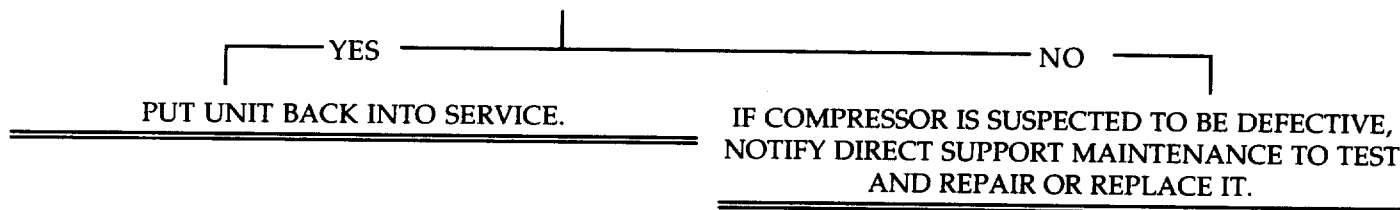
b. Circuit Breaker Trips.

TEST AC MOTOR (PARA 4-35) AND REPLACE IF NEEDED. DOES REFRIGERATION UNIT START?



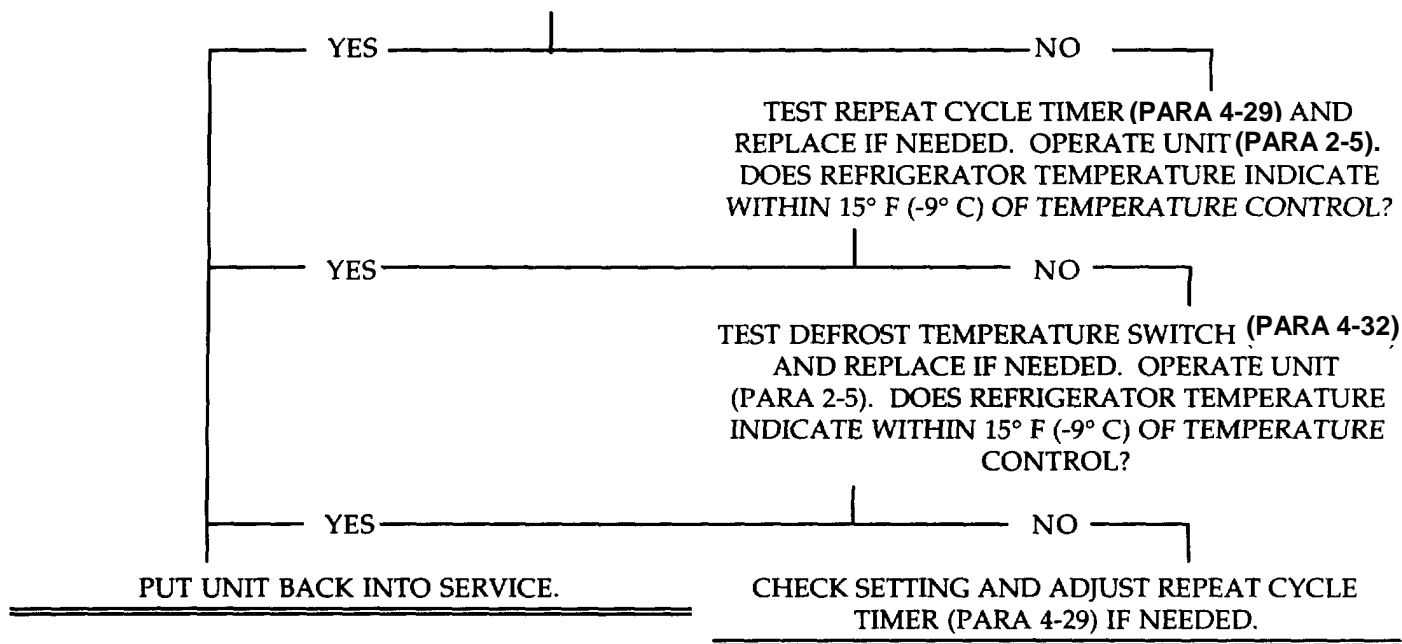
c. Reset Button Trips.

TEST MOTOR STARTER (PARA 4-24) AND REPLACE STARTER OR THERMAL OVERLOAD HEATER IF NEEDED. DOES REFRIGERATION UNIT START



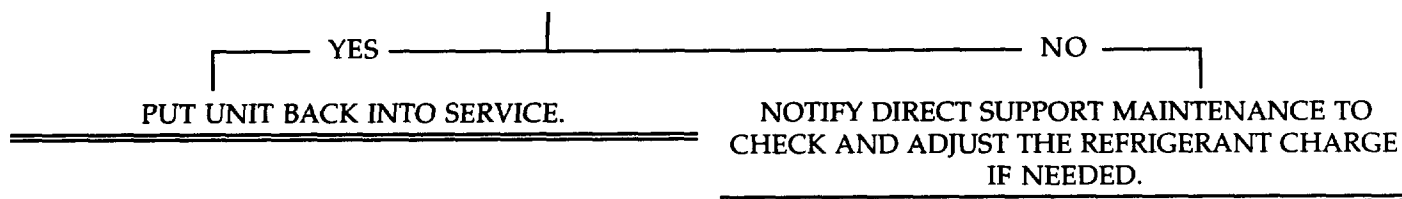
d. Thermometer (Refrigerator Temperature) Indicates More Than 15° F (-9° C) Above or Below Remote Bulb Thermostat (Temperature Control) Setting.

TEST REMOTE BULB THERMOSTAT (PARA 4-30) AND REPLACE IF NEEDED. OPERATE UNIT (PARA 2-5). DOES REFRIGERATOR TEMPERATURE INDICATE WITHIN 15° F (-9°C) OF TEMPERATURE CONTROL?



e. Pressure Gage (Discharge Pressure) Indicates Above 250 psi (1725 kPa).

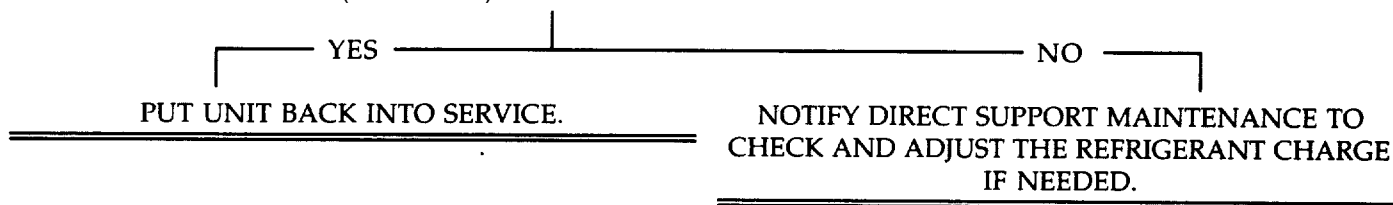
OPEN ALL REFRIGERATION VALVES (PARA 4-7). IF ANY VALVES WERE CLOSED, OPERATE UNIT (PARA 2-5). IS DISCHARGE PRESSURE BELOW 250 PSI (1725 kPa)?



4-12. **TROUBLESHOOTING.** - Continued

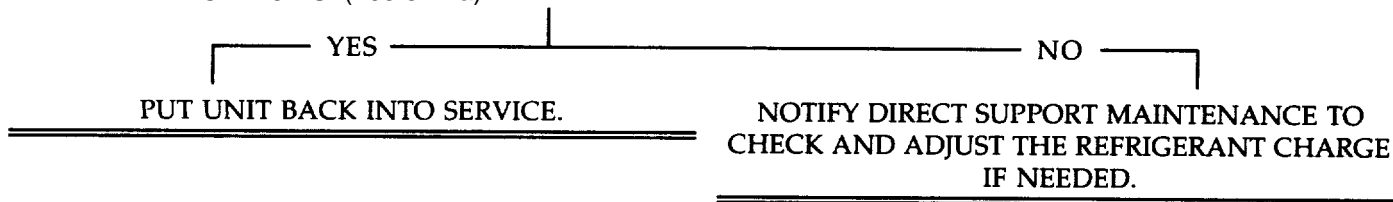
f. Pressure Gage (Discharge Pressure) Indicates Below 165 psi (1138.5 kPa).

OPEN ALL REFRIGERATION VALVES (PARA 4-7). IF ANY VALVES WERE CLOSED, OPERATE UNIT (PARA 2-5). IS DISCHARGE PRESSURE ABOVE 165 PSI (1138.5 kPa)?



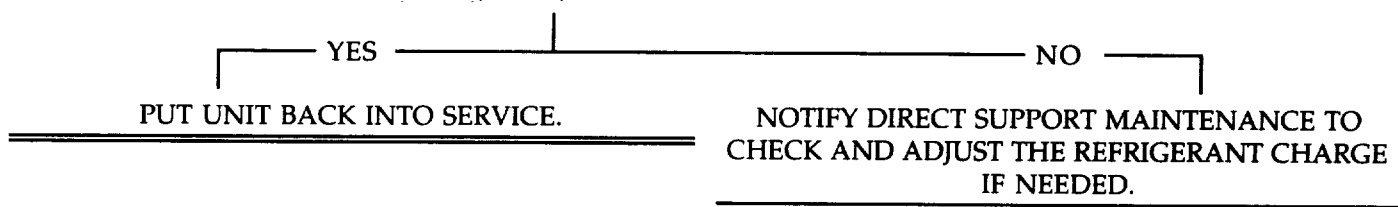
g. Compound Gage (Suction Pressure) Indicates Above 15 psi (103.5 kPa).

OPEN ALL REFRIGERATION VALVES (PARA 4-7). IF ANY VALVES WERE CLOSED, OPERATE UNIT (PARA 2-5). IS SUCTION PRESSURE BELOW 15 PSI (103.5 kPa)?



h. Compound Gage (Suction Pressure) Indicates Below 0 psi (0 kPa).

OPEN ALL REFRIGERATION VALVES (PARA 4-7). IF ANY VALVES WERE CLOSED, OPERATE UNIT (PARA 2-5). IS SUCTION PRESSURE ABOVE 0 PSI (0 kPa)?



SECTION V UNIT MAINTENANCE INSTRUCTIONS

4-13. CONDENSER TOP PANEL REPLACEMENT.

 This task covers: a. Removal b. Installation

INITIAL SETUP**Equipment Conditions:**

Refrigeration unit shut down (para 2-7) and power disconnected.

Materials/Parts:

Lock Washers (7)
1, Appendix G

General Safety Instructions:**WARNING**

High voltage and exposed rotating parts are used in the refrigeration unit. Personal injury can result if power is connected.

-
- a. Removal. Remove seven bolts (1), lock washers (2), and panel (3). Discard lock washers.
b. Installation. Install panel (3), seven new lock washers (2), and bolts (1).

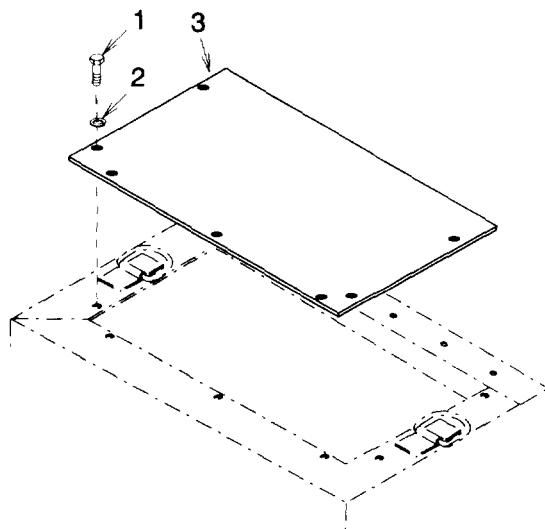


Figure 4-8. Top Panel

NOTE

FOLLOW-ON MAINTENANCE:
Connect power and put unit back into service.

4-14. CONDENSER SIDE DOORS AND BARREL BOLTS REPLACEMENT.

This task covers: a. Removal b. Installation

INITIAL SETUP**Equipment Conditions:**

Refrigeration unit shut down (para 2-7) and power disconnected.

Condenser door open.

Materials/Parts:

Lock Washers (9) (Each Door)

1, Appendix G

Lock Washers (6) (Each Barrel Bolt Assembly)

1, Appendix G

General Safety Instructions:**WARNING**

High voltage and exposed rotating parts are used in the refrigeration unit. Personal injury can result if power is connected.

a. Condenser Side Door Replacement.

(1) Removal. Remove nine bolts (1), lock washers (2), flat washers (3), and door (4). Discard lock washers.

(2) Installation.

(a) Remove four bolts (5), lock washers (6), and barrel bolt (7) from old door (4). Repeat for second barrel bolt. Discard lock washers.

(b) Install barrel bolt (7), four new lock washers (6), and bolts (5). Repeat for second barrel bolt.

(c) Install door (4), nine flat washers (3) new lock washers (2), and bolts (1).

b. Barrel Bolt Replacement.

(1) Removal.

(a) Remove four bolts (5), lock washers (6), and barrel bolt (7). Discard lock washers.

(b) Remove two screws (8), lock washers (9), barrel bolt clip (10), and shim (11). Discard lock washers.

(2) Installation.

(a) Install shim (11), barrel bolt clip (10), two new lock washers (9), and screws (8).

(b) Install barrel bolt (7), four new lock washers (6), and bolts (5).

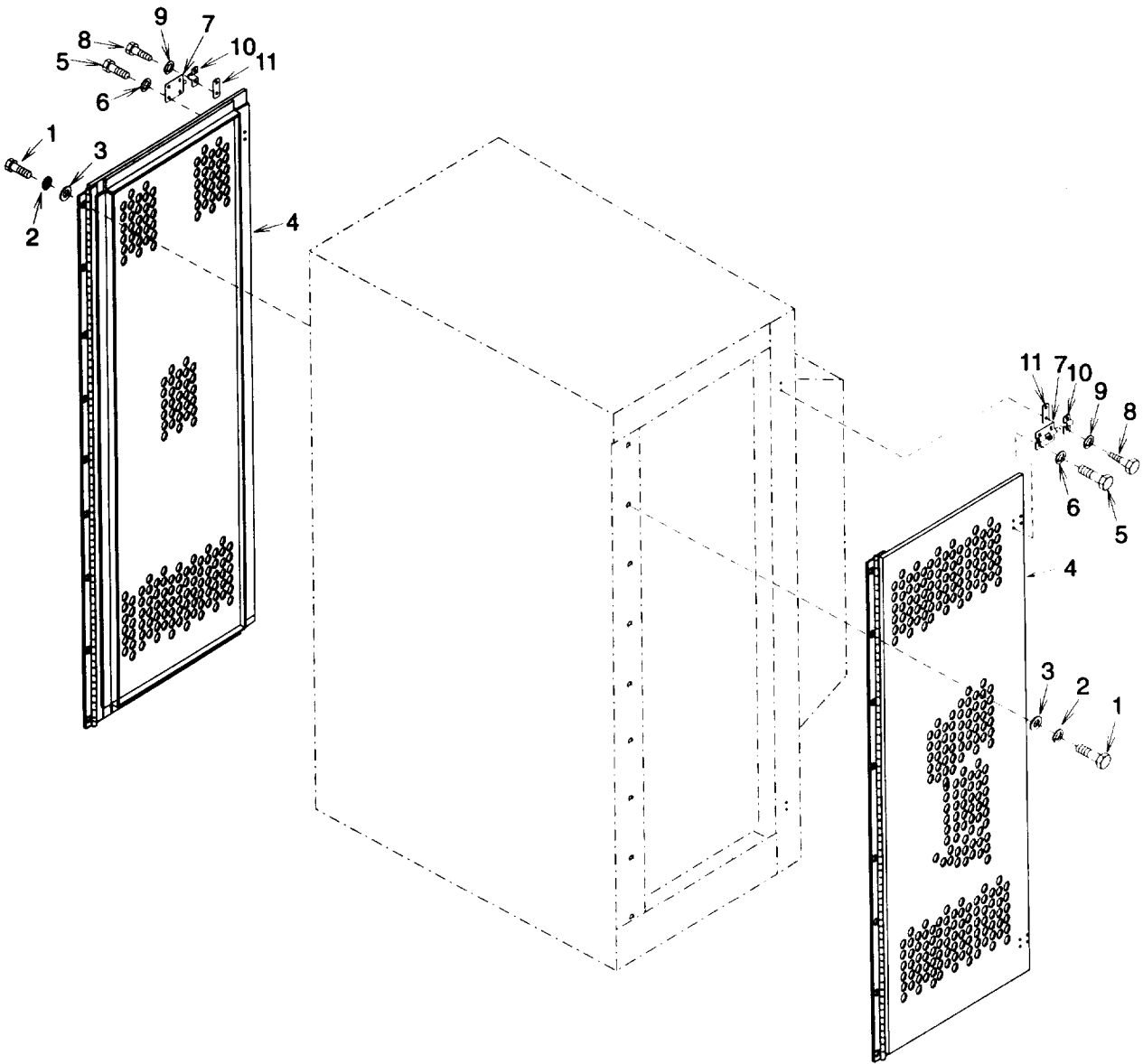


Figure 4-9. Condenser Side Doors and Barrel Bolts

NOTE

FOLLOW-ON MAINTENANCE:
 Close condenser side door.
 Connect power and put unit back into service.

4-15. FRONT BOTTOM DOORS AND BARREL BOLTS REPLACEMENT.

This task covers: a. Removal b. Installation

INITIAL SETUP**Equipment Conditions:**

Refrigeration unit shut down (para 2-7) and power disconnected.

Materials/Parts:

Lock Washers (3 each door)
 1, Appendix G
 Lock Washers (6 each barrel bolt assembly)
 1, Appendix G
 Self Locking Nut (4)
 12 Appendix G

General Safety Instructions:**WARNING**

High voltage and exposed rotating parts are used in the refrigeration unit. Personal injury can result if power is connected.

a. **Condenser Side Door Replacement.**

- (1) **Removal.** Remove three bolts (1), lock washers (2), and door (3). Discard lock washers.
- (2) **Installation.**
 - (a) Remove four bolts (4), lock washers (5), and barrel bolt (6) from old door (3). Repeat for second barrel bolt. Discard lock washers.
 - (b) Install barrel bolt (6), four new lock washers (5), and bolts (4). Repeat for second barrel bolt.
 - (c) Install door (3), three new lock washers (2), and bolts (1).

b. **Barrel Bolt Replacement.**

- (1) **Removal.**
 - (a) Remove four bolts (4), lock washers (5), and barrel bolt (6). Discard lock washers.
 - (b) Remove two screws (7), lock washers (8), barrel bolt clip (9), and shim (10). Discard lock washers.
- (2) **Installation.**
 - (a) Install shim (10), barrel bolt clip (9), two new lock washers (8), and screws (7).
 - (b) Install barrel bolt (6), four new lock washers (5), and bolts (4).

c. **Center Post Replacement.**

- (1) **Removal.** Remove four self locking nuts (11), bolts (12), and center post (13). Discard self locking nuts.

(2) Installation.

- (a) Remove four bolts (4), lock washers (5), and barrel bolt (6) from old door (3). Repeat for second barrel bolt. Discard lock washers.
- (c) Install barrel bolt (6), four new lock washers (5), and bolts (4). Repeat for second barrel bolt.
- (d) Install center post (13), four bolts (12), and new self locking nuts (11).

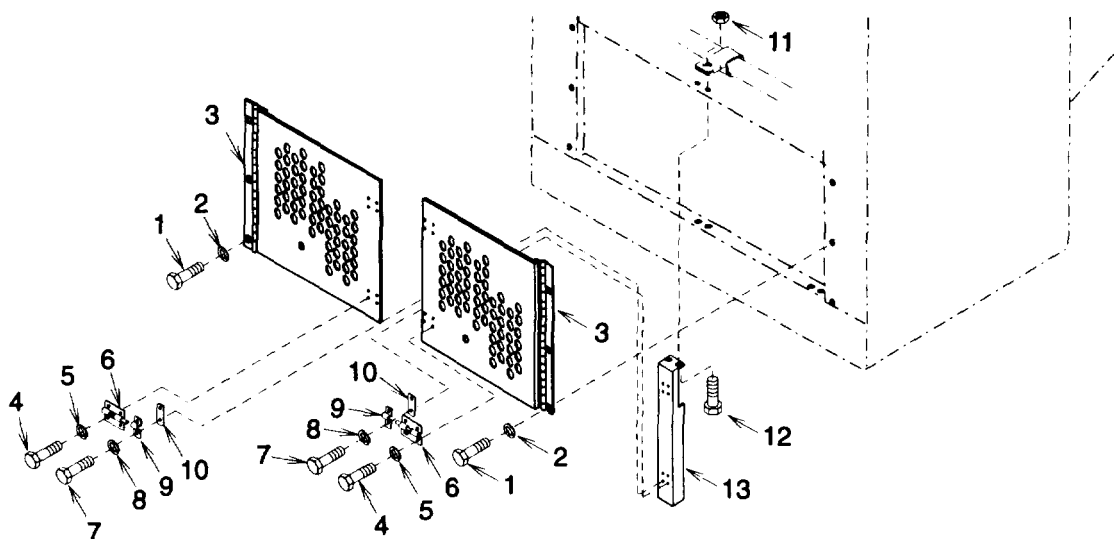


Figure 4-10. Front Bottom Doors and Barrel Bolts

NOTE

FOLLOW-ON MAINTENANCE:
 Close front bottom door.
 Connect power and put unit back into service.

4-16. CONTROL PANEL COVER, DOOR HOLDER CLIPS, AND BARREL BOLTS REPLACEMENT.

This task covers: a. Removal b. Installation

INITIAL SETUPTools:

Drill Motor
1, Section III, Appendix B
Drill
1, Section III, Appendix B
Rivet Gun
1, Section III, Appendix B

Equipment Conditions:

Refrigeration unit shut down (para 2-7) and power disconnected.
Control panel cover open.

Materials/Parts:

Lock Washers (6 each barrel bolt assembly)
1, Appendix G
Lock Washers (5)
3, Appendix G
Rivets (4 each identification plate)
4, Appendix G
Rivet (1 each door holder clip)
5, Appendix G

General Safety Instructions:**WARNING**

High voltage and exposed rotating parts are used in the refrigeration unit. Personal injury can result if power is connected.

a. Control Panel Cover Replacement.

- (1) Removal. Remove five bolts (1), lock washers (2), flat washers (3), and control panel cover (4). Discard lock washers.
- (2) Installation.
 - (a) Remove two bolts (5), lock washers (6), and barrel bolt clip (7) from old cover (4). Repeat for second barrel bolt clip. Discard lock washers.
 - (b) Install barrel bolt clip (7), two new lock washers (6), and bolts (5). Repeat for second barrel bolt clip.
 - (c) Drill out four rivets (8) and identification plate (9) from old cover (4). If the rivets cannot be removed, notify direct support maintenance to remove them.
 - (d) Install identification plate (9) and four new rivets (8). If the rivets cannot be installed, notify direct support maintenance to install them.
 - (e) Drill out four rivets (10) and warranty plate (11) from old cover (4). If the rivets cannot be removed, notify direct support maintenance to remove them.
 - (f) Install warranty plate (11) and four new rivets (10). If the rivets cannot be installed, notify direct support maintenance to install them.

(g) Check control panel cover (4) for gaskets. If no gaskets are on the cover, notify direct support maintenance to install them.

(h) Install control panel cover (4), five flat washers (3), new lock washers (2), and bolts (1).

b. Barrel Bolt Replacement.

(1) Removal.

(a) Remove four bolts (12), lock washers (13), barrel bolt (14), and shim (15). Discard lock washers.

(b) Remove two bolts (5), lock washers (6), and barrel bolt clip (7). Discard lock washers.

(2) Installation.

(a) Install barrel bolt clip (7), two new lock washers (6), and bolts (5).

(b) Install shim (15), barrel bolt (14), four new lock washers (13), and bolts (12).

c. Door Holder Clip Replacement.

(1) Removal. Drill out rivet (16) and remove door holder clip (17). If the rivet cannot be removed, notify direct support maintenance to remove it.

(2) Installation. Install door holder clip (17) and new rivet (16).

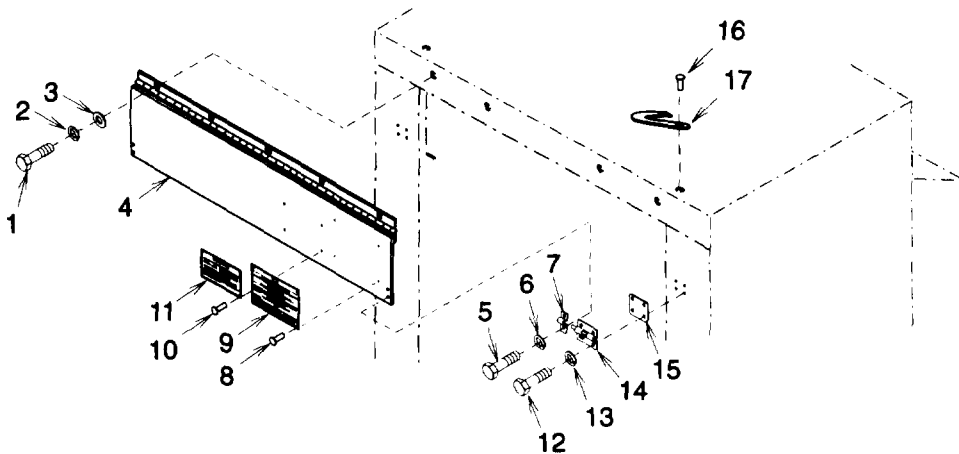


Figure 4-11. Control Panel Cover, Barrel Bolts, and Door Holder Clips.

NOTE

FOLLOW-ON MAINTENANCE:
 Close control panel cover.
 Connect power and put unit back into service.

4-17. EVAPORATOR AIR OUTLET GUARD REPLACEMENT.

This task covers: a. Removal b. Installation

INITIAL SETUP**Equipment Conditions:**

Refrigeration unit shut down (para 2-7) and power disconnected.

Materials/Parts:

Lock Washers (7)
3, Appendix G

General Safety Instructions:**WARNING**

High voltage and exposed rotating parts are used in the refrigeration unit. Personal injury can result if power is connected.

- a. **Removal.** Remove seven bolts (1), lock washers (2), flat washers (3), and evaporator air outlet guard (4). Discard lock washers.
- b. **Installation.** Install evaporator air outlet guard (4), seven flat washers (3), new lock washers (2), and bolts (1).

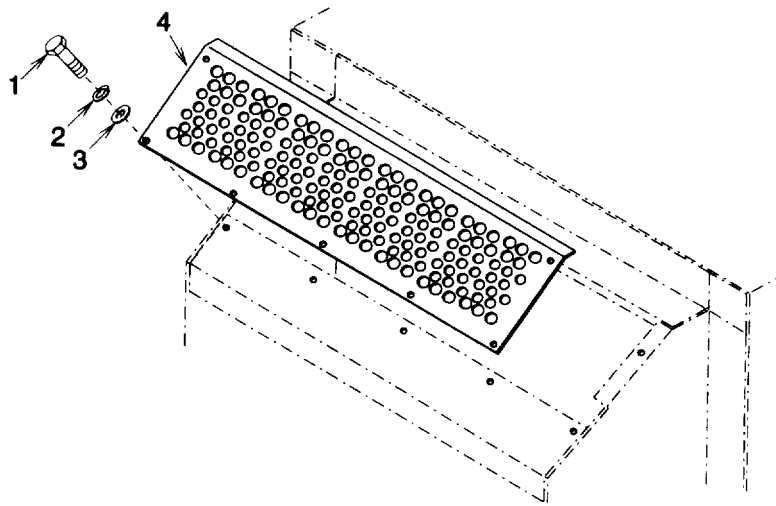


Figure 4-12. Evaporator Air Outlet

NOTE

FOLLOW-ON MAINTENANCE:
Connect power and put unit back into service.

4-18. EVAPORATOR COIL GUARD REPLACEMENT.

This task covers: a. Removal b. Installation

INITIAL SETUP

Equipment Conditions:

Refrigeration unit shut down (para 2-7) and power disconnected.

Materials/Parts:

Lock Washers (16)
3, Appendix G

General Safety Instructions:

WARNING

High voltage and exposed rotating parts are used in the refrigeration unit. Personal injury can result if power is connected.

- a. **Removal.** Remove 16 bolts (1), lock washers (2), flat washers (3), and evaporator coil guard (4). Discard lock washers.
- b. **Installation.** Install evaporator coil guard (4), 16 flat washers (3), new lock washers (2), and bolts (1).

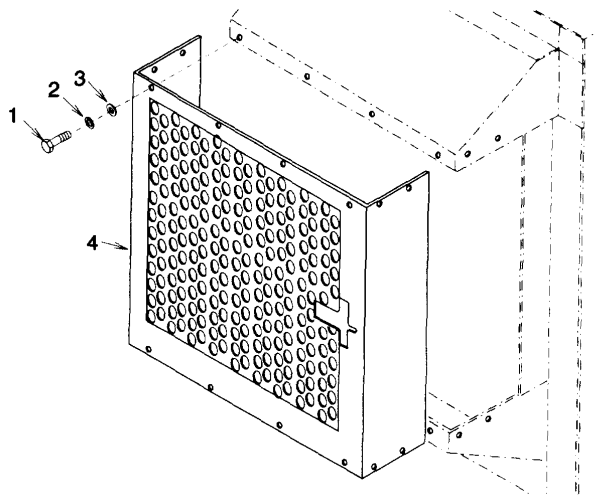


Figure 4-13. Evaporator Coil Guard

NOTE

FOLLOW-ON MAINTENANCE:
Connect power and put unit back into service.

4-19. CONDENSER GUARD REPLACEMENT.

This task covers: a. Removal b. Installation

INITIAL SETUP**Equipment Conditions:**

Refrigeration unit shut down (para 2-7) and power disconnected.

Materials/Parts:

Lock Washers (10)
1, Appendix G

General Safety Instructions:**WARNING**

High voltage and exposed rotating parts are used in the refrigeration unit. Personal injury can result if power is connected.

- a. **Removal.** Remove 10 bolts (1), lock washers (2), flat washers (3), and condenser guard (4). Discard lock washers.
- b. **Installation.** Install condenser guard (4), 10 flat washers (3), new lock washers (2), and bolts (1).

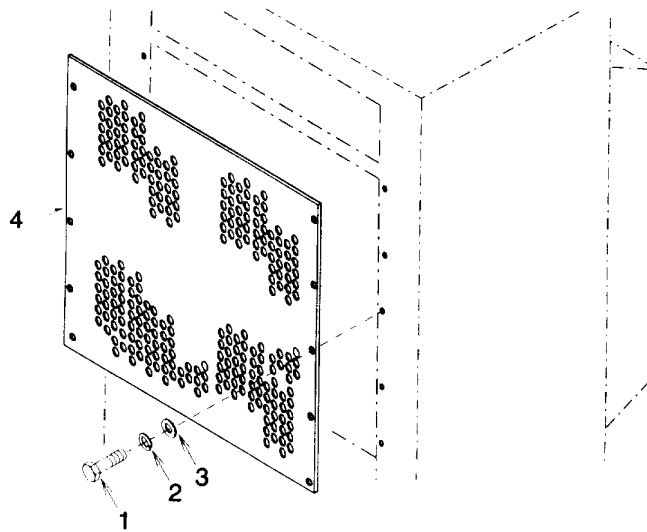


Figure 4-14. Condenser Guard

NOTE

FOLLOW-ON MAINTENANCE:
Connect power and put unit back into service.

4-20. WIRES, CABLES, AND HARNESES TESTING, REPAIR, AND REPLACEMENT.

This task covers: a. Testing b. Repair c. Removal d. Installation

INITIAL SETUPTools:

Heat Gun

4, Section III, Appendix B

Soldering Gun

1, Section III, Appendix B

Electrical Connector Repair Tool Kit

1, Section III, Appendix B

Materials/Parts:

Wire (As Required)

Insulation Sleeving (As Required)

F-19, Appendix F

Lockwashers (2)

1, Appendix G

Solder

8, Appendix E

Flux

9, Appendix E

Marker Tag(s) (As Required)

7, Appendix E

Tiedown Strap(s) (As Required)

10, Appendix E

Silicone RTV

20, Appendix E

Equipment Conditions:

Refrigeration unit shut down (para 2-7) and power disconnected.

Side condenser doors open if needed.

Control panel cover open.

Enclosure assembly open if needed.

General Safety Instructions:**WARNING**

High voltage and exposed rotating parts are used in the refrigeration unit. Personal injury can result if power is connected.

a. Testing.

- (1) Be sure power has been disconnected at the source and remove two bolts (1) and lock washers (2). Open control box cover (3). Discard lock washers.
- (2) Tag and disconnect wire leads from components as necessary to isolate the wire or harness being tested.
- (3) Using multimeter set to measure continuity, check each end of the wire lead(s).
- (4) Replace any wire lead(s) that do not show continuity.
- (5) Connect wire lead(s) per tag and wiring diagram (fig. 1-4).

4-20. WIRES, CABLES, AND HARNESSES TESTING, REPAIR, AND REPLACEMENT. - Continued

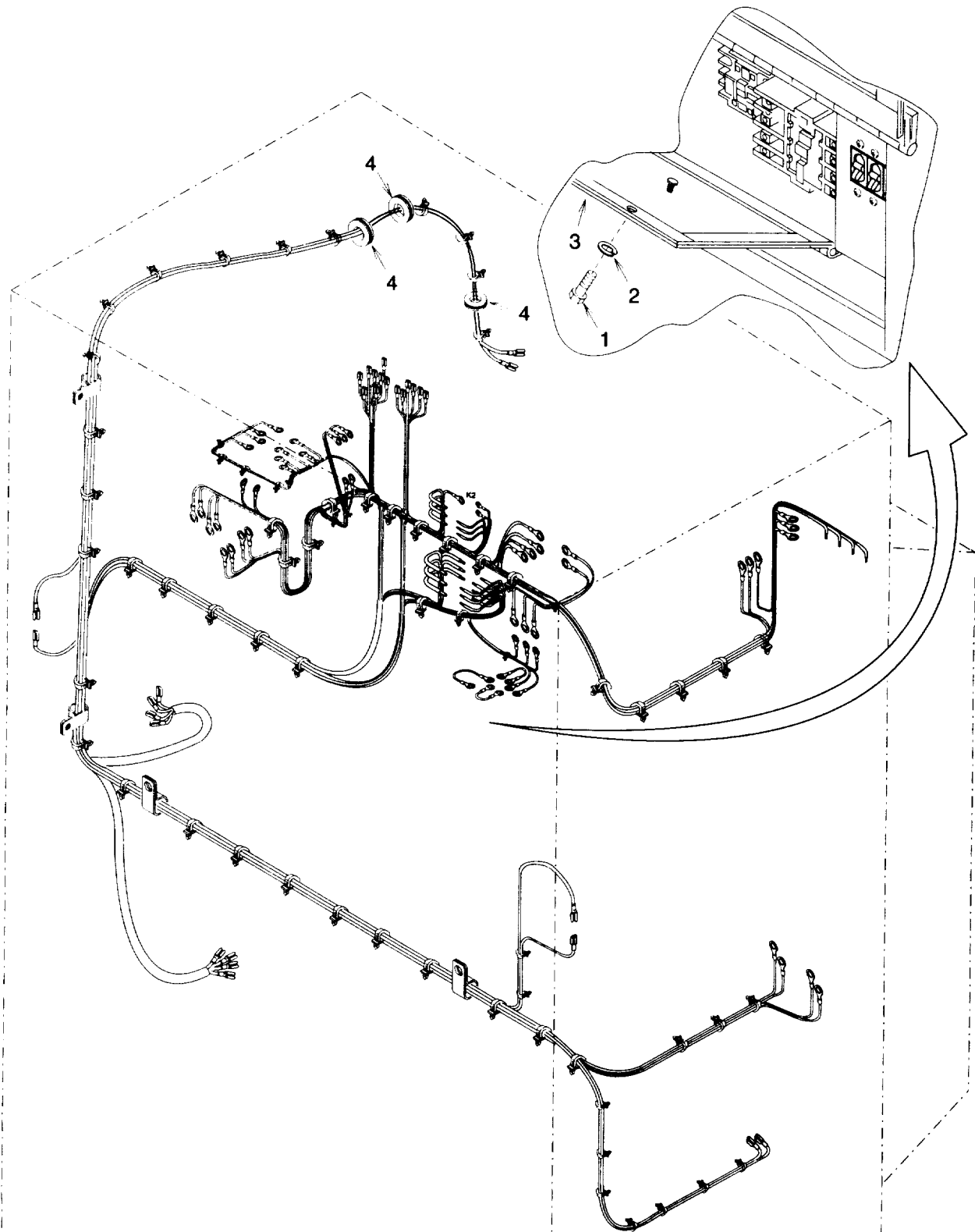


Figure 4-15. Wires Cables and Harnesses

- b. Repair. Repairs can be performed to replace terminal ends or to splice wire when cut.

WARNING

Solder and flux contain materials which are hazardous to health. Avoid breathing vapors or fumes from soldering operations. Perform operations only in well ventilated areas. Wash hands with soap and water after handling solder and flux. Wear thermal gloves and protective goggles or face shield to protect against burns.

- (1) Soldering Connections. Wire connections must be made mechanically sound before they are soldered; solder alone does not provide sufficient strength to prevent breakage. Joining surfaces of connections to be soldered must be clean and bright. Flux should be brushed onto the joint before soldering. Wires should always be heated to the point at which the solder will melt completely and flow into all parts of the joint. Excessive build up of solder "gobs" on the joint should be avoided or removed.
- (2) Insulating Joints. The preferred method of insulating electrical joints is by the use of heat-shrink tubing. To apply, cut a piece of heat-shrink tubing of suitable diameter to a length of 1 inch (2.5 cm) for covering joints at terminals or connectors, or to a length about 1/2 inch (1.3 cm) longer than the joint to be insulated. Slide the tubing over the wire before making the joint. After the joint is made, slide the tubing so that it covers the joint and shrink in place with moderate heat.
- (3) Splicing Wire. To repair broken or cut wires that are otherwise sound, the mating ends can be stripped and spliced. Solder and apply insulation as described above.
- (4) Crimping Terminals. To install a terminal on the end of a wire, strip 1/4-1/2 inch (0.6-1.3 cm) of insulation from the end of the wire and apply a one inch (2.4 cm) piece of heat shrink tubing (if the terminals are of the uninsulated type). Insert wire-end into the shank of the terminal. Crimp the shank and install heat-shrink tubing, if necessary.

NOTE

Preferred repair methods consist of replacing wires, terminals, connectors, etc., rather than splicing wires, bending ends to form terminals, and other make shift procedures, although the latter may be appropriate for emergency field repairs.

- (5) Determine the proper size and length of the wire, or terminal, or connector to be used for replacement by referring to the wire list (table 4-3), and to the wiring diagram (fig. 1-4).

Table 4-3. Wire List

TERMINATION		TERMINATION		AWG WIRE SIZE	LENGTH	
FROM	TERMINAL TYPE	TO	TERMINAL TYPE		IN.	CM
CB1-A2	MS25036-157	KI-LI		12 AWG-WHT	24.00	60.96
CB1-B2	MS25036-157	K1-L2		12 AWG-WHT	24.00	60.96
CB1-C2	MS25036-157	K1-L3		12 AWG-WHT	24.00	60.96
K1-LI		K2-L1		14 AWG-WHT	12.00	30.48
K1-L2		K2-L2		14 AWG-WHT	12.00	30.48
K1-L3		K2-L3		14 AWG-WHT	12.00	30.48
K1-L2		FI-1	MS25036-153	14 AWG-WHT	12.00	30.48
K1-L3		F2-1		14 AWG-WHT	12.00	30.48
OLI-TI		BI-1	12712937-1 (19200)	SEE NOTE	1100.00	254.00
			12712936 (19200)			
OL2-T2		B1-2	12712937-1 (19200)	SEE NOTE 1	100.00	254.00
			12712936 (19200)	WHT		
OL3-T3		B1-3	12712937-1 (19200)	SEE NOTE 1	100.00	254.00
			12712936 (19200)			
GND	MS25036-157	B1-GND	MS25036-112	SEE NOTE 1	100.00	254.00
			GRN			
K1-AI		TM1-1	MS25036-103	18 AWG-WHT	30.00	76.20
K1-A2		K2-A2		18 AWG-WHT	12.00	30.48
K1-A2		F2-2	MS25036-102	18 AWG-WHT	12.00	30.48
K1-96		S5-M	MS25036-102	18 AWG-WHT	106.00	269.24
K1-95		S5-2	MS25036-102	18 AWG-WHT	104.00	264.16
K2-T1		B2-1	12712937-1 (19200)	SEE NOTE 2	102.00	259.08
			12712936 (19200)	BLK		
K2-T2		B2-3	12712937-1 (19200)	SEE NOTE 2	102.00	259.08
			12712936 (19200)	RED		
K2-T3		B2-2	12712937-1 (19200)	SEE NOTE 2	102.00	259.08
			12712936 (19200)			
GND	MS25036-108	B2-GND	MS25036-108	SEE NOTE 2	102.00	259.08
				GRN		
K2-A1		TM1-1	MS25036-102	18 AWG-WHT	24.00	60.96
K2-A2		K3-B	13216E6191-1 (97403)	18 AWG-WHT	12.00	30.48
S7-NO	B-972 (1W654)	S1-2	MS25036-102 18	AWG-WHT	120.00	304.80
S1-2	MS25036-102	K3-7	13216E6191-1 (97403)	18 AWG-WHT	24.00	60.96

Table 4-3. Wire List

TERMINATION			TERMINATION			AWG WIRE SIZE	LENGTH	
FROM	TERMINAL	TYPE	TO	TERMINAL	TYPE		IN.	CM
K3-7	13216E6191-1	(97403)	K4-7	13216E6191-1	(97403)	18 AWG-WHT	12.00	30.48
F2-2	MS25036-149		L1-B	12712937-2	(19200)	18 AWG-WHT	120.00	304.80
				12712936	(19200)			
OL3-T3			S5-V	MS25036-102		18 AWG-WHT	108.00	274.32
F2-2	MS25036-149		L2-B	12712937-2	(19200)	18 AWG-WHT	120.00	304.80
				12712936	(19200)			
K3-4			S2-LINE	MS25036-102		18 AWG-WHT	106.00	269.24
K3-4			K4-4	MS25036-102		18 AWG-WHT	12.00	30.48
K3-A	13216E6191-1	(97403)	S3-2	MS25036-102		18 AWG-WHT	24.00	60.96
K3-B	13216E6191-1	(97403)	K4-B	13216E6191-1	(97403)	18 AWG-WHT	12.00	30.48
K4-7	13216E6191-1	(97403)	K4-9	13216E6191-1	(97403)	18 AWG-WHT	3.00	7.62
K4-A	13216E6191-1	(97403)	MI-1	MS25036-103		18 AWG-WHT	24.00	60.96
K4-6	13216E6191-1	(97403)	TM1-7	MS25036-102		18 AWG-WHT	12.00	30.48
K4-B	13216E6191-1	(97403)	TM1-B	MS25036-102		18 AWG-WHT	12.00	30.48
TM1-4	MS25036-102		DS1-1	MS25036-102		18 AWG-WHT	24.00	60.96
TM1-4	MS25036-102		L2-A	12712937-2	(19200)	18 AWG-WHT	120.00	304.80
				12712936	(19200)			
TM1-A	MS25036-102		S4-2	12712937-2	(19200)	18 AWG-WHT	113.00	287.02
				12712936	(19200)			
TM1-6	MS25036-102		S3-2	MS25036-102		18 AWG-WHT	12.00	30.48
TM1-9	MS25036-102		S1-3	MS25036-102		18 AWG-WHT	12.00	30.48
TM1-B	MS25036-102		M1-2	MS25036-103		18 AWG-WHT	12.00	30.48
S3-1	MS25036-102		S4-1	12712937-2	(19200)	18 AWG-WHT	100.00	254.00
				12712936	(19200)			
S3-1	MS25036-102		S1-3	MS25036-102		18 AWG-WHT	12.00	30.48
S3-2	MS25036-102		L1-A	12712937-2	(19200)	18 AWG-WHT	120.00	304.80
				12712936				
S2-M1	MS25036-102		S5-L	MS25036-102		18 AWG-WHT	20.00	50.80
TB1-2	MS25036-112		GND	MS25036-112		12 AWG-WHT	12.00	30.48
F1-2	MS25036-149		S6-C	B-972	(1W654)	18 AWG-WHT	100.00	254.00
S6-NO	B-972	(1W654)	S7-C	B-972	(1W654)	18 AWG-WHT	96.00	243.84
TB2-A			CB1-A1	MS25036-112		10 AWG-WHT	60.00	152.40

Table 4-3. Wire List

TERMINATION		TERMINATION		AWG WIRE SIZE	LENGTH	
FROM	TERMINAL TYPE	TO	TERMINAL TYPE		IN.	CM
TB2-B	MS25036-102 MS25036-102	CB1-B1	MS25036-112	10 AWG-WHT	60.00	152.40
TB2-C		CB1-C1	MS25036-112	10 AWG-WHT	60.00	152.40
TB2-N		TB1-1	MS25036-112	10 AWG-WHT	60.00	152.40
GND		TB1-2	MS25036-112	10 AWG-WHT	60.00	152.40
GND		FR GND	MS25036-157	10 AWG-WHT	24.00	60.96

NOTE

1 Type SO Cable, Conductor Size 12-4, 20 Amps Min. Rating 250 Vac.

2 Type SO Cable, Conductor Size 14-4, 15 Amps Min. Rating 250 Vac.

c. Removal.

- (1) Tag and disconnect wire lead(s) from component.
- (2) Remove tiedown straps and loosen clamp(s) as necessary to remove wire(s).
- (3) Remove any silicone RTV remaining in evaporator frame grommets (4).

d. Installation.

- (1) Carefully route wire lead(s) through clamp(s) and grommet(s) as necessary.
- (2) Connect wire lead(s) to component using tags and wiring diagram (fig. 1-4). Remove tags.
- (3) Install tiedown straps as necessary and tighten any clamp(s) that were loosened for removal.
- (4) Apply silicone RTV into evaporator frame grommets (4) to seal evaporator enclosure.
- (5) Close control box cover (3). Install two new lock washers (2) and bolts (1).

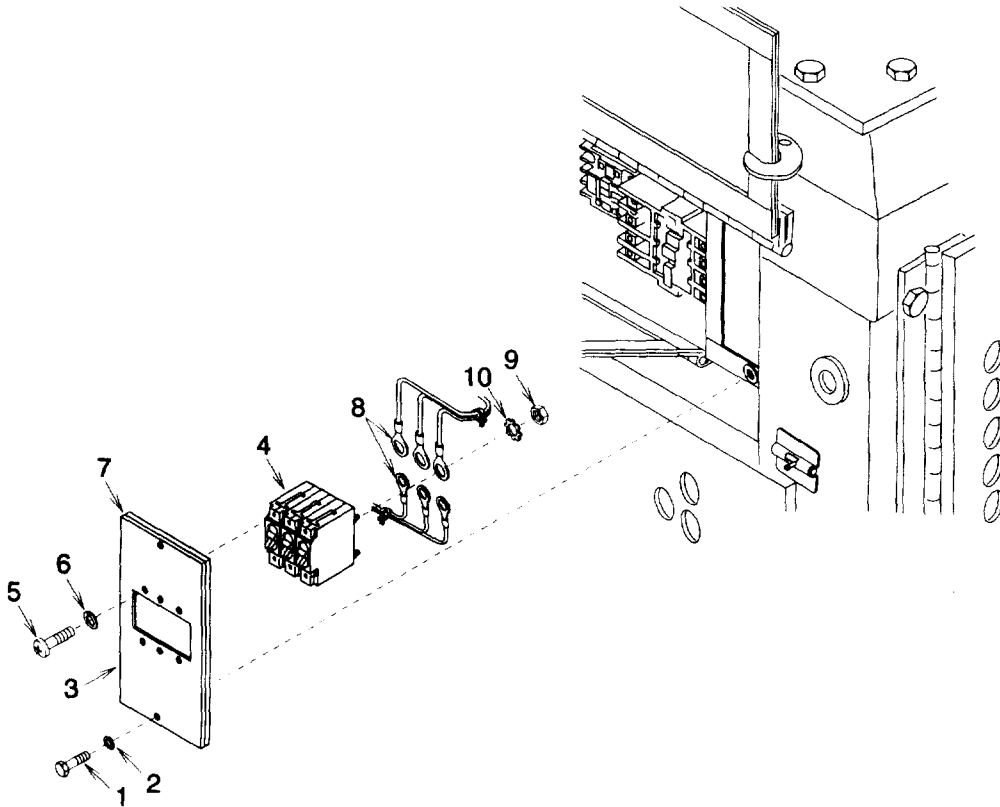
NOTE

FOLLOW-ON MAINTENANCE:
Close condenser side door if open.
Close control panel cover.
Close enclosure assembly if open.
Connect power and put unit back into service.

4-21. CIRCUIT BREAKER CB1 TESTING AND REPLACEMENT. - Continued

c. Installation.

- (1) Using tags and wiring diagram (fig. 1-4), install wire lead terminals (8), six lock washers (10), and nuts (9). Remove tags.
- (2) Install circuit breaker cover (3), six new lock washers (6), and screws (5).
- (3) Carefully push circuit breaker cover (3) into place and install two new lock washers (2) and bolts (1).

**Figure 4-16. Circuit Breaker****NOTE**

FOLLOW-ON MAINTENANCE:
Close control panel cover. See para 4-16.
Connect power and put unit back into service.

4-22. INDICATOR DS1 TESTING AND REPLACEMENT. - Continued

- (3) Close control box cover (6). Install two new lock washers (5) and bolts (4).
- (4) Install lamp (2) and indicator cap (1).

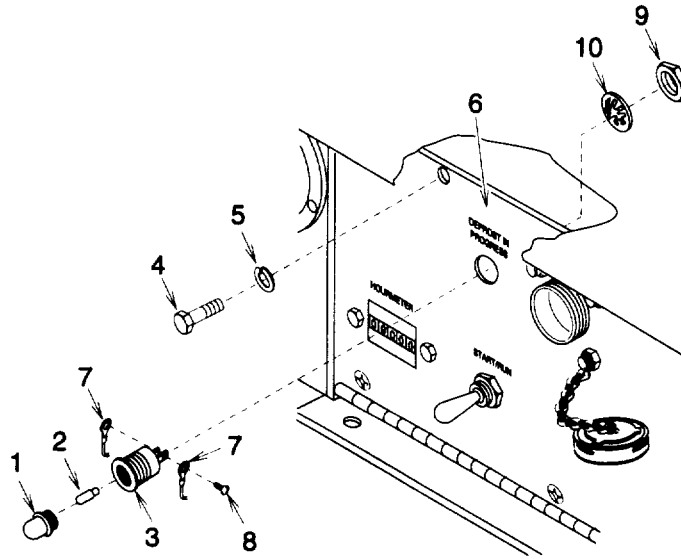


Figure 4-17. Indicator (LIGHT)

NOTE

FOLLOW-ON MAINTENANCE:
 Close control panel cover.
 Connect power and put unit back into service.

4-23. FUSES FI AND F2 TESTING AND REPLACEMENT. - Continued

c. Installation.

- (1) Install fuse block (5) and two screws (9).
- (2) Using tags and wiring diagram (fig. 1-4), install wire lead terminals (6), four lock washers (8), and screws (7). Remove tags.
- (3) Close control box cover (3). Install two new lock washers (2) and bolts (1).

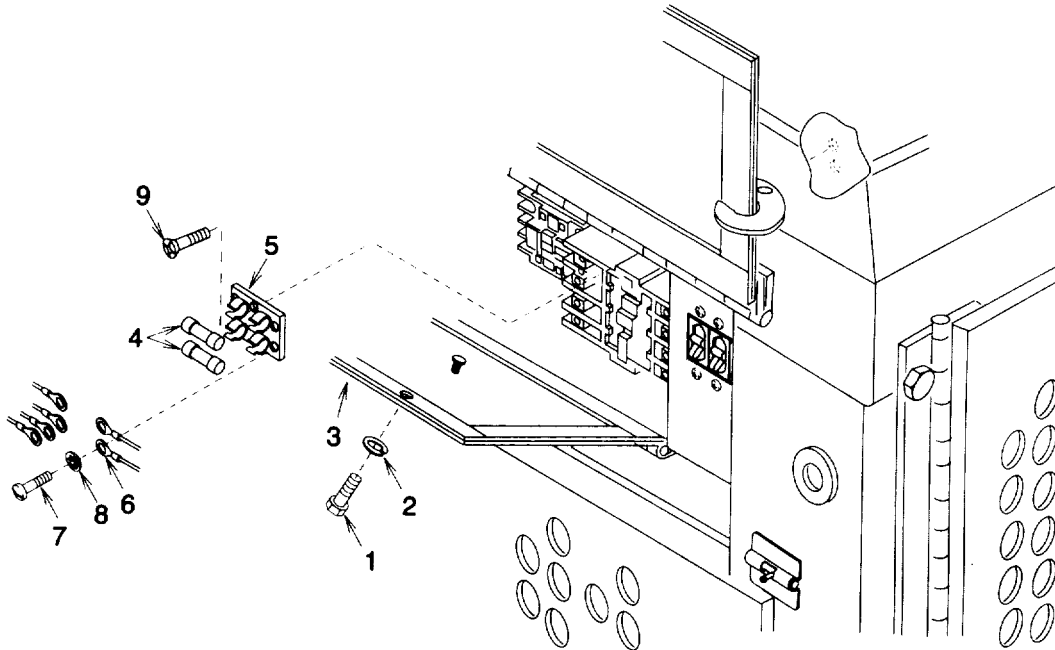


Figure 4-18. Fuses

NOTE

FOLLOW-ON MAINTENANCE:
 Close control panel cover.
 Connect power and put unit back into service.

4-24. MOTOR STARTER K1 TESTING. REPAIR. AND REPLACEMENT.

This task covers: a. Testing b. Repair c. Removal d. Installation

INITIAL SETUPMaterials/Parts:

Lock Washers (2) (Control Box Cover)
 1, Appendix G
 Lock Washers (2) (Motor Starter)
 1, Appendix G
 Marker tags (11)
 7, Appendix E

Equipment Conditions:

Refrigeration unit shut down (para 2-7) and power disconnected.

Control panel cover open.

General Safety Instructions:**WARNING**

High voltage and exposed rotating parts are used in the refrigeration unit. Personal injury can result if power is connected.

a. Testing. (See Figure 1-4.)

- (1) Be sure power has been disconnected at the source and remove two bolts (1) and lock washers (2). Open control box cover (3). Discard lock washers.
- (2) Press and hold plunger (4).
- (3) Using multimeter set to measure continuity, check each motor starter (5) contact continuity between terminals L1 to T1, L2 to T2, and L3 to T3. Continuity should be indicated.
- (4) Release plunger (4).
- (5) If no continuity was indicated, test thermal overload heaters (6) per following step.
- (6) Using multimeter set to measure continuity, check each thermal overload heater (6) continuity between mounting screws. Continuity should be indicated. If no continuity was indicated, replace thermal overload heater (6) to repair motor starter (5) and repeat tests.
- (7) Using multimeter set to measure continuity, check coil continuity between terminals A1 to A2. Continuity should be indicated. If no continuity was indicated, replace motor starter (5).
- (8) Press and release RESET button (7).
- (9) Using multimeter set to measure continuity, check overload contacts between terminals 95 to 96. Continuity should be indicated. If no continuity was indicated, replace motor starter (5).
- (10) Using multimeter set to measure continuity, check each motor starter (5) contact continuity between terminals L1 to T1, L2 to T2, and L3 to T3. No continuity should be indicated. If continuity was indicated, replace motor starter.
- (11) If no failure was indicated, close control box cover (3) and install two new lock washers (2) and bolts (1).

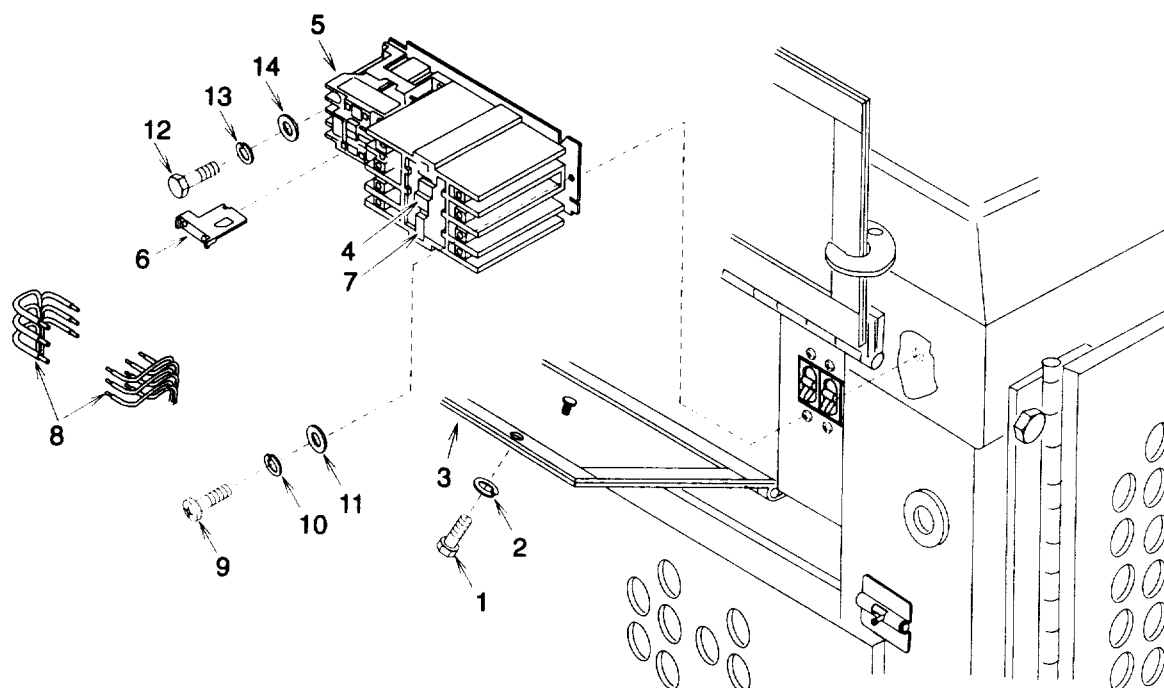
4-24. MOTOR STARTER K1 TESTING, REPAIR, AND REPLACEMENT. - Continued

b. Repair.

- (1) Remove defective thermal overload heater (6).
- (2) Install thermal overload heater (6).

c. Removal.

- (1) Be sure power has been disconnected at the source and remove two bolts (1) and lock washers (2). Open control box cover (3). Discard lock washers.

**Figure 4-19. Motor Starter**

- (2) Tag and disconnect wire leads (8).
- (3) Remove screw (9), lock washer (10), and flat washer (11). Discard lock washer.
- (4) Remove bolt (12), lock washer (13), flat washer (14), and motor starter (5). Discard lock washer.

d. Installation.

- (1) Install three new thermal overload heaters (6) onto new motor starter (5).

NOTE

Steps 2 through 4 apply only to new motor starter. A new motor starter is configured with jumpers connected for operation at 115 Vac and must be reconnected for use with 208/230 Vac.

- (2) Remove two red wire lead jumpers between terminals L2 to 96 and A1 to 3. Discard jumpers.
- (3) Move red wire lead jumper from between terminals A2 to 95 and place between terminals A1 to 95.
- (4) Set overload adjustment (FLA) dial to A position and (RESET) adjustment dial to M position.
- (5) Install motor starter (5), flat washer (14), new lock washer (13), and bolt (12).
- (6) Install flat washer (11), new lock washer (10), and screw (9).
- (7) Using tags and wiring diagram (fig. 1-4), install wire leads (8). Remove tags.
- (8) Close control box cover (3). Install two new lock washers (2) and bolts (1).

NOTE

FOLLOW-ON MAINTENANCE:
Close control panel cover.
Connect power and put unit back into service.

c. Installation.

- (1) Install contactor (5), four flat washers (9), new lock washers (8), and bolts (7).
- (2) Using tags and wiring diagram (fig. 1-4), install wire leads (6). Remove tags.
- (3) Close control box cover (3). Install two new lock washers (2) and bolts (1).

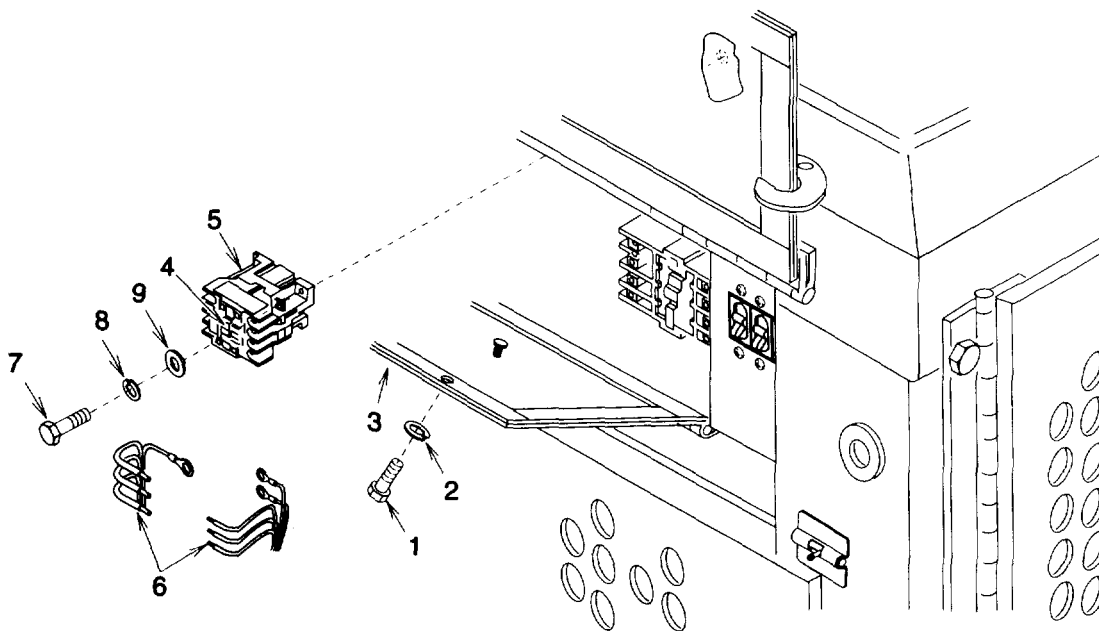


Figure 4-20. Contactor

NOTE

FOLLOW-ON MAINTENANCE:
 Close control panel cover.
 Connect power and put unit back into service.

- (3) Remove bolt (8), lock washer (9), flat washer (10), and control relay (4). Discard lock washer.

c. Installation.

NOTE

The following procedures apply to both control relays K3 and K4. Quantities given are for each relay.

- (1) Install control relay (4), flat washer (10), new lock washer (9), and bolt (8).
- (2) If wire lead (5) terminals were damaged, repair per paragraph 4-20.
- (3) If sleeving insulation (6) is damaged or was removed, replace it.
 - (a) Using tags and wiring diagram (fig. 1-4), connect wire leads (5) to faston tab adapter (7).
 - (b) Place sleeving insulation (6) over faston tab adapter (7) and wire lead (5) terminals.
 - (c) Shrink sleeving insulation (6) in place using heat gun.
- (4) Using tags and wiring diagram (fig. 1-4), install wire leads (5). Remove tags.
- (5) Close control box cover (3). Install two new lock washers (2) and bolts (1).

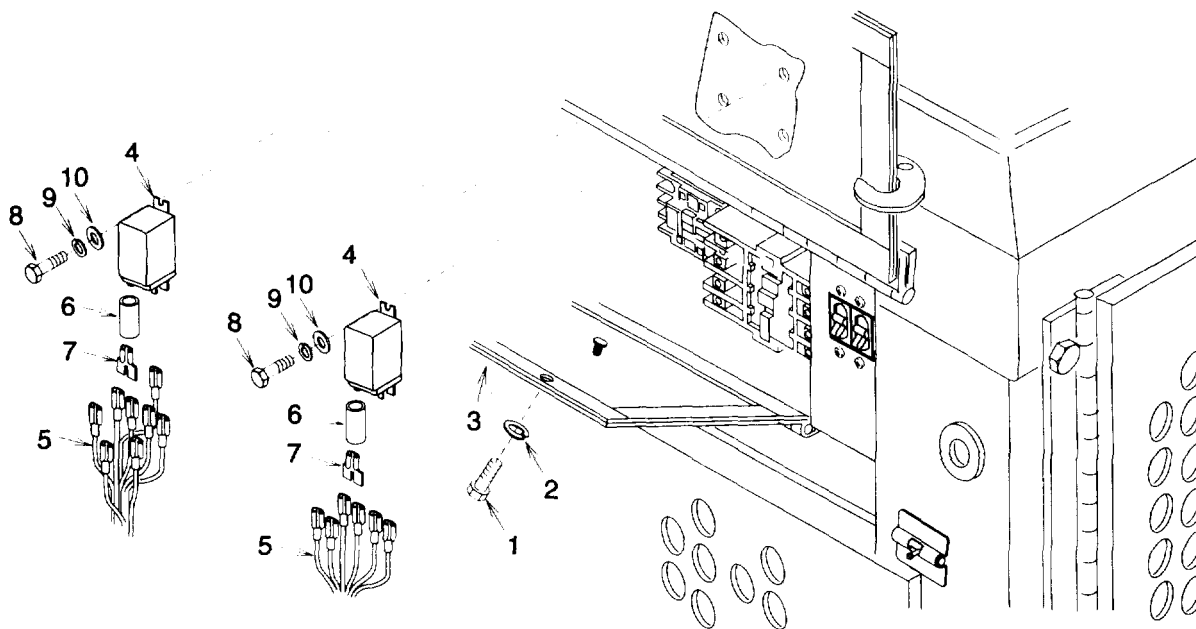


Figure 4-21. Control Relays

NOTE

FOLLOW-ON MAINTENANCE:
 Close control panel cover.
 Connect power and put unit back into service.

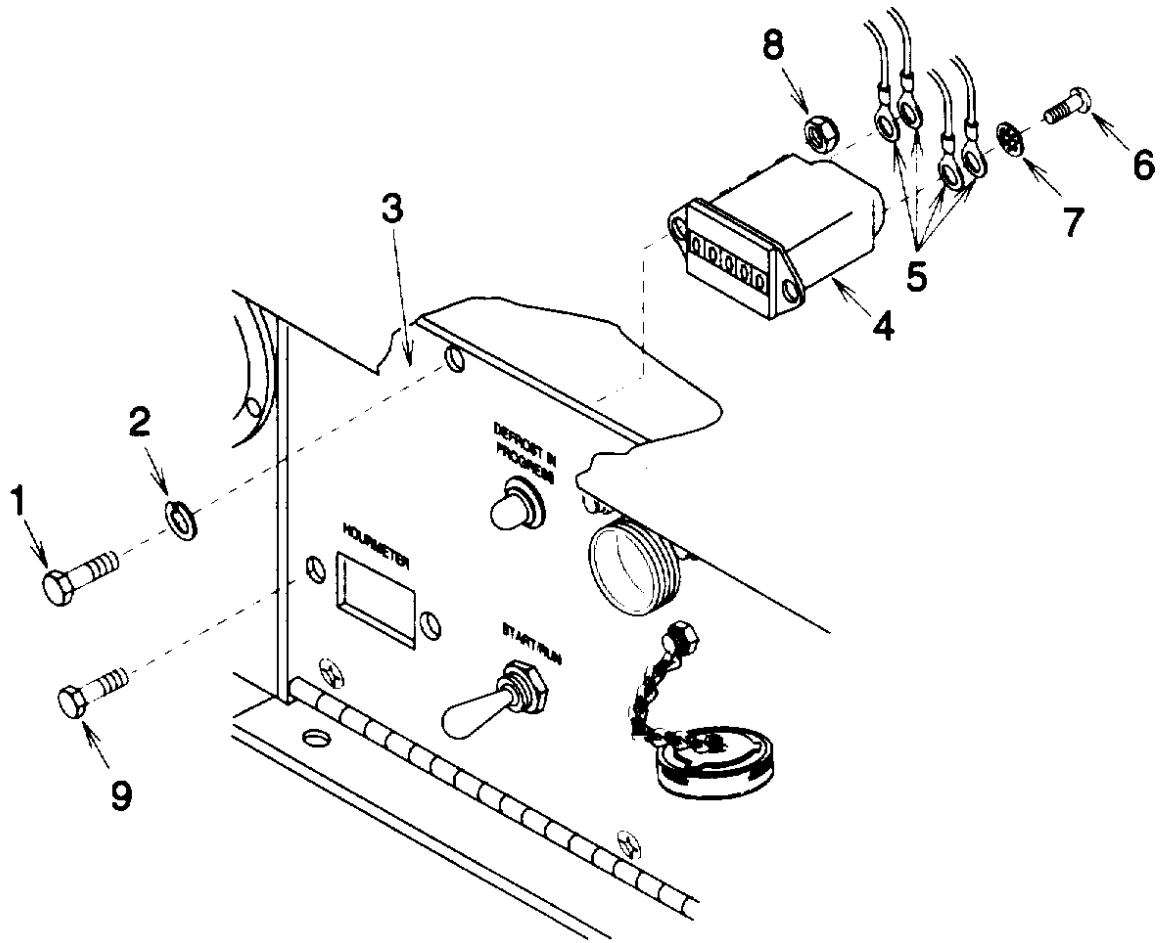


Figure 4-22. Hourmeter

NOTE

FOLLOW-ON MAINTENANCE:
 Close control panel cover.
 Connect power and put unit back into service.

4-28. TOGGLE SWITCH S1 TESTING AND REPLACEMENT.Equipment Conditions:

Refrigeration unit shut down (para 2-7) and power disconnected.

Control panel cover open.

Materials/Parts:

Lock Washers (2)
1, Appendix G
Marker tags (2)
7, Appendix E

General Safety Instructions:**WARNING**

High voltage and exposed rotating parts are used in the refrigeration unit. Personal injury can result if power is connected.

a. Testing. (See Figure 1-4.)

- (1) Be sure power has been disconnected at the source and remove two bolts (1) and lock washers (2). Open control box cover (3). Discard lock washers.
- (2) Using multimeter set to measure continuity, check toggle switch (4) continuity between terminals 2 to 3 with toggle switch in both START/RUN and OFF position. Continuity should be indicated only when toggle switch (4) is in the START/RUN position. If continuity was indicated in the OFF position or if no continuity was indicated in the START/RUN position, replace toggle switch (4).
- (3) If no failure was indicated, close control box cover (3) and install two new lock washers (2) and bolts (1).

b. Removal.

- (1) Be sure power has been disconnected at the source and remove two bolts (1) and lock washers (2). Open control box cover (3). Discard lock washers.

NOTE

Terminal and mounting hardware is supplied with toggle switch.

- (2) Tag wire leads (5) and remove two screws (6), lock washers (7), and wire leads.
- (3) Remove nut (8), lock washer (9), retainer (10), and toggle switch (4).

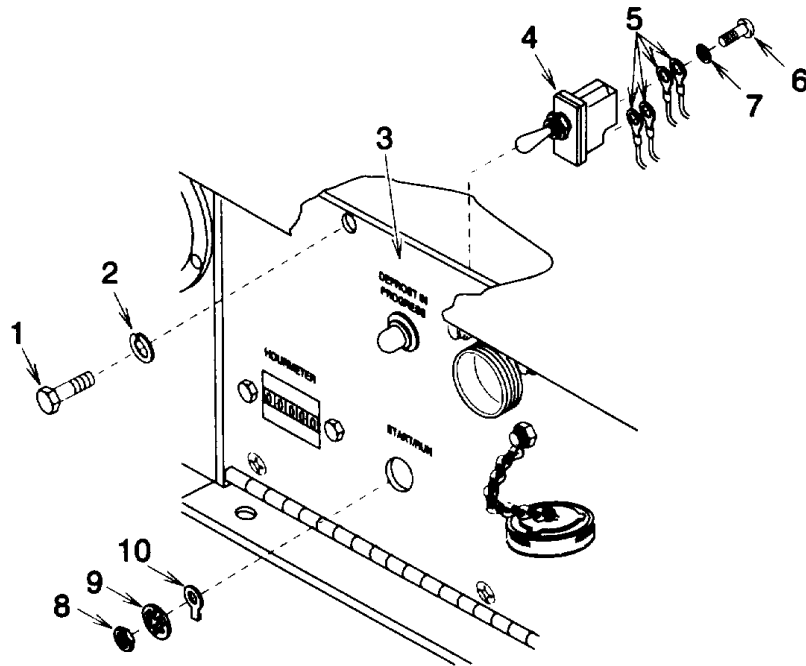


Figure 4-23. Toggle Switch

c. Installation.

- (1) Install toggle switch (4), retainer (10), lock washer (9), and nut (8).
- (2) Using tags and wiring diagram (fig. 1-4), install wire leads (5), two lock washers (7), and screws (6). Remove tags.
- (3) Close control box cover (3). Install two new lock washers (2) and bolts (1).

NOTE

FOLLOW-ON MAINTENANCE:
Close control panel cover.
Connect power and put unit back into service.

4-29. REPEAT CYCLE TIMER TM1 TESTING AND REPLACEMENT.

This task covers:	a. Testing	b. Removal	c. Installation
--------------------------	-------------------	-------------------	------------------------

INITIAL SETUP

Materials/Parts:

Lock Washers (2)
 1, Appendix G
 Self Locking Nut (2)
 8, Appendix G
 Tie Down Strap
 9, Appendix G
 Marker tags (7)
 7, Appendix E

Equipment Conditions:

Refrigeration unit shut down (para 2-7) and power disconnected.
 Control panel cover open.

General Safety Instructions:

WARNING

High voltage and exposed rotating parts are used in the refrigeration unit. Personal injury can result if power is connected.

a. Testing. (See Figure 1-4.)

- (1) Be sure power has been disconnected at the source and remove two bolts (1) and lock washers (2). Open control box cover (3). Discard lock washers.
- (2) Remove and discard tie down strap (4).
- (3) Pull repeat cycle timer (5) from relay mounting socket (6).
- (4) Using multimeter set to measure continuity, check repeat cycle timer (5) continuity between terminals 1 to 7. Continuity should be indicated. If no continuity was indicated, replace repeat cycle timer.
- (5) Using multimeter set to measure continuity, check repeat cycle timer (5) continuity between terminals 4 to 7 and 6 to 9. No continuity should be indicated. If continuity was indicated, replace repeat cycle timer.
- (6) If relay mounting socket (6) is damaged, replace it.
- (7) If no failure was indicated, push repeat cycle timer (5) into relay mount socket (6) and install new tie down strap (4).
- (8) If no failure was indicated, close control box cover (3) and install two new lock washers (2) and bolts (1).

b. Removal.

- (1) Be sure power has been disconnected at the source and remove two bolts (1) and lock washers (2). Open control box cover (3). Discard lock washers.
- (2) Remove and discard tie down strap (4).
- (3) Pull repeat cycle timer (5) from relay mounting socket (6).

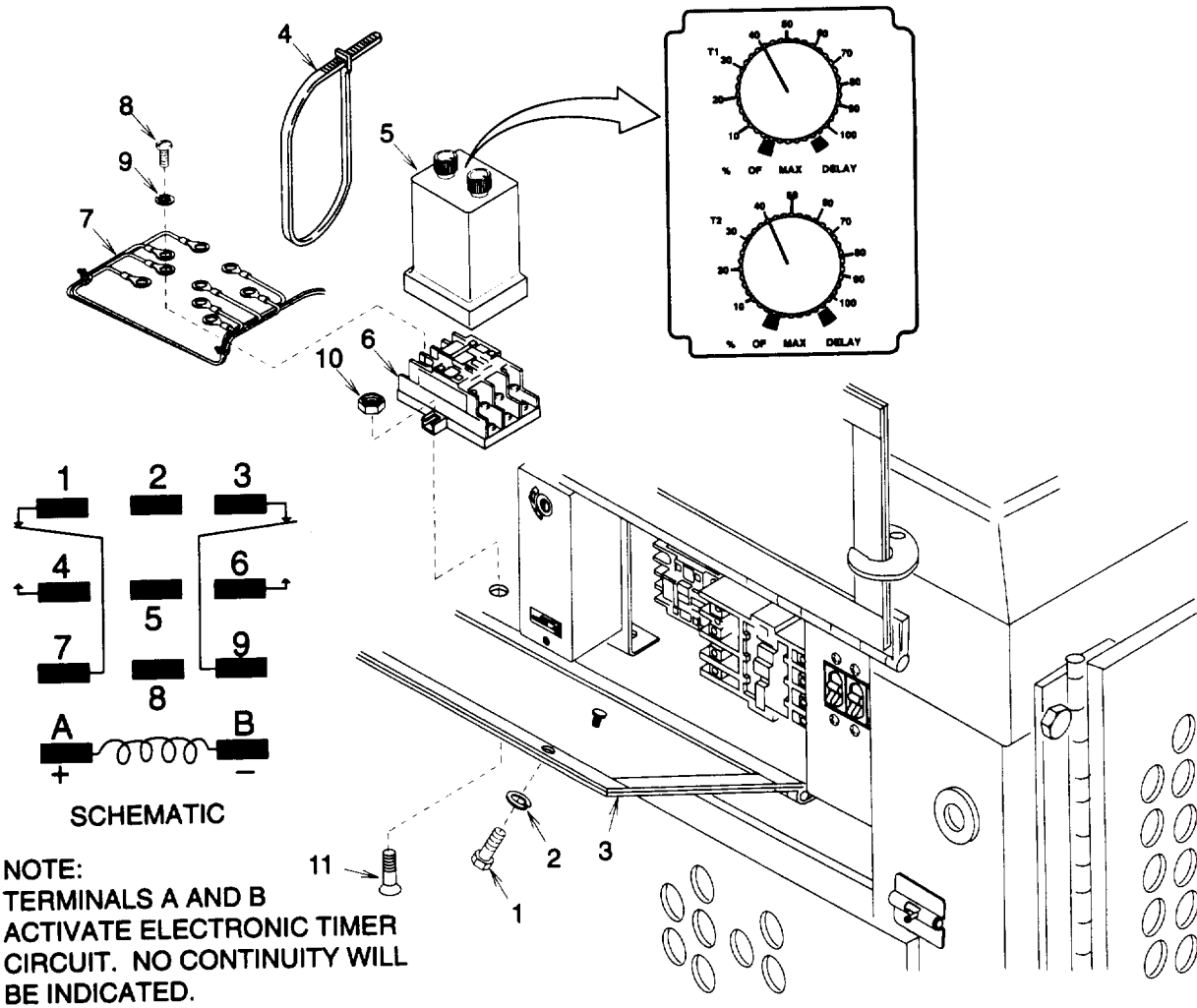


Figure 4-24. Repeat Cycle Timer

4-29. REPEAT CYCLE TIMER TM1 TESTING AND REPLACEMENT. - Continued**NOTE**

Terminal hardware is supplied with repeat cycle timer.

- (4) Tag wire lead terminals (7) and remove seven screws (8), lock washers (9), and wire lead terminals.
- (5) Remove two self locking nuts (10), screws (11), and relay mounting socket (6). Discard self locking nuts.

c. Installation.

- (1) Install relay mounting socket (6), two screws (11), and new self locking nuts (10).
- (2) Using tags and wiring diagram (fig. 1-4), install wire lead terminals (7), seven lock washers (9), and screws (8). Remove tags.
- (3) Push repeat cycle timer (5) into relay mount socket (6) and install new tie down strap (4).
- (4) Adjust controls (para 4-8) as necessary.
- (5) Close control box cover (3) and install two new lock washers (2) and bolts (1).

NOTE

FOLLOW-ON MAINTENANCE:
Close control panel cover.
Connect power and put unit back into service.

4-30. REMOTE BULB THERMOSTAT S3 TESTING AND REPLACEMENT.

This task covers:	a. Testing	b. Removal	c. Installation
--------------------------	-------------------	-------------------	------------------------

INITIAL SETUP**Materials/Parts:**

Lock Washers (2)
1, Appendix G
Self Locking Nuts (4) (Thermostat)
8, Appendix G
Self Locking Nuts (2) (Bracket)
8, Appendix G
Self Locking Nuts (2)
11, Appendix G
Self Locking Nut
12, Appendix G
Tie Down Straps
10, Appendix G
Marker tags (2)
7, Appendix E
Silicone RTV
20, Appendix E

Equipment Conditions:

Refrigeration unit shut down (para 2-7) and power disconnected.
Control panel cover open.
Left side condenser door open.
Evaporator coil guard removed (para 4-18).
Evaporator air outlet guard removed (para 4-17).

General Safety Instructions:**WARNING**

High voltage and exposed rotating parts are used in the refrigeration unit. Personal injury can result if power is connected.

a. Testing. (See Figure 1-4.)

- (1) Be sure power has been disconnected at the source and remove two bolts (1) and lock washers (2). Open control box cover (3). Discard lock washers.
- (2) Remove screw (4) and cover (5).
- (3) Remove two self locking nuts (6), bolts (7), and sensing bulb bracket (8). Discard self locking nuts.
- (4) Remove self locking nut (9), bolt (10), and sensing bulb bracket (8). Discard self locking nut.
- (5) Remove clamp (11).
- (6) Immerse sensing bulb (12) into a temperature controlled bath at 32° F. A bath at this temperature can be made by putting the sensing bulb into a container of ice and covering with water. Ice must remain packed around sensing bulb at all times during test.
- (7) Using multimeter set to measure continuity, check remote bulb thermostat (13) continuity between terminals 1 and 3 with thermostat setting at 24° F and at 40° F. Continuity should be indicated only when the setting is at 240 F. If continuity was indicated at 400 F setting, replace thermostat.
- (8) If test did not indicate a failure, slip clamp (11) over sensing bulb (12).
- (9) Install clamps (11) and (14), bolt (10), and new self locking nut (9).
- (10) Install sensing bulb bracket (8), two bolts (7), and new self locking nuts (6).

4-30. REMOTE BULB THERMOSTAT S3 TESTING AND REPLACEMENT. - Continued

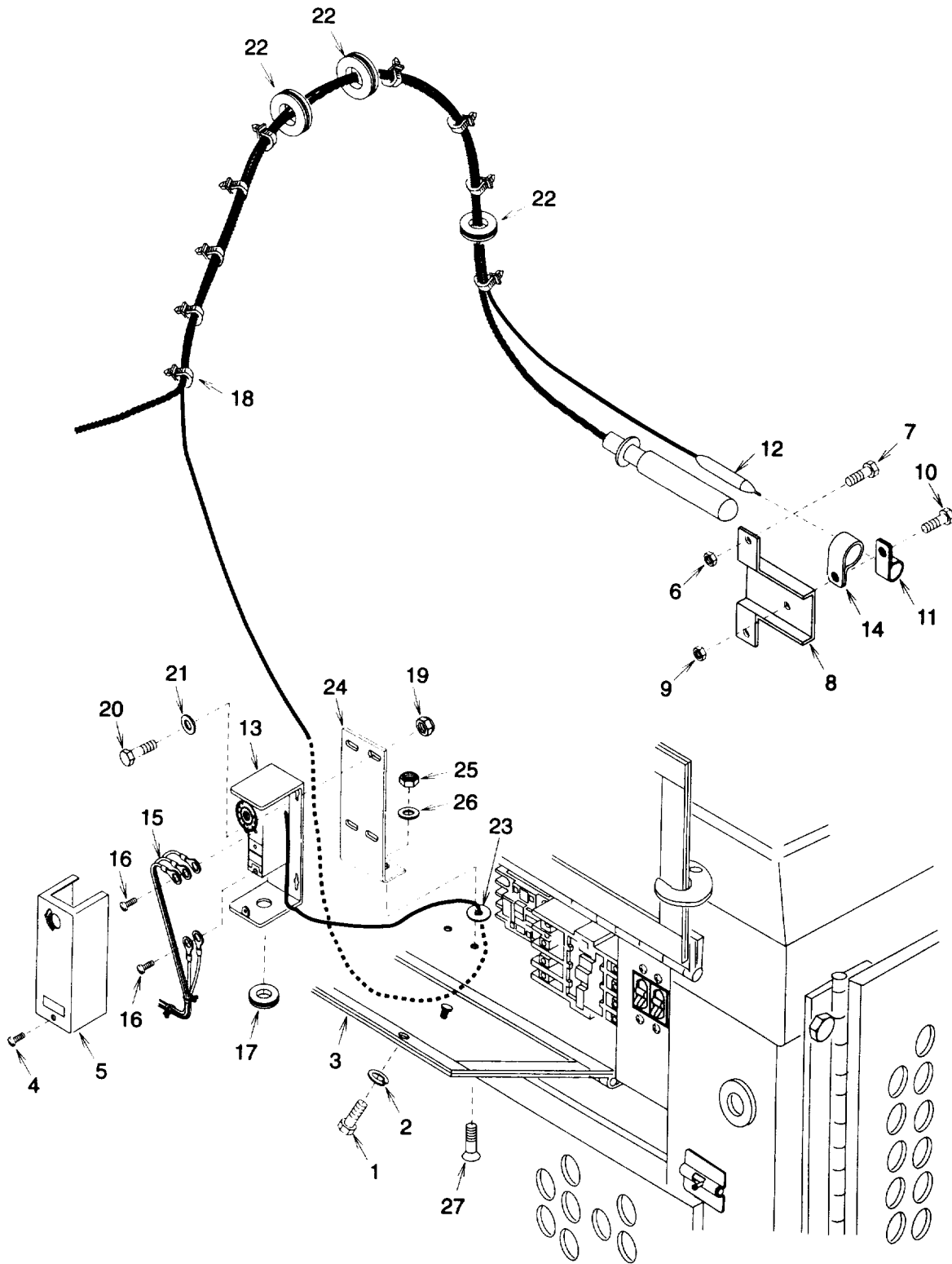


Figure 4-25. Remote Bulb Thermostat (Temperature Control)

- (11) Install cover (5) and screw (4).
- (12) Close control box cover (3) and install two new lock washers (2) and bolts (1).

b. Removal.

- (1) Be sure power has been disconnected at the source and remove two bolts (1) and lock washers (2). Open control box cover (3). Discard lock washers.
- (2) Remove screw (4) and cover (5).
- (3) Remove two self locking nuts (6), bolts (7), and sensing bulb bracket (8). Discard self locking nuts.
- (4) Remove self locking nut (9), bolt (10), and sensing bulb bracket (8). Discard self locking nut.
- (5) Remove clamp (11).
- (6) Tag wire leads (15) then remove two screws (16) and wire leads.
- (7) Pull wire leads (15) from remote bulb thermostat (13) and remove grommet (17).
- (8) Remove tie down straps (18).
- (9) Remove four self locking nuts (19), bolts (20), and flat washers (21). Discard self locking nuts.
- (10) Remove remote bulb thermostat (13) and any grommets (22) and (23) necessary to remove sensing bulb (12).
- (11) If temperature control switch bracket (24) is damaged, remove two self locking nuts (25), flat washers (26), screws (27), and bracket. Discard self locking nuts.
- (12) Remove any silicone RTV remaining in evaporator frame grommets (22).

c. Installation.

- (1) If removed, install temperature control bracket (24), two screws (27), flat washers (26), and new self locking nuts (25).
- (2) Install remote bulb thermostat (13) routing sensing bulb (12) through grommets (22) and (23). Install any grommets removed.
- (3) Install remote bulb thermostat (13), four flat washers (21), bolts (20), and new self locking nuts (19).
- (4) Install tie down straps (18) as necessary.
- (5) Install grommet (17) and push wire leads (15) into remote bulb thermostat (13).
- (6) Using tags and wiring diagram (fig. 1-4), install wire leads (15) and two screws (16). Remove tags.
- (7) Slip clamp (11) over sensing bulb (12).
- (8) Install clamps (11) and (14), bolt (10), and new self locking nut (9).
- (9) Install sensing bulb bracket (8), two bolts (7), and new self locking nuts (6).

4-30. REMOTE BULB THERMOSTAT S3 TESTING AND REPLACEMENT. - Continued

- (10) Install cover (5) and screw (4).
- (11) Close control box cover (3) and install two new lock washers (2) and bolts (1).
- (12) Apply silicone RTV into evaporator frame grommets (22) to seal evaporator enclosure.

NOTE

FOLLOW-ON MAINTENANCE:
Close control panel cover.
Close left side condenser door.
Install evaporator air outlet guard (para 4-17).
Install evaporator coil guard (para 4-18).
Connect power and put unit back into service.

4-31. THERMOMETER TESTING AND REPLACEMENT. - Continued

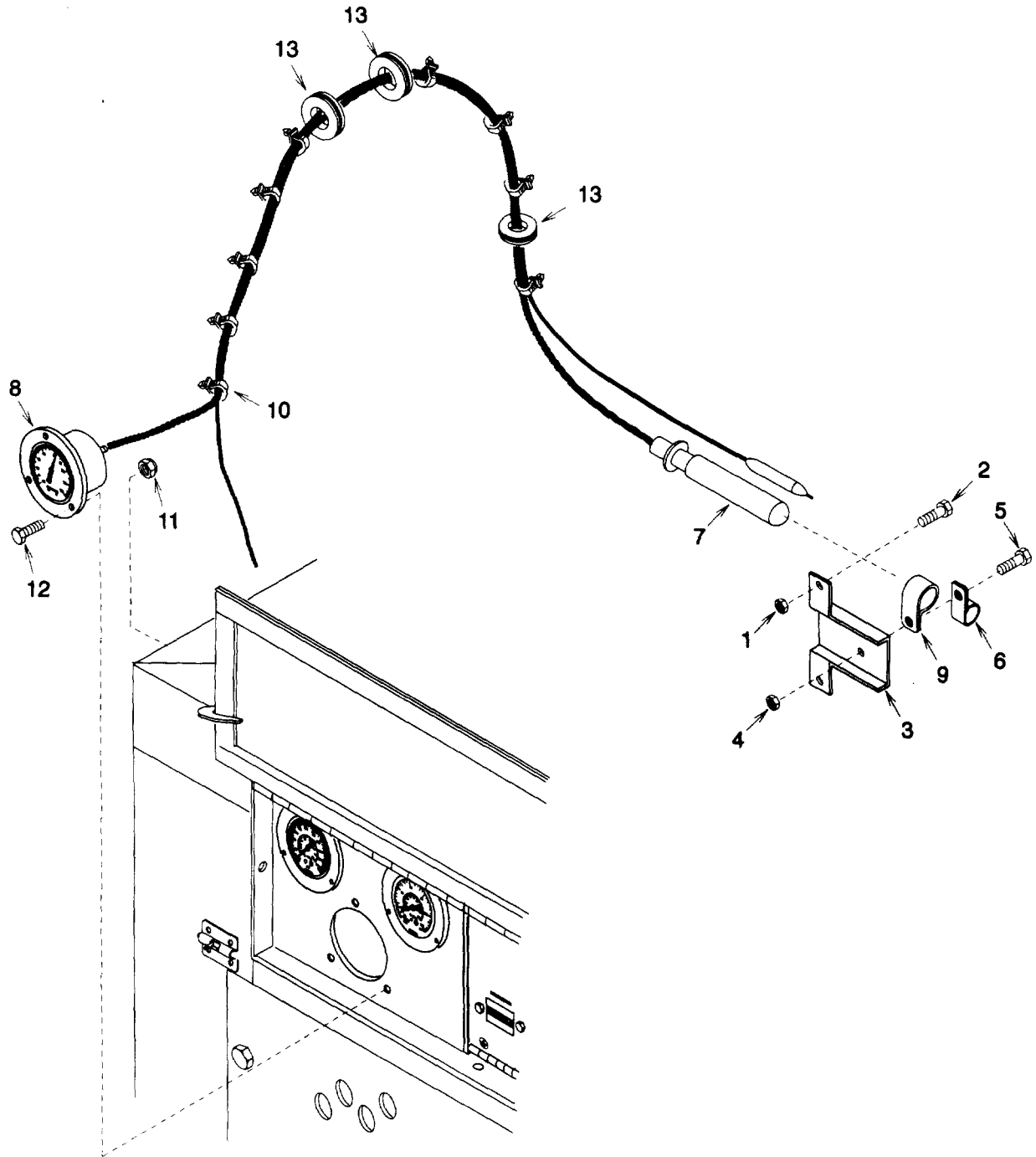


Figure 4-26. Refrigeration

b. Removal.

- (1) Be sure power has been disconnected at the source and remove two self locking nuts (1), bolts (2), and sensing bulb bracket (3). Discard self locking nuts.
- (2) Remove self locking nut (4), bolt (5), and sensing bulb clamp (6). Discard self locking nut.
- (3) Remove clamp (6) from sensing bulb (7).
- (4) Remove tie down straps (10).
- (5) Remove three self locking nuts (11) and bolts (12). Discard self locking nuts.
- (6) Remove thermometer (8) and any grommets (13) necessary to remove sensing bulb (7).
- (7) Remove any silicone RTV remaining in evaporator frame grommets (13).

c. Installation.

- (1) Install thermometer (8) routing sensing bulb (7) through grommets (13). Install any grommets removed.
- (2) Install thermometer (8), three bolts (12), and new self locking nuts (11).
- (3) Install tie down straps (10) as necessary.
- (4) Slip clamp (6) over sensing bulb (7).
- (5) Install clamps (6) and (9), bolt (5), and new self locking nut (4).
- (6) Install sensing bulb bracket (3), two bolts (2), and new self locking nuts (1).
- (7) Apply silicone RTV into evaporator frame grommets (13) to seal evaporator enclosure.

NOTE

FOLLOW-ON MAINTENANCE:
Close control panel cover.
Close left side condenser door.
Install evaporator coil guard (para 4-18).
Install evaporator air outlet guard (para 4-17).
Connect power and put unit back into service

b. Removal.

- (1) Remove insulation as necessary to expose defrost temperature switch (1).
- (2) Be sure power has been disconnected at the source then tag and disconnect two tabs (2).
- (3) Loosen two nuts (3), slide clamps (4) as necessary and remove defrost temperature switch (1).

c. Installation.

- (1) Install defrost temperature switch (1), slide two clamps (4) over switch, and tighten nuts (3).
- (2) Install new tab housing (5) and tab (2) onto each defrost temperature switch (1) wire lead (para 4-20).
- (3) Using tags and wiring diagram (fig. 1-4), connect tabs (2). Remove tags.
- (4) Install any insulation that was removed and wrap with insulation tape as necessary.

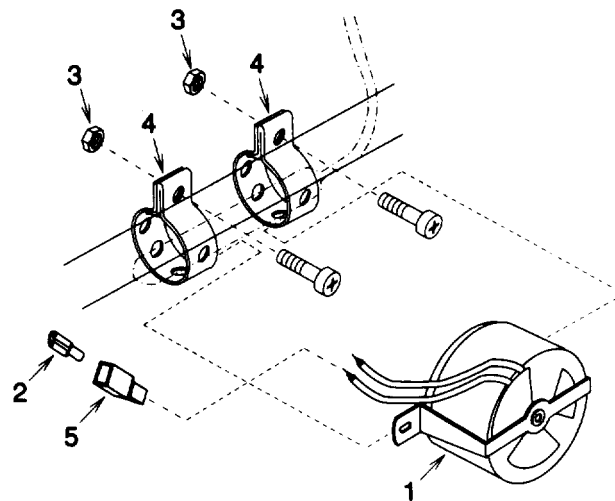


Figure 4-27. Defrost Temperature Switch

NOTE

FOLLOW-ON MAINTENANCE:
Install evaporator coil guard (para 4-18).
Connect power and put unit back into service.

4-33. POWER DISTRIBUTION BLOCK TB2 TESTING AND REPLACEMENT.

This task covers: a. Testing b. Removal c. Installation

INITIAL SETUP**Equipment Conditions:**

Refrigeration unit shut down (para 2-7) and power disconnected.

Right side condenser door open.

Enclosure assembly door open.

Materials/Parts:

Lock Washers (4)

13, Appendix G

Self Locking Nuts (4)

14, Appendix G

Marker tags (9)

7, Appendix E

General Safety Instructions:**WARNING**

High voltage and exposed rotating parts are used in the refrigeration unit. Personal injury can result if power is connected.

a. Testing. Be sure power has been disconnected at the source, then using multimeter set to measure continuity, check power distribution block (1) continuity between each terminal A, B, C, and N to ground. No continuity should be indicated. If continuity was indicated, replace distribution block.

b. Removal.

NOTE

Ground wire terminal hardware is supplied with enclosure assembly.

(1) Be sure power has been disconnected at the source then tag and disconnect wire leads (2). Remove bolt (3), lock washer (4), and wire leads.

(2) If enclosure assembly (5) must be replaced, pull wire leads (2) out through strain relief cable bushings (6).

(3) Remove two conduit lock nuts (7) and strain relief cable bushings (6)..

(4) Remove four bolts (8), lock washers (9), and flat washers (10).

(5) Remove four self locking nuts (11), screws (12), and power distribution block (1). Discard self locking nuts.

c. Installation.

(1) Install power distribution block (1), four screws (12), and new self locking nuts (11).

(2) If enclosure assembly (5) was removed, install enclosure assembly, four flat washers (10), new lock washers (9), and bolts (8).

(3) Install two strain relief cable bushings (6) and conduit lock nuts (7).

- (4) Push wire leads (2) through stain relief cable bushings (6).
- (5) Using tags and wiring diagram (fig. 1-4), connect wire leads (2). Install wire leads, lock washer (4), and bolt (3). Remove tags.

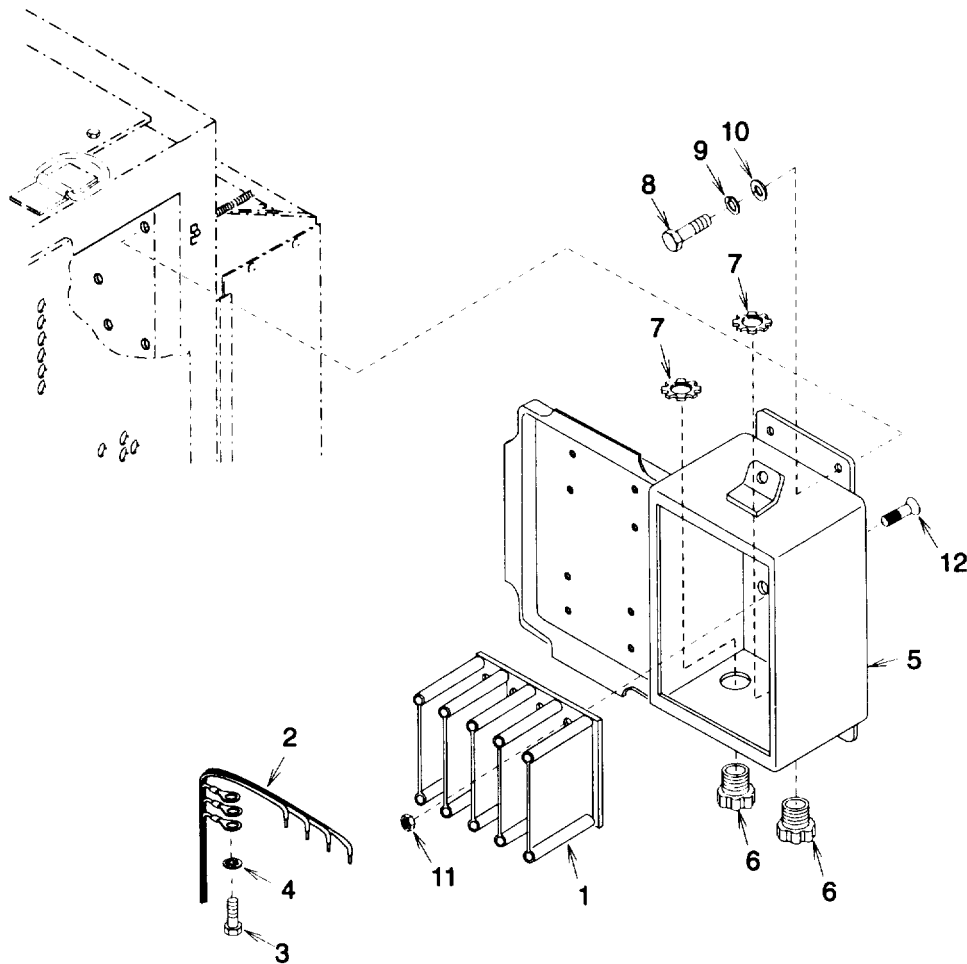


Figure 4-28. Power Distribution Block
NOTE

FOLLOW-ON MAINTENANCE:
 Close enclosure assembly door.
 Close right side condenser door.
 Connect power and put unit back into service.

4-34. PUSH SWITCHES S6 AND S7 TESTING AND REPLACEMENT.

This task covers: a. Testing b. Removal c. Installation

INITIAL SETUP

Tools:

Heat Gun

4, Section III, Appendix B

Materials/Parts:

Self Locking Nuts (2 Each Push Switch)

8, Appendix G

Sleeving Insulation (1 Each Push Switch)

2, Figure 5-19, Appendix F

Sleeving Insulation (1 Each Push Switch)

3, Figure 5-19, Appendix F

Marker tags (4)

7, Appendix E

Equipment Conditions:

Refrigeration unit shut down (para 2-7) and power disconnected.

Both side condenser doors open.

General Safety Instructions:

WARNING

High voltage and exposed rotating parts are used in the refrigeration unit. Personal injury can result if power is connected

a. Testing.

(1) Remove sleeving insulation (1).

(2) Tag and disconnect wire leads (2).

(3) Using multimeter set to measure continuity, check push switch (3) contact continuity across terminals C and NO with the push button switch out and pushed in. Continuity should only be indicated with the switch pushed in. If continuity was not indicated when switch was pushed in or was indicated with switch out, replace push switch.

NOTE

Smaller diameter sleeving insulation must go over wire lead connecting to push switch terminal C.

(4) If test did not indicate a failure, install insulation sleeving (1) over wire leads (2).

(5) Using tags and wiring diagram (fig. 1-4), connect wire leads (2). Remove tags.

NOTE

Sleeving insulation covers only terminal C on one side of push switch, but must cover both terminals NO and NC on the other side.

(6) Slip sleeving insulation (1) over exposed terminals and shrink in place using heat gun.

b. Removal.

(1) Remove sleeving insulation (1).

- (2) Tag and disconnect wire leads (2).
- (3) Remove two self locking nuts (4), flat washers (5), bolts (6), and push switch (3). Discard self locking nuts.

c. Installation.

- (1) Install push switch (3), two bolts (6), flat washers (5), and new self locking nuts (4).

NOTE

Smaller diameter sleeving insulation must go over wire lead connecting to push switch terminal C.

- (2) Install insulation sleeving (1) over wire leads (2).
- (3) Using tags and wiring diagram (fig. 1-4), connect wire leads (2). Remove tags.

NOTE

Sleeving insulation covers only terminal C on one side of push switch, but must cover both terminals NO and NC on the other side.

- (4) Slip sleeving insulation (1) over exposed terminals and shrink in place using heat gun.

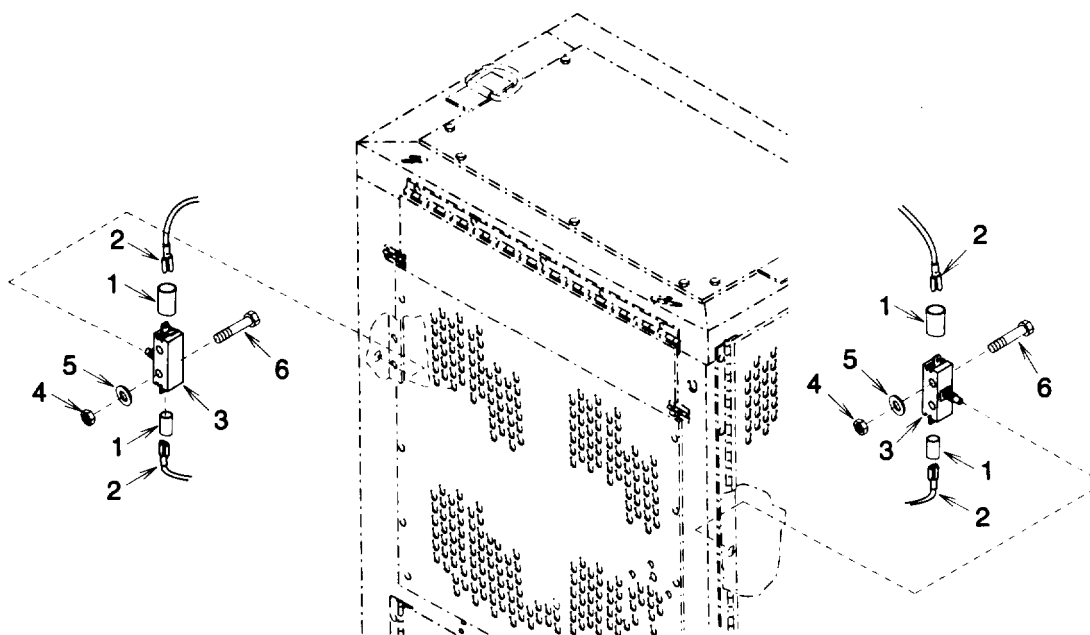


Figure 4-29. Push (Door Switches

NOTE

**FOLLOW-ON MAINTENANCE:
Close both side condenser doors.
Connect power and put unit back into service.**

4-35. AC MOTOR B2 TESTING AND REPLACEMENT.

This task covers: a. Testing b. Removal c. Installation

INITIAL SETUP**Materials / Parts:**

Lock Washers (12)
7, Appendix G
Self Locking Nuts (4)
5, Appendix G
Marker tags (4)
7, Appendix E

Equipment Conditions:

Refrigeration unit shut down (para 2-7) and power disconnected.
Left side condenser door open.

General Safety Instructions:**WARNING**

High voltage and exposed rotating parts are used in the refrigeration unit. Personal injury can result if power is connected.

a. Testing. (See Figure 1-4.)

- (1) Remove four bolts (1) and terminal cover (2).
- (2) Tag and disconnect wire leads (3).
- (3) Using multimeter set to measure continuity, check AC motor (4) winding continuity between leads T1 to T2, T1 to T3, and T3 to T2. Continuity should be indicated. If continuity was not indicated, replace motor.
- (4) Using multimeter set to measure continuity, check AC motor (4) winding continuity between each lead T1, T2, and T3 to motor frame ground. No continuity should be indicated. If continuity was indicated, replace motor.
- (5) If no failure was indicated, connect wire leads (2) using tags and wiring diagram (fig. 1-4). Remove tags.
- (6) Install terminal cover (2) and four bolts (1).

b. Removal.

- (1) Remove four bolts (1) and terminal cover (2).
- (2) Tag and disconnect wire leads (3).
- (3) Remove conduit locknut (5), strain relief cable bushing (6), and wire leads (3).
- (4) Remove four self locking nuts (7) and flat washers (8). Discard self locking nuts.
- (5) Slip V belt (9) off pulley (10) and remove AC motor (4).
- (6) Loosen set screw (11) and remove pulley (10) and key (12).

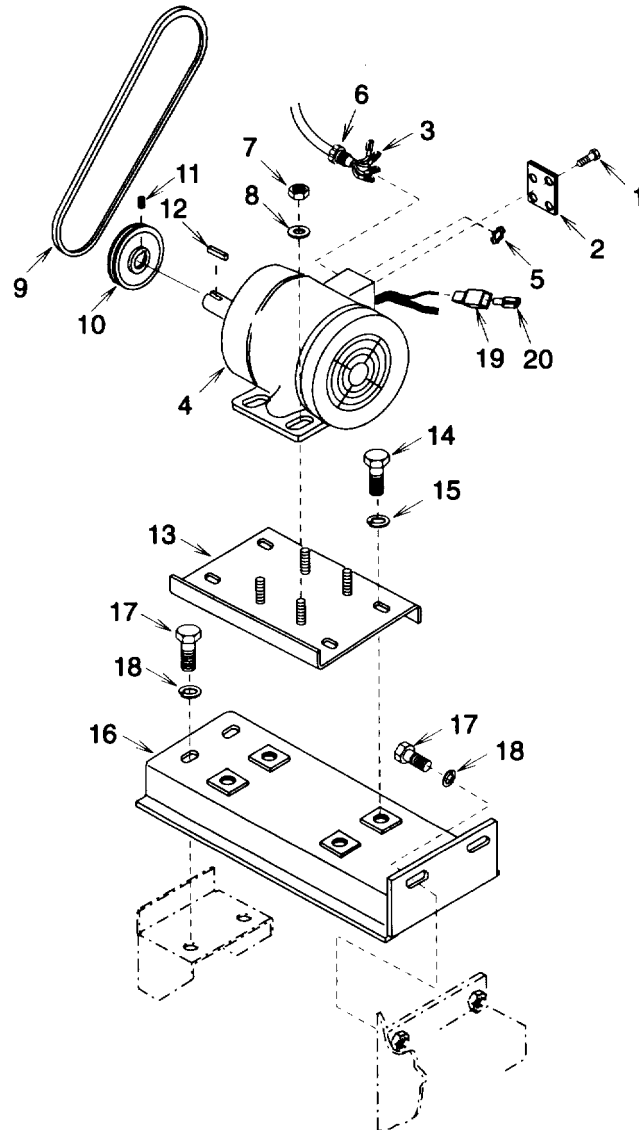


Figure 4-30. AC Motor

4-35. AC MOTOR B2 TESTING AND REPLACEMENT. - Continued

- (7) If adjusting-motor mount bracket (13) must be replaced, remove four bolts (14), lock washers (15), and bracket. Discard lock washers.
- (8) If motor mount bracket (16) must be replaced, remove four bolts (17), lock washers (18), and bracket. Discard lock washers.

c. Installation.

- (1) If motor mount bracket (16) was removed, install bracket, four new lock washers (18), and bolts (17).
- (2) If adjusting-motor mount bracket (13) was removed, install bracket, four new lock washers (15), and bolts (14).
- (3) Install new tab housing (19) and tab (20) onto each AC motor (4) wire lead (para 4-20).
- (4) Install key (12) and pulley (10). Tighten set screw (11).
- (5) Install AC motor (4) and slip V belt (9) onto pulley (10).
- (6) Install four flat washers (8) and new self locking nuts (7).
- (7) Adjust belt tension and alignment per paragraph 4-36.
- (8) Install wire leads (3), strain relief cable bushing (6), and conduit locknut (5).
- (9) Using tags and wiring diagram (fig. 1-4), connect wire leads (3).
- (10) Install terminal cover (2) and four bolts (1).

NOTE

**FOLLOW-ON MAINTENANCE:
Close left side condenser door.
Connect power and put unit back into service.**

4-36. V BELT REPLACEMENT AND ADJUSTMENT.

This task covers: a. Removal b. Installation c. Adjustment

INITIAL SETUP**Equipment Conditions:**

Refrigeration unit shut down (para 2-7) and power disconnected.

Left side condenser door open.

Materials/Parts:

Lock Washers (8)
13, Appendix G

General Safety Instructions:**WARNING**

High voltage and exposed rotating parts are used in the refrigeration unit. Personal injury can result if power is connected

a. Removal.

- (1) Loosen four self locking nuts (1) and four bolts (2).
- (2) Slide AC motor (3) and motor mount bracket (4) as necessary to slip V belt (5) off pulley (6).
- (3) Remove eight bolts (7) and lock washers (8). Discard lock washers.

CAUTION

Moving the fan drive shaft too far can cause damage to the evaporator fan or coil.

- (4) Loosen two set screws (9) and carefully move fan drive shaft (10) just enough to work V belt (5) around support (11) and condenser fan (12).

b. Installation.

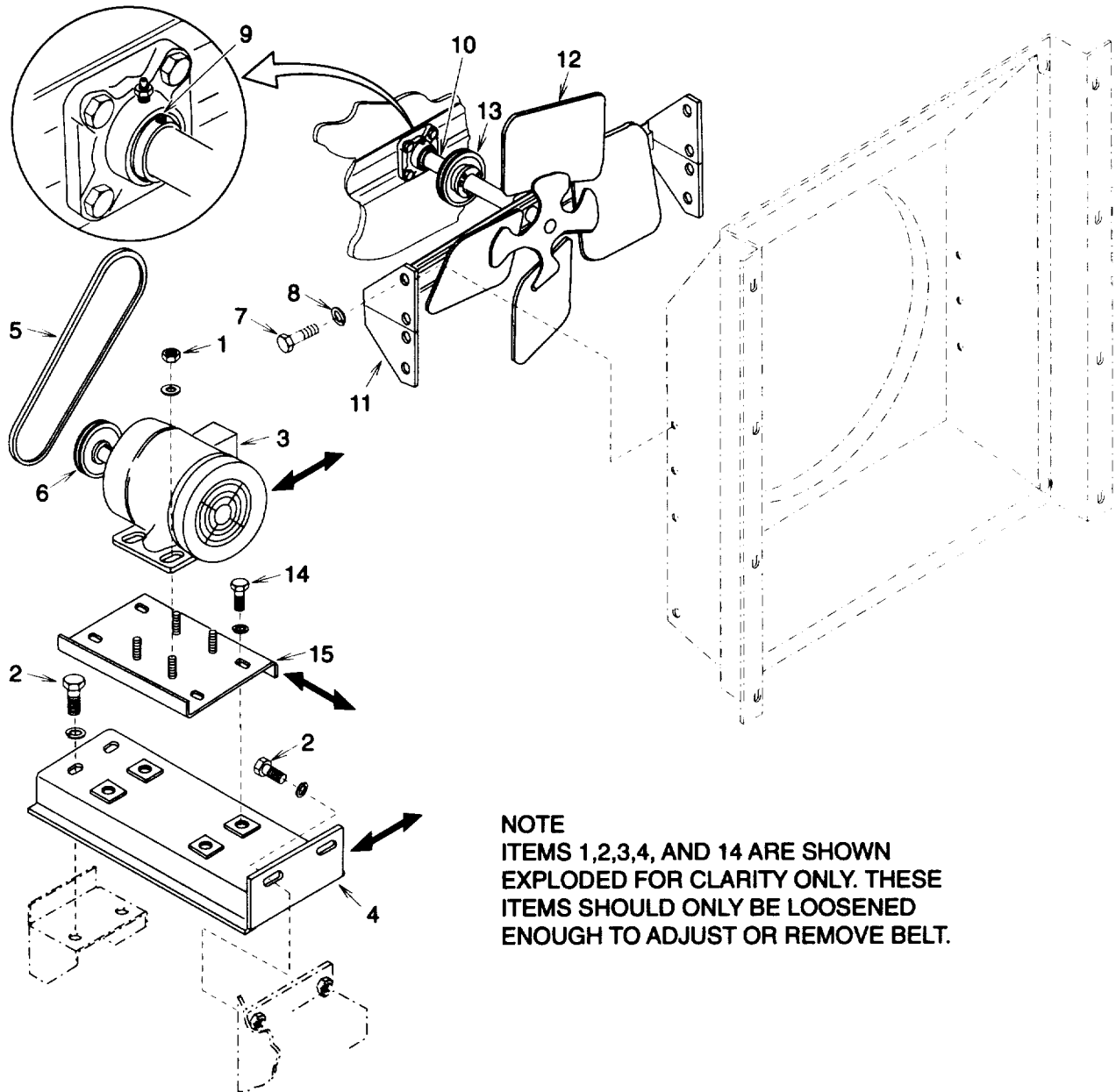
- (1) Work V belt around support (11) and condenser fan (12).
- (2) Move fan drive shaft (10) to align support (11) mounting holes and install eight new lock washers (8) and bolts (7). Tighten two set screws (9) against flat surfaces on shaft.
- (3) Slip V belt (5) over sheave (13) and pulley (6).
- (4) Tighten four bolts (2) and four self locking nuts (1).

c. Adjustment.

- (1) Loosen four bolts (14) and move adjusting-motor mount bracket (15) to align pulley (6) and sheave (13). When pulley and sheave are aligned, tighten four bolts.
- (2) Loosen four self locking nuts (1) and four bolts (2).

4-36. **V BELT T REPLACEMENT AND ADJUSTMENT.** - Continued

- (3) Pull AC motor (3) and motor mount bracket (4) to set V belt (5) tension. Belt tension is correct when 4 lb (2 kg) force is applied to the mid point of the belt and it deflects 3/8 in. (1 cm). When the correct tension is reached, tighten four bolts (2) and four self locking nuts (1).



NOTE
 ITEMS 1,2,3,4, AND 14 ARE SHOWN
 EXPLODED FOR CLARITY ONLY. THESE
 ITEMS SHOULD ONLY BE LOOSENED
 ENOUGH TO ADJUST OR REMOVE BELT.

Figure 4-31. V Belt

NOTE

FOLLOW-ON MAINTENANCE:
 Close left side condenser door.
 Connect power and put unit back into service.

4-37. CONDENSER FAN REPLACEMENT.

This task covers: a. Removal c. Installation

INITIAL SETUP**Equipment Conditions:**

Refrigeration unit shut down (para 2-7) and power disconnected.

Right side condenser door open.

General Safety Instructions:**WARNING**

High voltage and exposed rotating parts are used in the refrigeration unit. Personal injury can result if power is connected.

a. Removal.

- (1) Loosen two set screws (1).
- (2) Carefully pull condenser fan (2) off fan drive shaft (3), being careful not to loose key (4), and remove from condenser shroud (5).

b. Installation.

- (1) Place condenser fan (2) into condenser shroud (5).
- (2) Aline and install condenser fan (2) and key (4) onto fan drive shaft (3).
- (3) Tighten two set screws (1).

4-37. **CONDENSER FAN REPLACEMENT.** - Continued

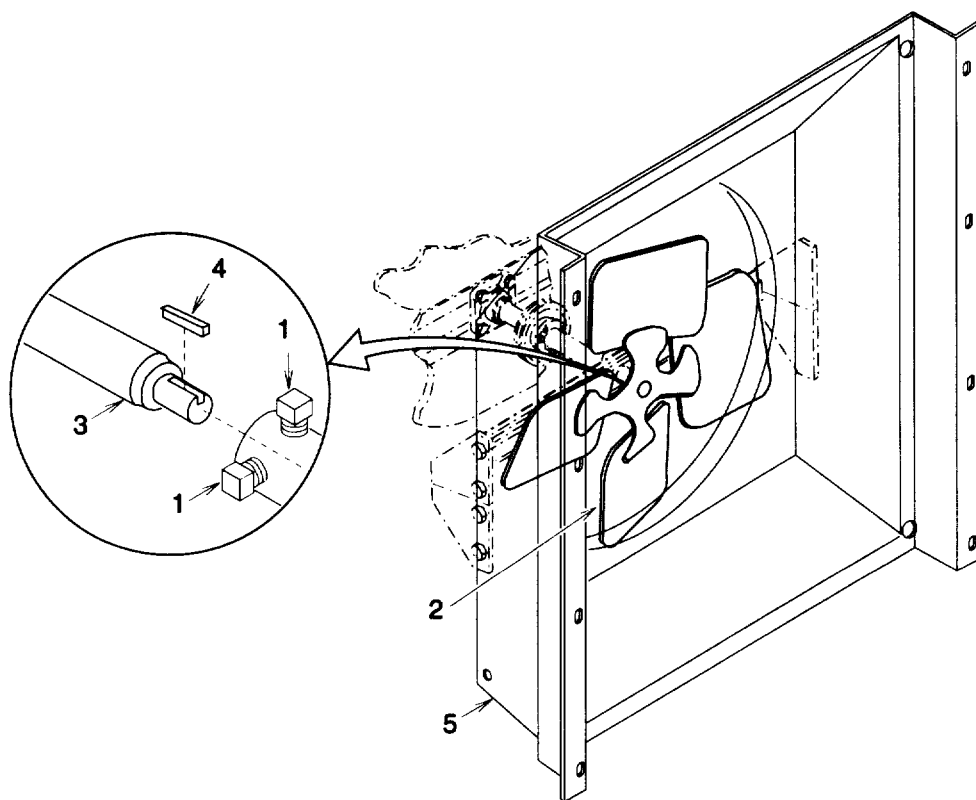


Figure 4-32. Condenser Fan

NOTE

FOLLOW-ON MAINTENANCE:
 Close right side condenser door.
 Connect power and put unit back into service.

4-38. EVAPORATOR FAN REPLACEMENT.

This task covers: a. Removal b. Installation

INITIAL SETUP**Equipment Conditions:**

Refrigeration unit shut down (para 2-7) and power disconnected.

Materials / Parts:

Lock Washers (7)
3, Appendix G

General Safety Instructions:**WARNING**

High voltage and exposed rotating parts are used in the refrigeration unit. Personal injury can result if power is connected

a. Removal.

- (1) Remove seven bolts (1), lock washers (2), flat washers (3), and evaporator air outlet guard (4). Discard lock washers.

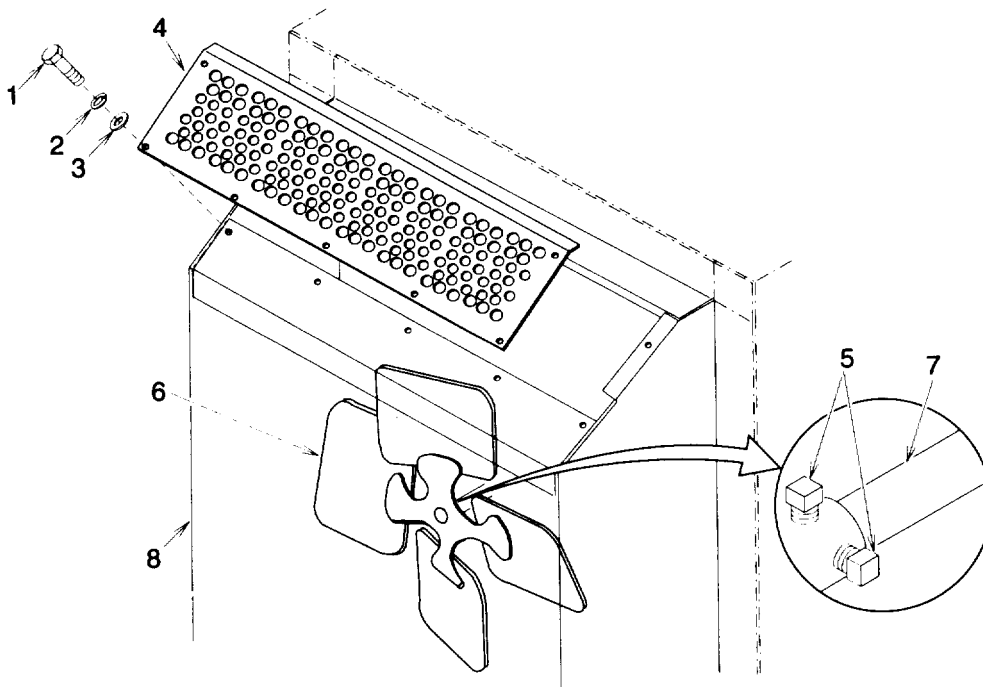


Figure 4-33. Evaporator Fan

- (2) Loosen two set screws (5).
- (3) Carefully pull evaporator fan (6) off fan drive shaft (7) and remove from evaporator housing (8).

4-38. EVAPORATOR FAN REPLACEMENT. - Continued

b. Installation.

- (1) Place evaporator fan (6) into evaporator housing (8) and install onto fan drive shaft (7).
- (2) Tighten two set screws (5) against flat surfaces on fan drive shaft (7).
- (3) Install evaporator air outlet guard (4), seven flat washers (3), new lock washers (2), and bolts (1).

NOTE

**FOLLOW-ON MAINTENANCE:
Connect power and put unit back into service.**

4-39. FLANGE BEARINGS REPLACEMENT.

This task covers: a. Removal b. Installation

INITIAL SETUP

Equipment Conditions:

Refrigeration unit shut down (para 2-7) and power disconnected.

Condenser fan removed (para 4-37).

V belt removed (para 4-36).

Materials/Parts:

Lock Washers (4 Each Bearing)

16, Appendix G

Lock Washers (6)

13, Appendix G

General Safety Instructions:

WARNING

High voltage and exposed rotating parts are used in the refrigeration unit. Personal injury can result if power is connected

a. Removal.

- (1) Remove four bolts (1), lock washers (2), and flat washers (3) from each flange bearings (4) and (5). Discard lock washers.

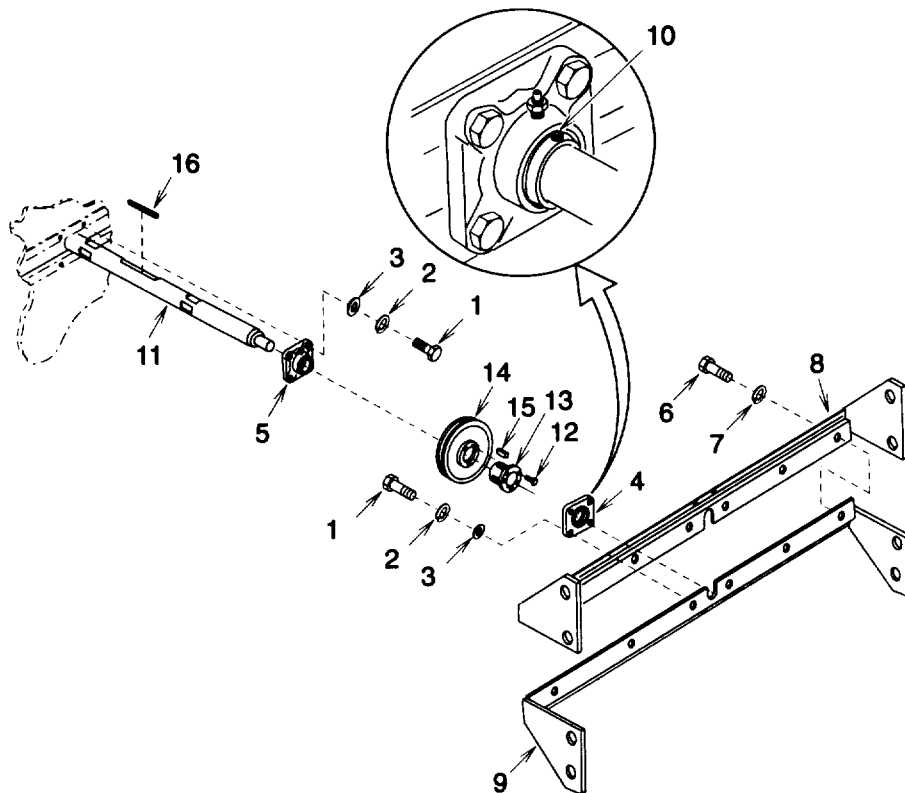


Figure 4-34. Flange Bearings

4-39. FLANGE BEARINGS REPLACEMENT. - Continued

- (2) Remove six bolts (6), lock washers (7), top support (8), and bottom support (9). Discard lock washers.
- (3) Loosen two set screws (10) and remove flange bearing (4) from fan drive shaft (11).
- (4) Remove three bolts (12) and install two bolts back into threaded holes in bushing (13). Tighten bolts evenly to separate bushing from sheave (14). Remove two bolts from bushing.
- (5) Slide bushing (13) and sheave (14) off fan drive shaft (11) being careful not to lose keys (15) and (16). Remove keys.
- (6) Slide flange bearing (5) off fan drive shaft (11).

b. Installation.

- (1) Slide flange bearing (5) onto fan drive shaft (11).
- (2) Install key (16) then slide sheave (14) and bushing (13) onto fan drive shaft (11). Aline bushing over key.
- (3) Install key (15) then aline sheave (14) with key and slide onto bushing (13).
- (4) Install three bolts (12) and tighten evenly to secure sheave (14) to bushing (13).
- (5) Install top support (8) and bottom support (9) around fan drive shaft (11). Secure using six new lock washers (7) and bolts (6).
- (6) Align flange bearings (4) and (5) mounting holes and install four flat washers (3), new lock washers (2), and bolts (1) onto each flange bearing.
- (7) Tighten two set screws (10) against flat surfaces on fan drive shaft (11).

NOTE

**FOLLOW-ON MAINTENANCE:
Install and adjust V belt (para 4-36).
Install condenser fan (para 4-37).
Connect power and put unit back into service.**

4-40. PULLEY REPLACEMENT.

This task covers: a. Removal b. Installation

INITIAL SETUP**Equipment Conditions:**

Refrigeration unit shut down (para 2-7) and power disconnected.
 V belt removed from pulley only (para 4-36).

General Safety Instructions:**WARNING**

High voltage and exposed rotating parts are used in the refrigeration unit. Personal injury can result if power is connected.

-
- a. Removal.** Loosen set screw (1) and remove pulley (2) from AC motor (3) shaft being careful key (4).
- b. Installation.** Install key (4) then align pulley (2) with key and slide to AC motor (3) shaft. Tighten set screw (1).

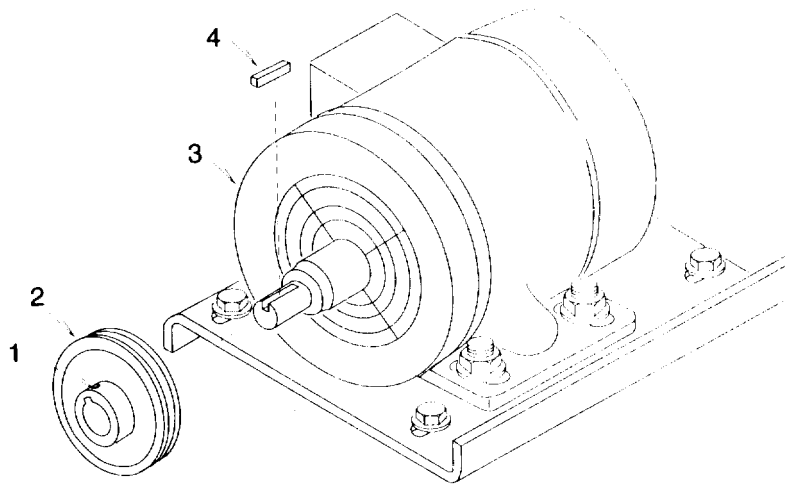


Figure 4-35. Pulley

NOTE

FOLLOW-ON MAINTENANCE:
 Install V belt onto pulley and adjust (para 4-36).
 Connect power and put unit back into service.

4-41. SHEAVE REPLACEMENT.

This task covers: a. Removal b. Installation

INITIAL SETUP**Equipment Conditions:**

Refrigeration unit shut down (para 2-7) and power disconnected.

Condenser fan removed (para 4-37).

V belt removed (para 4-36).

Materials/Parts:

Lock Washers (4)

16, Appendix G

Lock Washers (6)

13, Appendix G

General Safety Instructions:**WARNING**

High voltage and exposed rotating parts are used in the refrigeration unit. Personal injury can result if power is connected.

a. Removal.

- (1) Remove four bolts (1), lock washers (2), and flat washers (3) from flange bearing (4). Discard lock washers.
- (2) Remove six bolts (5), lock washers (6), top support (7), and bottom support (8). Discard lock washers.
- (3) Loosen two set screws (9) and remove flange bearing (4) from fan drive shaft (10).
- (4) Remove three bolts (11) and install two bolts back into threaded holes in bushing (12). Tighten bolts evenly to separate bushing from sheave (13). Remove two bolts from bushing.
- (5) Slide bushing (12) and sheave (13) off fan drive shaft (10) being careful not to lose keys (14) and (15). Remove keys.

b. Installation.

- (1) Install key (15) then slide sheave (13) and bushing (12) onto fan drive shaft (10). Aline bushing over key.
- (2) Install key (14) then aline sheave (13) with key and slide onto bushing (12).
- (3) Install three bolts (11) and tighten evenly to secure sheave (13) to bushing (12).
- (4) Install top support (7) and bottom support (8) around fan drive shaft (10). Secure using six new lock washers (6) and bolts (5).
- (5) Align flange bearing (4) mounting holes and install four flat washers (3), new lock washers (2), and bolts (1) onto flange bearing.
- (6) Tighten two set screws (9) against flat surfaces on fan drive shaft (10).

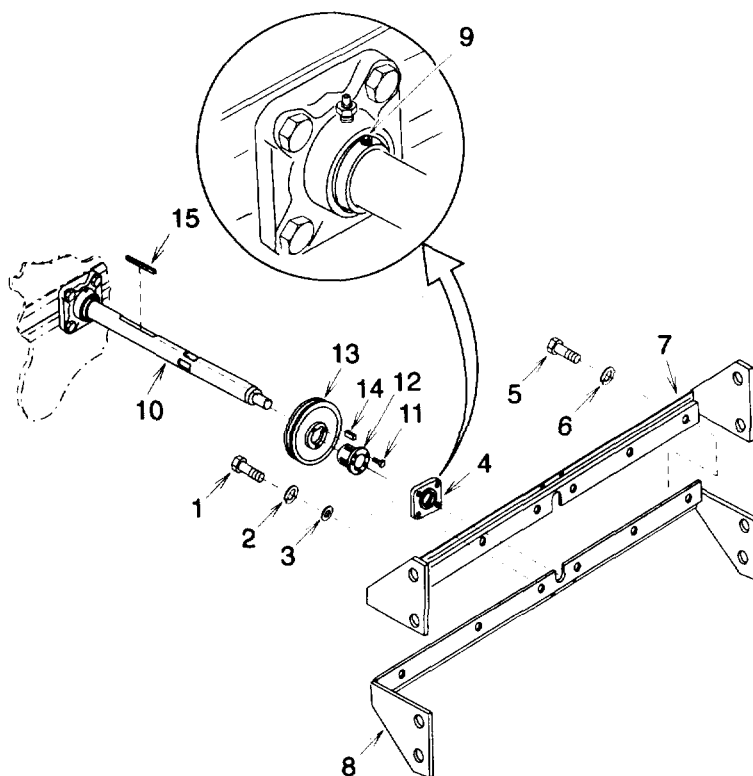


Figure 4-36. Sheave

NOTE

FOLLOW-ON MAINTENANCE:
 Install and adjust V belt (para 4-36).
 Install condenser fan (para 4-37).
 Connect power and put unit back into service.

4-42. SOLENOID VALVE L1 (LIQUID LINE) TESTING AND REPAIR.

This task covers: a. Testing b. Removal c. Installation

INITIAL SETUP**Equipment Conditions:**

Refrigeration unit shut down (para 2-7) and power disconnected.
Left side condenser door open.

Materials/Parts:

Marker tags (2)
7, Appendix E

General Safety Instructions:**WARNING**

High voltage and exposed rotating parts are used in the refrigeration unit. Personal injury can result if power is connected

a. Testing.

- (1) Tag and disconnect tabs (1).
- (2) Using multimeter set to measure continuity, check coil (2) continuity between tabs (1). Continuity should be indicated. If no continuity was indicated, replace coil.
- (3) Using multimeter set to measure continuity, check coil (2) continuity between each tab (1) and coil (2) metal case. No continuity should be indicated. If continuity was indicated, replace coil.
- (4) If no failure was indicated, check tabs (1) and tab housing (3). If damaged, repair or replace per paragraph 4-20.
- (5) Using tags and wiring diagram (fig. 1-4), connect tabs (1). Remove tags.

NOTE

The only authorized repair to the solenoid valve is coil replacement. The coil can be replaced without opening the refrigeration pressure system.

b. Removal.**WARNING**

Do not attempt any disassembly of the solenoid valve other than coil removal with a refrigerant charge in the system. Refrigerant will be sprayed out dangerously if the screws that attach the tube and plunger assembly to the valve body are loosened.

- (1) Tag and disconnect tabs (1).

NOTE

Mounting hardware is not supplied with coil. Screw and lockwasher must be retained for use during installation of coil.

- (2) Remove screw (4), lock washer (5), data plate (6), and coil (2).
- (3) Cut wire leads (7) if necessary and remove grommet (8).

c. Installation.

- (1) Push wire leads (7) through grommet (8) and install grommet into coil (2).
- (2) Install two tab housings (3) and tabs (1) (para 4-20).
- (3) Install coil (2), data plate (6), lock washer (5), and screw (4).
- (4) Using tags and wiring diagram (fig. 1-4), connect tabs (1). Remove tags.

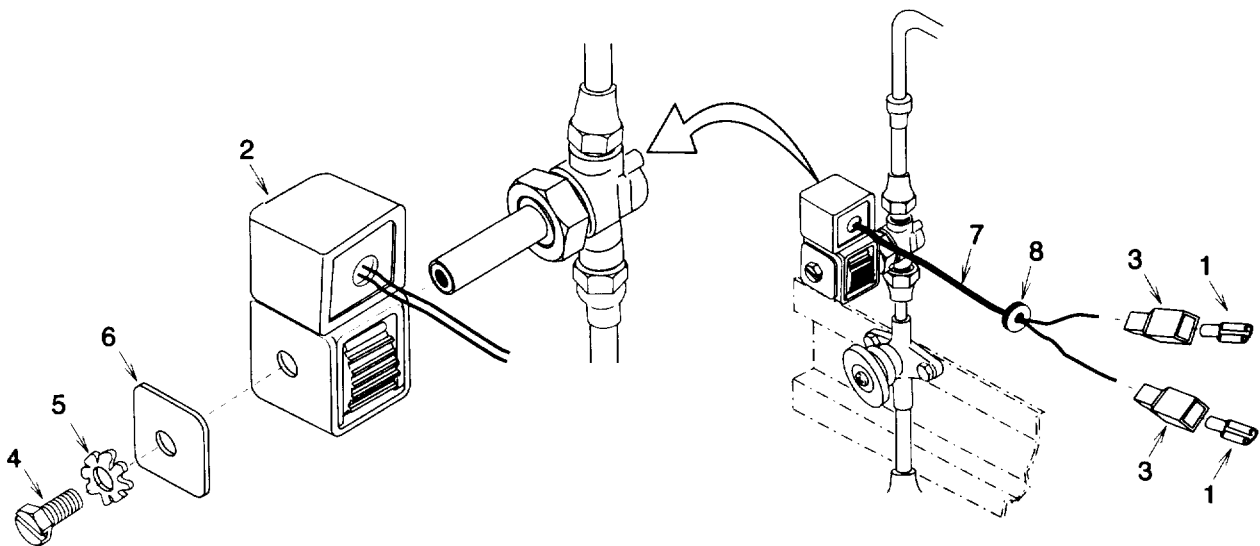


Figure 4-37. Solenoid Valve (Liquid Line)

NOTE

FOLLOW-ON MAINTENANCE:
 Close left side condenser door.
 Connect power and put unit back into service.

4-43. SOLENOID VALVE L2 (DEFROST LINE) TESTING AND REPAIR.

This task covers: a. Testing b. Removal c. Installation

INITIAL SETUP**Equipment Conditions:**

Refrigeration unit shut down (para 2-7) and power disconnected.
Right side condenser door open.

Materials / Parts:

Marker tags (2)
7, Appendix E

General Safety Instructions:**WARNING**

High voltage and exposed rotating parts are used in the refrigeration unit. Personal injury can result if power is connected.

a. Testing.

- (1) Tag and disconnect tabs (1).
- (2) Using multimeter set to measure continuity, check coil (2) continuity between tabs (1). Continuity should be indicated. If no continuity was indicated, replace coil.
- (3) Using multimeter set to measure continuity, check coil (2) continuity between each tab (1) and coil (2) metal case. No continuity should be indicated. If continuity was indicated, replace coil.
- (4) If no failure was indicated, check tabs (1) and tab housing (3). If damaged, repair or replace per paragraph 4-20.
- (5) Using tags and wiring diagram (fig. 14), connect tabs (1). Remove tags.

NOTE

The only authorized repair to the solenoid valve is coil replacement. The coil can be replaced without opening the refrigeration pressure system.

b. Removal.**WARNING**

Do not attempt any disassembly of the solenoid valve other than coil removal with a refrigerant charge in the system. Refrigerant will be sprayed out dangerously if the screws that attach the tube and plunger assembly to the valve body are loosened.

- (1) Tag and disconnect tabs (1).

NOTE

Mounting hardware is not supplied with coil. Screw and lockwasher must be retained for use during installation of coil.

- (2) Remove screw (4), lock washer (5), data plate (6), and coil (2).
- (3) Cut wire leads (7) if necessary and remove grommet (8).

c. Installation.

- (1) Push wire leads (7) through grommet (8) and install grommet into coil (2).
- (2) Install two tab housings (3) and tabs (1) (para 4-20).
- (3) Install coil (2), data plate (6), lock washer (5), and screw (4).
- (4) Using tags and wiring diagram (fig. 14), connect tabs (1). Remove tags.

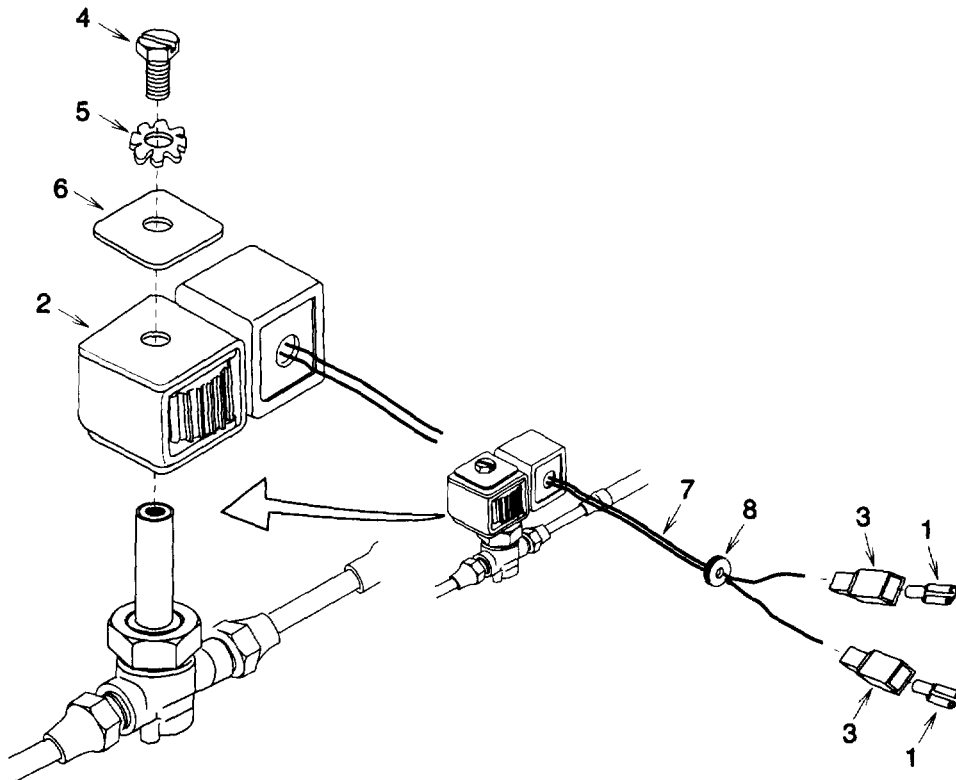


Figure 4-38. Solenoid Valve (Defrost Line)

NOTE

FOLLOW-ON MAINTENANCE:
Close right side condenser door.
Connect power and put unit back into service.

4-44. GASKET (HEAT SHIELD) REPLACEMENT.

This task covers: a. Removal b. Installation

INITIAL SETUP

Equipment Conditions:

Refrigeration unit shut down (para 2-7) and power disconnected.

Refrigeration unit removed from refrigerator enclosure (para 4-6).

Materials/Parts:

Silicone RTV

20, Appendix E

Gasket

F-9, Appendix F

Gasket

F-10, Appendix F

Gasket

F-11, Appendix F

Gasket

F-12, Appendix F

General Safety Instructions:

WARNING

High voltage and exposed rotating parts are used in the refrigeration unit. Personal injury can result if power is connected.

a. Removal.

NOTE

Remove only the individual gasket pieces that need to be replaced.

- (1) Remove nine screws (1), one each gasket retainer strips (2) and (3), and top outside gasket (4). Repeat for bottom outside gasket.
- (2) Remove eight screws (1), two gasket retainer strips (2), and top inside gasket (5). Repeat for bottom inside gasket.
- (3) Remove 12 screws (1), three gasket retainer strips (2), and right inside gasket (6). Repeat for left inside gasket.
- (4) Remove 13 screws (1), two gasket retainer strips (2), one gasket retainer strip (3), and right outside gasket (7). Repeat for left outside gasket.

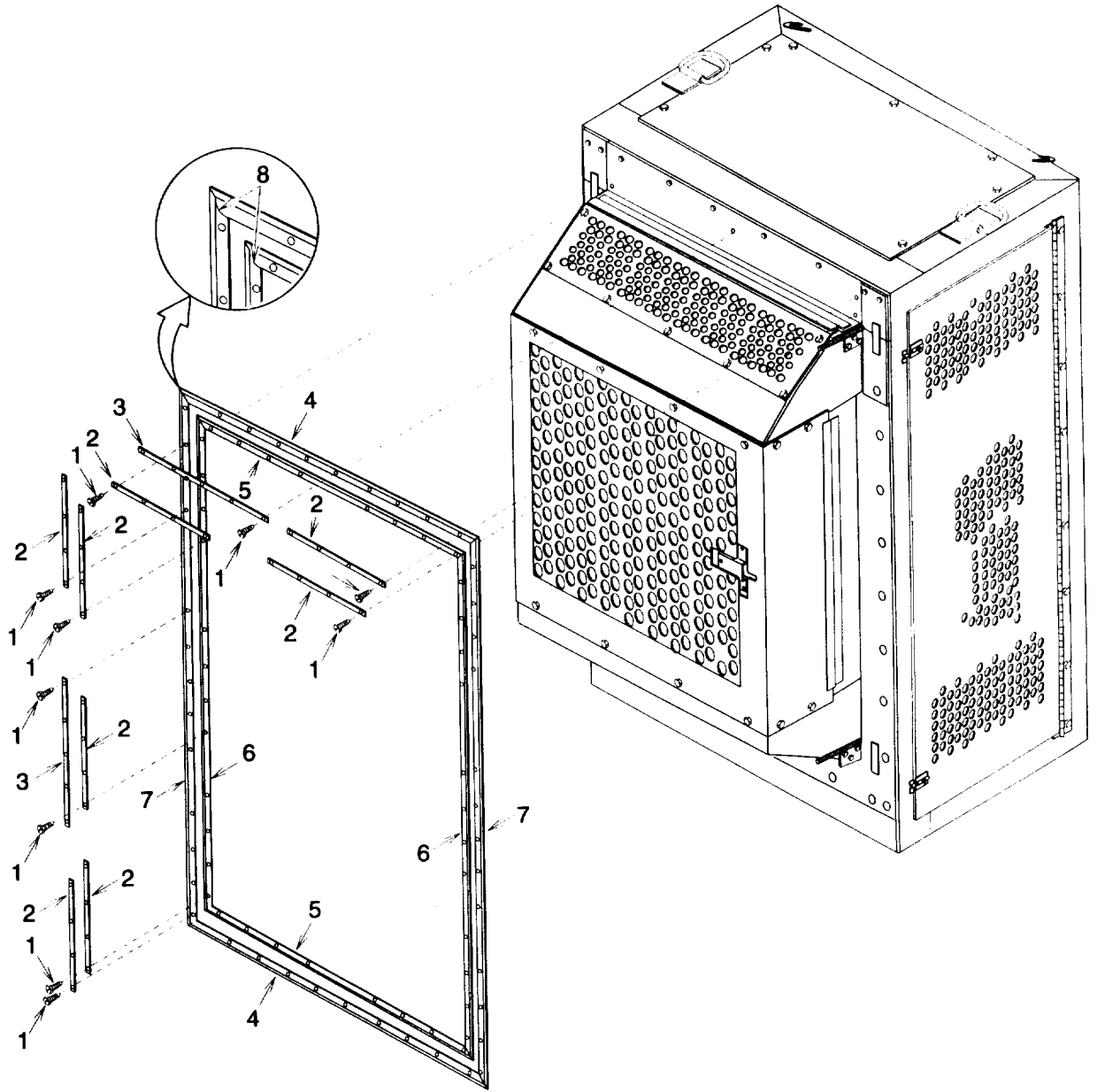


Figure 4-39. Gasket (Heat Shield)

4-44. GASKET (HEAT SHIELD) REPLACEMENT. - Continued**b. Installation.**

- (1) Fabricate the required gasket(s) (appendix F).
- (2) Install right outside gasket (7), one gasket retainer strip (3), two gasket retainer strips (2), and 13 screws (1). Repeat for left outside gasket.
- (3) Install right inside gasket (6), three gasket retainer strips (2), and 12 screws (1). Repeat for left inside gasket.
- (4) Install top inside gasket (5), two gasket retainer strips (2), and eight screws (1). Repeat for bottom inside gasket.
- (5) Install top outside gasket (4), one each gasket retainer strips (2) and (3), and nine screws (1). Repeat for bottom outside gasket.
- (6) Coat the cut surfaces of gasket (4), (5), (6), and (7) with silicone RTV to seal foam.
- (7) Seal four seams (8) with silicone RTV.

NOTE

FOLLOW-ON MAINTENANCE:
Install refrigeration unit onto refrigerator enclosure (para 4-6).
Connect power and put unit back into service.

SECTION VI PREPARATION FOR STORAGE OR SHIPMENT**4-45. ADMINISTRATIVE STORAGE.**

Placement of equipment in administrative storage should be for short periods of time (1 to 45 days) when a shortage of maintenance effort exists. Items should be in mission readiness within 24 hours or within the time factors as determined by the directing authority. During the storage period, appropriate maintenance records will be kept.

- a. Before placing the equipment in administrative storage, current preventive maintenance checks and services should be completed, shortcomings and deficiencies should be corrected, and all Modification Work Orders (MWO) should be applied.
- b. Storage site selection. Inside storage is preferred for items selected for administrative storage. If inside storage is not available, trucks, vans, conex containers, and other containers may be used.
- c. Pump down refrigeration unit.

WARNING

High voltage and exposed rotating parts are contained in the refrigeration unit. Personal injury can result if power is connected.

- (1) Be sure refrigeration unit is shut down and power is disconnected then remove two isolation valve caps (1) and shut off valve caps (2).
- (2) Close hot gas stop valve (3).
- (3) Close receiver outlet valve (4).
- (4) Be sure the condenser side doors are closed and operate the refrigeration unit (para 2-5) until it shuts down automatically.
- (5) Shut down the refrigeration unit (para 2-7) and disconnect power.
- (6) Close receiver inlet valve (5), compressor shut off valves (6), and liquid stop valve (7).
- (7) Install two shut off valve caps (2) and isolation valve caps (1).
- (8) Place a marker tag (7, appendix E) on or near the control panel cover stating "THE REFRIGERATION UNIT HAS BEEN PUMPED DOWN, DO NOT OPERATE UNTIL ALL VALVES HAVE BEEN PROPERLY SET, EQUIPMENT DAMAGE WILL OCCUR."

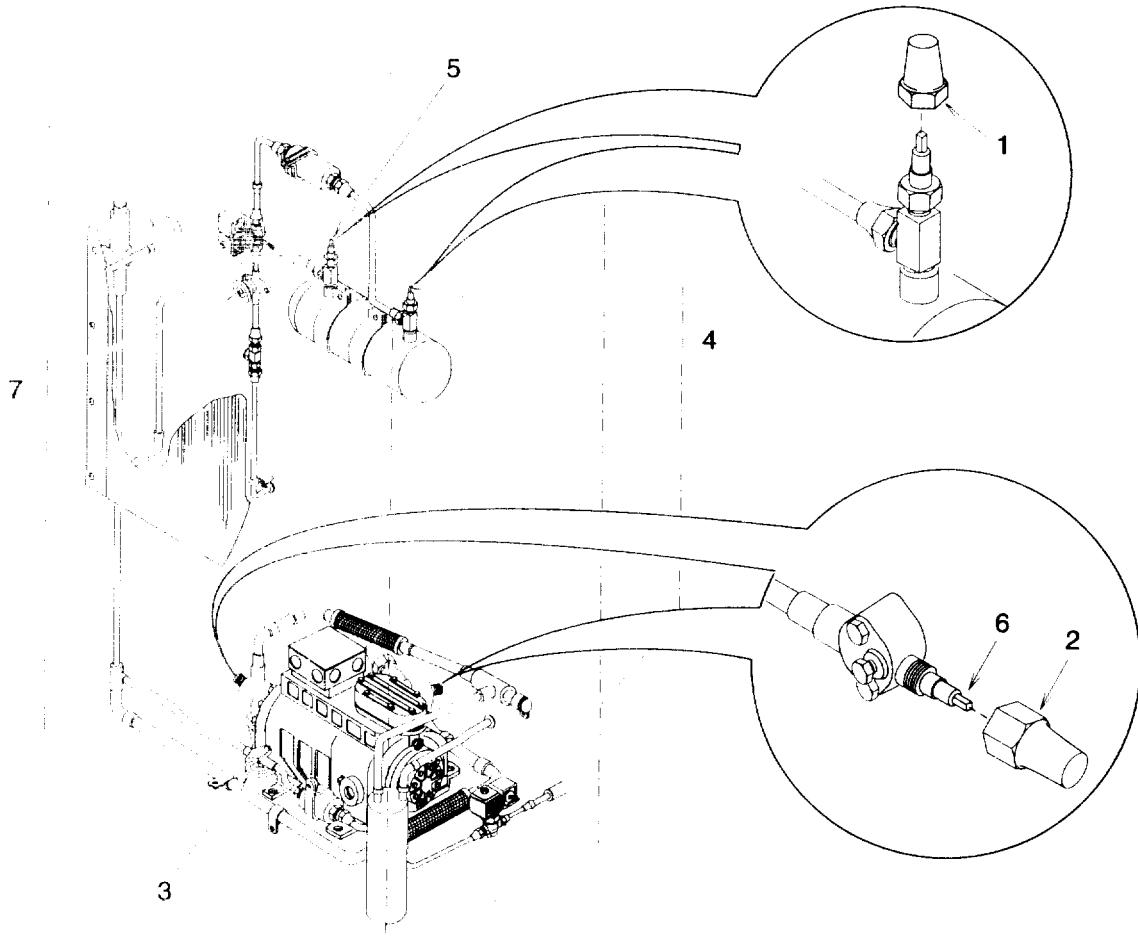


Figure 4-40. Refrigeration System Pump Down

4-46. LONG TERM STORAGE OR SHIPMENT.

Placement of equipment in long term storage should be for extended periods of time (45 days or more).

- a. Before placing the equipment in long term storage, current preventive maintenance checks and services should be completed, shortcomings and deficiencies should be corrected, and all Modification Work Orders (MWO) should be applied.
- b. Open both side condenser doors and both front bottom doors.
- c. Loosen four compressor mount locknuts (1, fig. 4-41). Tighten four screws (2) just to the point where shipping bracket (3) cannot be removed from spring (4). Tighten four locknuts.

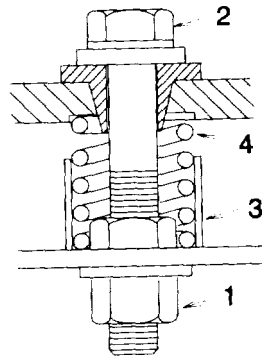


Figure 4-41. Compressor Mount

- d. Close both side condenser doors and both front bottom doors.

NOTE

Refrigerant and oil will not be removed from the system.

- e. Preserve the refrigeration unit in accordance with MIL-P-116, method I.
- f. Cover all openings into the electric motor, evaporator panel, glass gages, name plates and instruction panels, switches, control boxes, etc., with waterproof paper and seal with tape conforming to PPP-T-60, or with a barrier material conforming to grade A of MIL-B-121 and secured in place.
- g. Package the refrigeration unit in accordance with ASTM D 3951, level A or Commercial.
- h. Refrigeration unit shall be packed upright in an open crate or cleated plywood box conforming to type V, style A of MIL-C-52950 or style B for overseas. Each unit shall be secured and the container closed and strapped with 3/4 inch by 0.023 inch steel. The strapping shall be applied over the horizontal top, bottom, and intermediate cleats of the side and ends.
- i. Shipping containers shall be marked with the words "UP" and "THIS SIDE DOWN" shall appear on each shipping container.

CHAPTER 5

DIRECT SUPPORT MAINTENANCE INSTRUCTIONS

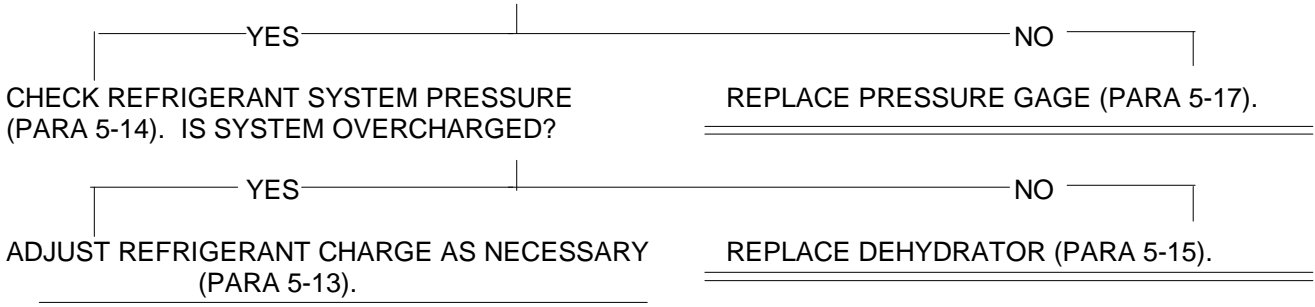
SECTION I DIRECT SUPPORT TROUBLESHOOTING INSTRUCTIONS

5-1. TROUBLESHOOTING.

The following procedures are listed in order of the most probable malfunctions. Each malfunction is followed by test or inspection procedures in logical order to isolate and identify the fault and actions required to correct it. This section cannot list all the possible malfunctions that may occur with the equipment. If a malfunction occurs that is not listed or actions listed do not correct a malfunction, notify your supervisor.

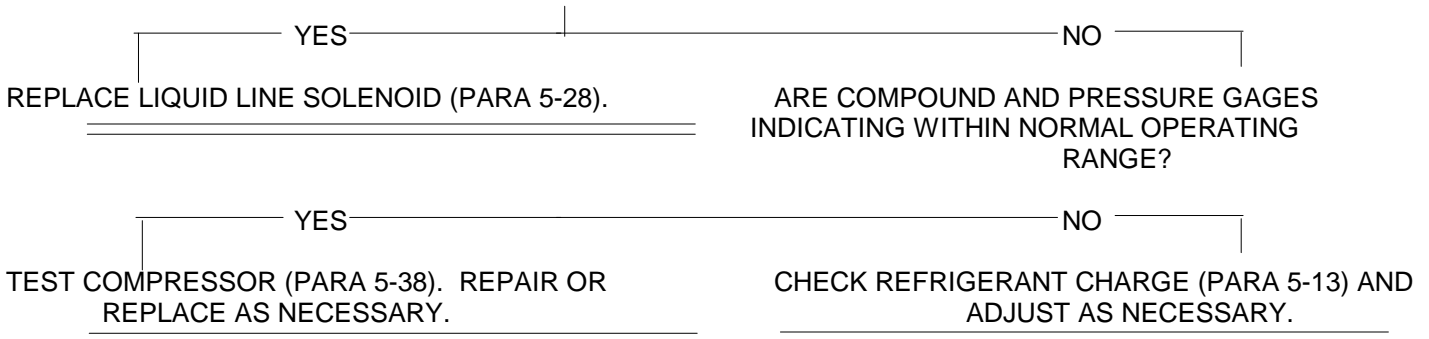
a. Pressure Gage Indicates Above Operating Range.

INSTALL SERVICE MANIFOLD (PARA 5-7) AND OPERATE REFRIGERATION UNIT (PARA 2-5). DOES SERVICE MANIFOLD GAGE READING MATCH PRESSURE GAGE READING?



b. Compressor Operates For Short Period Then Stops.

OPERATE REFRIGERATION UNIT (PARA 2-5) AND OBSERVE COMPOUND GAGE. DOES PRESSURE DROP RAPIDLY?



c. Pressure and Compound Gages Indicate Similar Reading.

INSTALL SERVICE MANIFOLD (PARA 5-7) AND OPERATE REFRIGERATION UNIT (PARA 2-5). DOES SERVICE MANIFOLD GAGE READINGS MATCH PRESSURE AND COMPOUND GAGE READINGS?

YES

REPLACE EXPANSION VALVE (PARA 5-34).

NO

REPLACE PRESSURE (PARA 5-17) OR COMPOUND (PARA 5-16) GAGE(S) AS NECESSARY.

SECTION II DIRECT SUPPORT MAINTENANCE PROCEDURES

5-2. CONTROL PANEL COVER REPAIR.

This task covers: a. Removal b. Installation

INITIAL SETUP

Tools:

Brush
1, Section III, Appendix B

Materials/Parts:

General Purpose Adhesive
14, Appendix E
Wiping Rag
3, Appendix E
Acetone
18, Appendix E
Methyl-Ethyl Ketone
19, Appendix E
Gaskets (2)
2, Figure F-3, Appendix F
Gasket
3, Figure F-3, Appendix F
Gasket
4, Figure F-3, Appendix F

Equipment Conditions:

Control panel cover removed (para 4-16).

General Safety Instructions:

WARNING

Acetone and methyl-ethyl ketone (MEK) are flammable and their vapors can be explosive. Repeated or prolonged skin contact or inhalation of vapors can be toxic. Use in a well ventilated area, wear gloves, and keep away from sparks or flame.

Repair.

NOTE

Repair is limited to replacement of gasket material.

(1) Remove as much old gasket material (1), (2), or (3) as possible by pulling or scraping it away from the control panel cover (4).

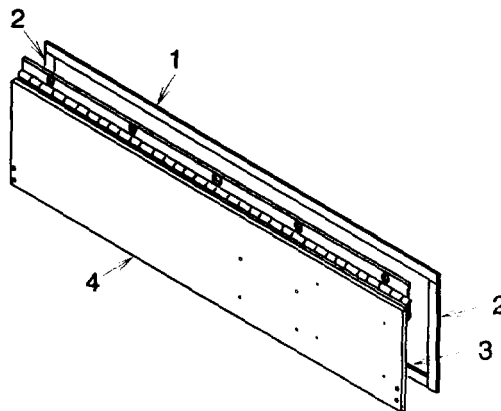


Figure 5-1. Control panel Cover.

5-2. CONTROL PANEL COVER REPAIR. - Continued

- (2) Soften and remove old adhesive and gasket (1), (2), or (3) residue, using acetone or methyl-ethyl ketone (MEK) and a stiff brush.
- (3) Fabricate new gasket (1), (2), or (3) per appendix F.
- (4) Be sure that the attaching surface of the control panel cover (4) is clean and free of paint and old adhesive material.
- (5) Coat the mating surfaces of the control panel cover (4) and gasket (1), (2), or (3) with adhesive. Let both surfaces air dry until adhesive is tacky, but will not stick to fingers.
- (6) Starting with an end, carefully press gasket (1), (2), or (3) onto the control panel cover (4). Press firmly overall to ensure complete contact.

NOTE

**FOLLOW-ON MAINTENANCE:
Install control panel cover (para 4-16).**

5-3. CIRCUIT BREAKER COVER REPAIR.

This task covers: Repair

INITIAL SETUP

Tools:

Brush
1, Section 111, Appendix B

Materials/Parts:

General Purpose Adhesive
14, Appendix E
Wiping Rag
3, Appendix E
Acetone
18, Appendix E
Methyl-Ethyl Ketone
19, Appendix E
Gaskets (2)
5, Figure F-3, Appendix F
Gaskets (2)
Figure F-25, Appendix F

Equipment Conditions:

Circuit breaker cover removed (para 4-21).

General Safety Instructions:

WARNING

Acetone and methyl-ethyl ketone (MEK) are flammable and their vapors can be explosive. Repeated or prolonged skin contact or inhalation of vapors can be toxic. Use in a well ventilated area, wear gloves, and keep away from sparks or flame.

Repair.

NOTE

Repair is limited to replacement of gasket material.

- (1) Remove as much old gasket material (1) or (2) as possible by pulling or scraping it away from the circuit breaker cover (3).

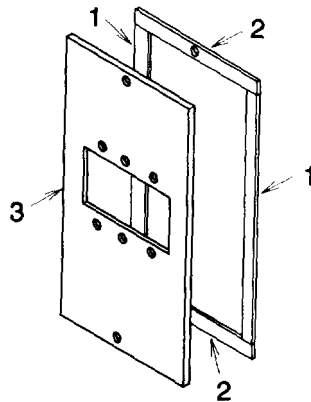


Figure 5-2.. Circuit Breaker Cover.

5-3. CIRCUIT BREAKER COVER REPAIR.- Continued

- (2) Soften and remove old adhesive and gasket (1) or (2) residue, using acetone or methyl-ethyl ketone (MEK) and a stiff brush.
- (3) Fabricate new gasket (1) or (2) per appendix F.
- (4) Be sure that the attaching surface of the circuit breaker cover (3) is clean and free of paint and old adhesive material.
- (5) Coat the mating surfaces of the circuit breaker cover (3) and gasket (1) or (2) with adhesive. Let both surfaces air dry until adhesive is tacky, but will not stick to fingers.
- (6) Starting with an end, carefully press gasket (1) or (2) onto the circuit breaker cover (3). Press firmly overall to ensure complete contact.

NOTE

**FOLLOW-ON MAINTENANCE:
Install circuit breaker cover (para 4-21).**

5-4. CONTROL BOX COVER REPAIR.

This task cover: Repair

INITIAL SETUP

Tools:

Brush

1, Section 1111, Appendix B

Materials/Parts:

Lock Washers (2)

1, Appendix G

General Purpose Adhesive

14, Appendix E

Wiping Rag

3, Appendix E

Acetone

18, Appendix E

Methyl-Ethyl Ketone

19, Appendix E

Gaskets (2)

1, Figure F-3, Appendix F

Gasket

Figure F-24, Appendix F

Equipment Conditions:

Refrigeration unit shut down (para 2-7) and power disconnected.

Control panel cover open.

General Safety Instructions:**WARNING**

- **High voltage is used in the refrigeration unit. Personal injury can result if power is connected.**
- **Acetone and methyl-ethyl ketone (MEK) are flammable and their vapors can be explosive. Repeated or prolonged skin contact or inhalation of vapors can be toxic. Use in a well ventilated area, wear gloves, and keep away from sparks or flame.**

Repair.**NOTE****Repair is limited to replacement of gasket material.**

- (1) Remove two bolts (1) and lock washers (2). Open control box cover (3). Discard lock washers.
- (2) Remove as much old gasket material (4) or (5) as possible by pulling or scraping it away from the control box cover (3).
- (3) Soften and remove old adhesive and gasket (4) or (5) residue, using acetone or methyl-ethyl ketone (MEK) and a stiff brush.
- (4) Fabricate new gasket (4) or (5) per appendix F.
- (5) Be sure that the attaching surface of the control box cover (3) is clean and free of paint and old adhesive material.
- (6) Coat the mating surfaces of the control box cover (3) and gasket (4) or (5) with adhesive. Let both surfaces air dry until adhesive is tacky, but will not stick to fingers.

5-4. **CONTROL BOX COVER REPAIR.** - Continued

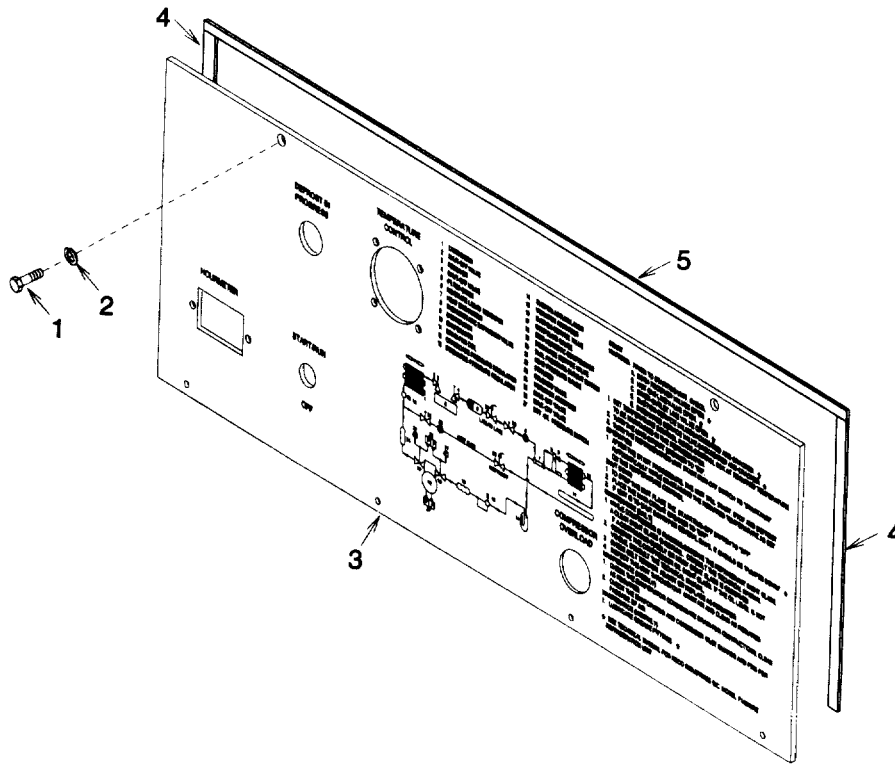


Figure 5-3. Control Box Cover.

- (7) Starting with an end, carefully press gasket (4) or (5) onto the control box cover (3). Press firmly overall to ensure complete contact.
- (8) Install two new lock washers (2) and bolts (1).

NOTE
FOLLOW-ON MAINTENANCE:
Close control panel.

5-5. FAN DRIVE SHAFT REPLACEMENT.

This task covers: a. Removal b. Installation

INITIAL SETUP

Equipment Conditions:

Refrigeration unit shut down (para 2-7) and power disconnected.
 Evaporator fan removed (para 4-38).
 Condenser fan removed (para 4-37).
 Sheave removed (para 4-41).
 Condenser coil removed (para 5-20).

General Safety Instructions:

WARNING

High voltage and exposed rotating parts are used in the refrigeration unit. Personal injury can result if power is connected.

- a. **Removal.** Remove fan drive shaft (1).
- b. **Installation.** Install fan drive shaft (1).

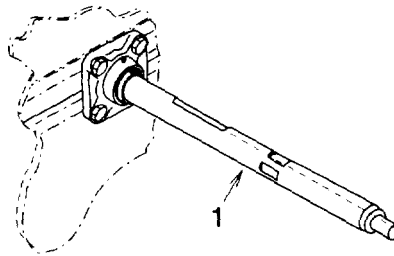


Figure 5-4. Fan Drive Shaft

NOTE

FOLLOW-ON MAINTENANCE:
 Install sheave (para 4-41).
 Install condenser fan (para 4-37).
 Install evaporator fan (para 4-38).
 Install condenser coil (para 5-20).
Connect power and put unit back into service.

5-6. REFRIGERATION SYSTEM REPAIRS.

The refrigeration system must be totally discharged (para 5-8) before any maintenance is performed on system components. Leak testing (para 5-11) and dehydrator replacement (para 5-15) are required after any system component has been removed and replaced. The system must be properly evacuated (para 5-12) and charged (para 5-13) to function correctly.

5-7. SERVICE MANIFOLD INSTALLATION.

This task covers: a. Installation b. Removal

INITIAL SETUP

Tools:

- Gloves
- 1, Section III, Appendix B
- Goggles
- 1, Section III, Appendix B
- Refrigerant Recovery and Recycle Unit
- 6, Section III, Appendix B

Equipment Conditions:

- Refrigeration unit shut down (para 2-7) and power disconnected.
- Front bottom doors open.
- Right side condenser door open.

General Safety Instructions:

WARNING

- High voltage and rotating parts are used in the refrigeration unit. Personal injury can result if power is connected.
- Dangerous chemical refrigerant under pressure is used in the operation of this equipment. Use great care to avoid contact with liquid refrigerant. Work in a well ventilated area.

General Safety Instructions:

WARNING

- Sudden and irreversible tissue damage can result from freezing. Wear gloves and face protector or safety glasses in any situation where skin or eye contact with refrigerant is possible.
- Heat may cause the refrigerant to decompose and release irritating, toxic, and corrosive gases. Prevent contact of refrigerant with flame or hot surfaces.
- Compressor lubricating oil used in this refrigeration system is caustic. Wear gloves and a face protector or safety glasses in any situation where skin or eye contact is possible. If oil does contact skin, wash with soap and water.

a. Installation.

CAUTION

Using excessive force when opening or closing valves can cause damage to the valve seats.

NOTE

The compressor shut off valves can be adjusted to three positions, fully closed to block the refrigerant tubes and isolate the compressor and service port, fully open to allow flow from piping to compressor but not the service port, and cracked (one turn closed from fully open) to allow flow from piping to compressor and service port on valve.

- (1) Remove two shut off valve caps and turn the shut off valves fully counterclockwise to backseat them.

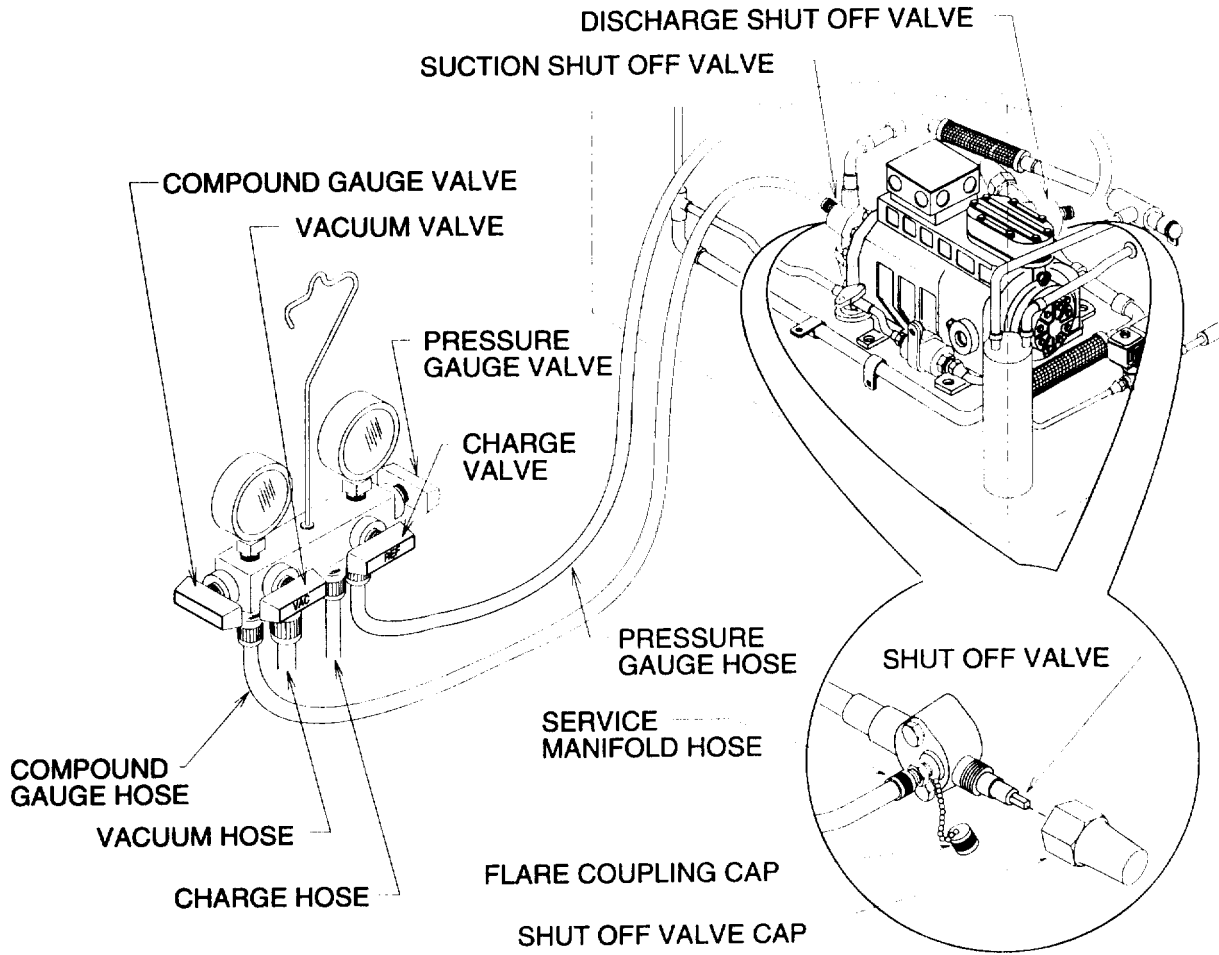


Figure 5-5. Service Manifold Installation

5-7. SERVICE MANIFOLD INSTALLATION. - Continued

- (2) Remove two flare coupling caps.
- (3) Check that all four service manifold valves are closed.

NOTE

Push switch in condenser side door will prevent refrigeration unit from operating if door is open. Do not pass the service manifold hoses through the condenser side door if the refrigeration unit will need to be operated.

- (4) Pass service manifold hoses through front bottom doors and connect service manifold pressure gauge hose to discharge flare coupling and compound gauge hose to suction flare coupling.
- (5) Connect service manifold charge hose to recovery unit.
- (6) Turn discharge and suction shut off valves one turn clockwise to crack open valves.
- (7) Open service manifold pressure gauge valve and charge valve. Operate recovery unit and allow refrigerant to purge for 3-5 seconds. Close pressure gauge and charge valves then shut down recovery unit.
- (8) Open service manifold compound gauge valve and charge valve. Operate recovery unit and allow refrigerant to purge for 3-5 seconds. Close compound gauge and charge valves then shut down recovery unit.

b. Removal.

- (1) Turn shut off valves fully counterclockwise to backseat them.
- (2) Open service manifold pressure and compound gauge valves.
- (3) Open service manifold charge valve. Operate recovery unit and allow refrigerant to purge from hoses.
- (4) Close service manifold valves.
- (5) Shut down recovery unit.
- (6) Disconnect service manifold pressure gauge hose from discharge flare coupling and compound gauge hose from suction flare coupling.
- (7) Install two shut off valve and flare coupling caps.

NOTE**FOLLOW-ON MAINTENANCE:**

Close front bottom doors.
Close right side condenser door.

5-8. DISCHARGING THE REFRIGERANT SYSTEM.

This task covers: Discharge

INITIAL SETUPEquipment Conditions:

Service manifold installed (para 5-7).

Discharge.

- (1) Check that the refrigerant system has not been pumped down (para 4-45). If it has, open necessary valves (para 4-8) to allow discharge of all refrigerant.

CAUTION

Follow instructions for specific refrigerant recovery unit being used to avoid compressor oil loss. Loss of oil could result in compressor damage.

NOTE

Venting tetrafluoroethane refrigerant into the atmosphere rather than recovering it is subject to pending EPA restrictions. Venting the refrigerant may be a violation of public law and subject to severe penalties.

- (2) Open service manifold pressure and compound gauge valves.
- (3) Open service manifold charge valve. Operate recovery unit until all refrigerant has been removed from system.
- (4) Close service manifold valves.
- (5) Shut-down refrigerant recovery unit.

5-8. DISCHARGING THE REFRIGERANT SYSTEM. - Continued

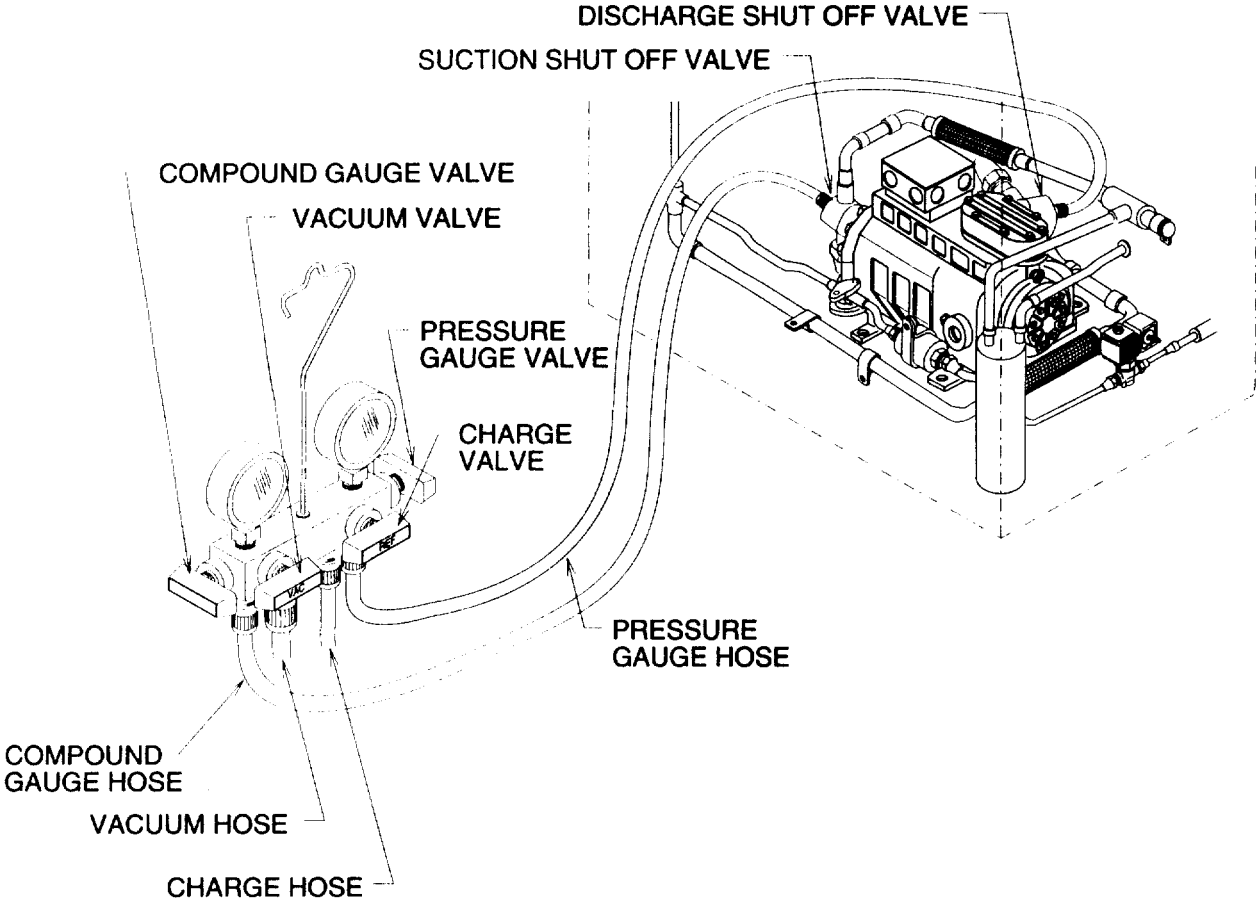


Figure 5-6. Discharging Refrigerant

5-9. PURGING THE REFRIGERANT SYSTEM.

This task covers: Purge

INITIAL SETUPTools:

Nitrogen Regulator
5, Section III, Appendix B

Materials/Parts:

Nitrogen
11, Appendix E

Equipment Conditions:

Refrigerant system discharged (para 5-8).

General Safety Instructions:

WARNING

- **Never pressurize refrigerant lines with oxygen, mixture with oil could cause an explosion.**
- **The pressure in a nitrogen cylinder can exceed 2000 psi. A nitrogen pressure regulator should be used at all times to avoid personal injury.**
- **Nitrogen is an inert gas that can cause suffocation and must be discharged in a well ventilated area.**

Purge. The refrigeration system must be purged with dry nitrogen before brazing is performed on any component. A flow of dry nitrogen should be continued during all brazing operations to minimize internal oxidation and scaling.

- (1) Disconnect charge hose from recovery unit and connect to nitrogen regulator and nitrogen tank.
- (2) Disconnect the compound gage hose from the service manifold and place end in a suitable container to catch any oil that may come out.
- (3) Be sure the service manifold compound gage and vacuum valves are closed.
- (4) Open the service manifold pressure gage and charge valves.
- (5) Open the nitrogen tank valve and adjust the regulator so that approximately 1-2 cfm (0.028-0.057 m³/minute) of nitrogen flows through the system.
- (6) Check discharge from the hose attached to the suction service valve to be sure that no oil is being forced out of the system.
- (7) Perform any brazing/debrazing operations necessary (para 5-10).
- (8) When purging is completed, close nitrogen tank valve.
- (9) Disconnect the charge hose from nitrogen regulator.
- (10) Connect the compound gage hose to service manifold.

5-9. PURGING THE REFRIGERANT SYSTEM. - Continued

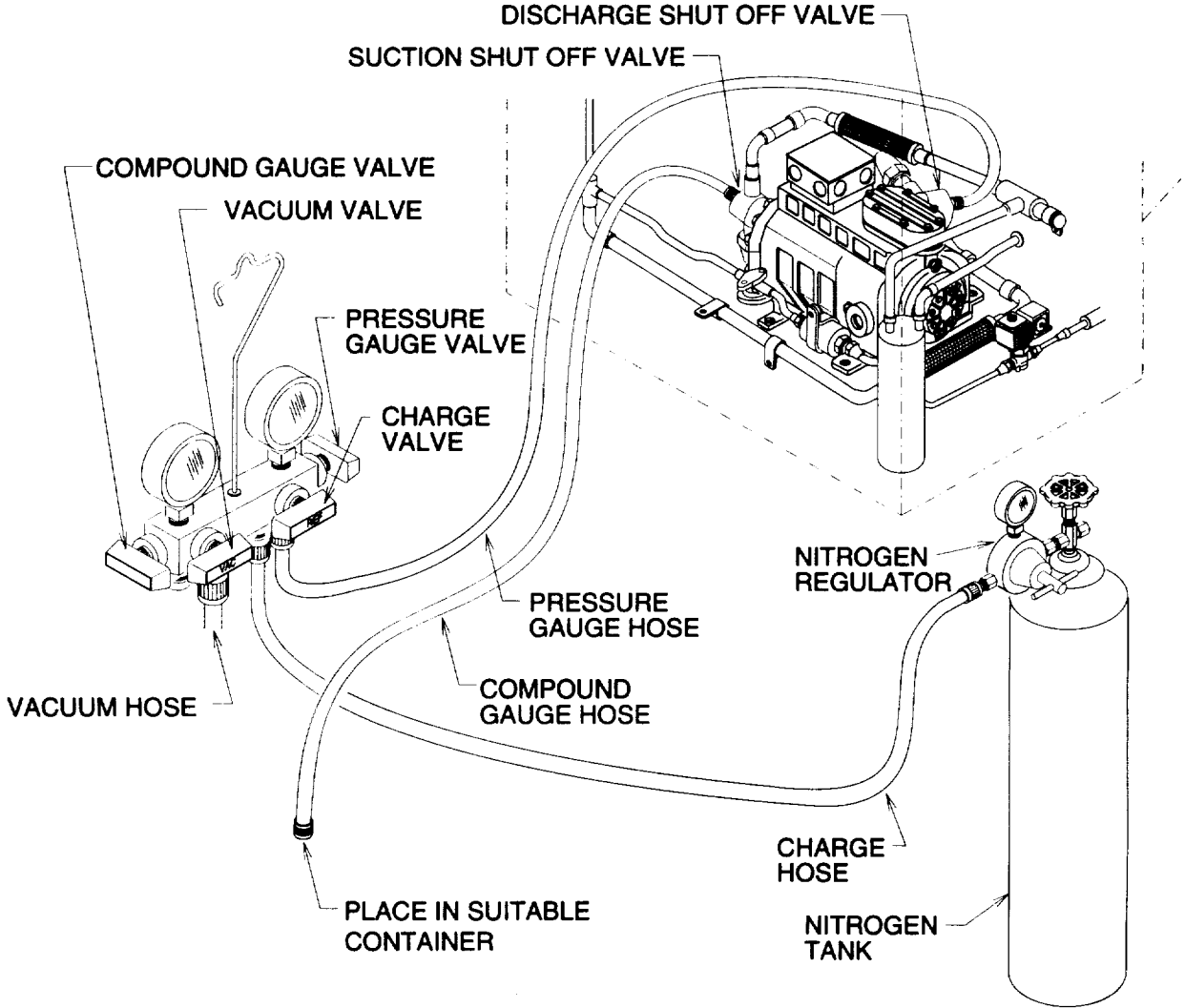


Figure 5-7. Nitrogen Tank Connection

5-10. BRAZING/DEBRAZE PROCEDURE.

This task covers: a. Debraze b. Clean c. Braze

INITIAL SETUP

Tools:

Wire Brush
1, Section III, Appendix B

Materials/Parts:

Brazing Alloy
15 or 16, Appendix E
Brazing Flux
9, Appendix E
Rags
3, Appendix E
Abrasive Cloth
13, Appendix E

Equipment Conditions:

Refrigerant system discharged (para 5-8) and purged (para 5-9).

General Safety Instructions:



Brazing alloys and flux contain materials which are hazardous to health. Avoid breathing vapors or fumes from brazing operations. Perform operations only in well ventilated areas. Wash hands with soap and water after handling brazing alloys and flux. Wear gloves and protective goggles or face shield to protect against burns.

a. Debraze.

- (1) Protect wiring harnesses and other components with appropriate heat shields.

NOTE

It may be easier to access a component by cutting or debrazing the copper lines in accessible areas and removing part of the interconnecting tubing with the component.

- (2) If debrazing a joint on a valve, disassemble the valve to the extent possible and wrap all but the joint with wet rag to act as a heat sink.

5-10. BRAZING/DEBRAZE PROCEDURE. - Continued**WARNING**

Never use a heating torch on any part that contains refrigerant. Heat may cause the refrigerant to decompose and release irritating, toxic, and corrosive gases. All refrigerant must be discharged from the system and the entire system must be purged with dry nitrogen before beginning any brazing operation.

CAUTION

If heat is applied slowly, or only on one side, the entire component or length of tubing will be heated and filler alloy in adjacent joints may also be melted.

- (3) Check that the system is being purged (para 5-9) and apply sufficient heat uniformly around the joint to quickly melt the filler alloy. Remove heat as soon as the joint is separated.
- b. Clean. All filler alloy must be cleaned from debrazed joints before reassembly. Heat each piece of the joint until the filler is melted and then wipe it away with a wire brush. Be sure no filler alloy or other debris is left inside any tubing, fitting, or component. Use abrasive cloth as necessary to clean joints.
- c. Braze.
- (1) Protect wiring harnesses and other components with appropriate heat shields.

NOTE

- All joints, except those provided with flare fittings, are made by brazing in accordance with MIL-B-7883, except that radiographic examination is not required.
 - Grade IV or VI brazing alloy and Type-B flux, as specified in MIL-B-7883, must be used for all copper to brass joints. Grade III brazing alloy may be substituted for Grade IV or VI for copper to copper joints, flux is not required for copper to copper joints.
- (2) If brazing a joint on a valve, disassemble the valve to the extent possible and wrap all but the joint with a wet rag to act as a heat sink.

NOTE

If interconnecting tubing was removed with a component, braze tubing to the new components before installation.

- (3) Position component or assembly into place.

WARNING

Never use a heating torch on any part that contains refrigerant. Heat may cause the refrigerant to decompose and release irritating, toxic, and corrosive gases. All refrigerant must be discharged from the system and the entire system must be purged with dry nitrogen before beginning any brazing operation.

CAUTION

- **If heat is applied slowly, or only on one side, the entire component or length of tubing will be heated and filler alloy in adjacent joints may also be melted.**
 - **Brazing a joint without nitrogen flowing through the tubing, will cause deposits to form on the inside of the tube and may obstructions in the refrigeration system or equipment damage.**
- (4) Check that the system is being purged (para 5-9) and apply sufficient heat uniformly around the joint to quickly melt the filler alloy. Remove heat and stop purging (para 5-9) as soon as brazing is completed.

5-11. LEAK TESTING THE REFRIGERANT SYSTEM.

This task covers: Testing

INITIAL SETUPTools:

Nitrogen Regulator
5, Section III, Appendix B

General Safety Instructions:

WARNING

Equipment Conditions:

Service manifold installed (para 5-7).

Materials/Parts:

Refrigerant R-134a
12, Appendix E
Nitrogen
11, Appendix E

- Never pressurize refrigerant lines with oxygen, mixture with oil could cause an explosion.
- The pressure in a nitrogen cylinder can exceed 2000 psi. A nitrogen pressure regulator should be used at all times to avoid personal injury.
- Nitrogen is an inert gas that can cause suffocation and must be discharged in a well ventilated area.

Testing.**NOTE**

- To perform leak test, it is necessary that the system be pressurized with a proportion of refrigerant gas.
 - The electronic gas tester is highly sensitive to the presence of a minute quantity of gas in the air, and is quite effective in the detection of small leaks. However, due to rapid dispersion of refrigerant gas into surrounding air, difficulty may be encountered in pinpointing large leaks. The detector must be used in a well ventilated area but draft free area. Use procedures contained in TM 9-4940-435-14, "Leak Detector, Refrigerant Gas".
- (1) To pressurize a system that has some refrigerant charge.
 - (a) Connect the charge hose to a refrigerant cylinder containing refrigerant R-134a set to deliver gas only.
 - (b) Check that service manifold vacuum valve is closed.
 - (c) Open the service manifold compound gage, pressure gage, and charge valves.
 - (d) Open refrigerant cylinder valve and pressurize system to 100 psi (7.1 kg/cm²).

- (2) To pressurize a system that has been discharged and purged.
 - (a) Connect the charge hose to a refrigerant cylinder containing refrigerant R-134a set to deliver gas only.
 - (b) Check that service manifold vacuum valve is closed.
 - (c) Open the service manifold compound gage, pressure gage, and charge valves.
 - (d) Open refrigerant cylinder valve and pressurize system to 40-50 psi (2.8-3.5 kg/cm²).
 - (e) Close service manifold valves and refrigerant cylinder valve.
 - (f) Disconnect charge hose from the refrigerant cylinder and connect it to a nitrogen regulator and nitrogen cylinder.
 - (g) Open the service manifold compound gage, pressure gage, and charge valves.
 - (h) Open nitrogen cylinder valve and pressurize system to 350 psi (24.7 kg/cm²).
- (3) Test for leaks at all points of possible leakage using a refrigerant gas leak detector. If a leak is found, take necessary steps to replace damaged components or repair leak.
- (4) If no leak was found and refrigerant only was used to pressurize the system, check refrigeration unit charge (para 5-13).
- (5) If no leak was found and nitrogen was used to pressurize the system, discharge (para 5-8), evacuate (para 5-12), and charge (para 5-13) the refrigeration unit.

5-12. EVACUATING THE REFRIGERANT SYSTEM.

This task covers: Evacuate

INITIAL SETUP

Equipment Conditions:

Refrigerant system discharged (para 5-8).

Evacuate. The refrigeration system must be evacuated to remove all moisture and non-condensables before it is charged.

- (1) Check that new dehydrator was installed. If not, install one (para 5-15).
- (2) Check that service manifold charge valve is closed.

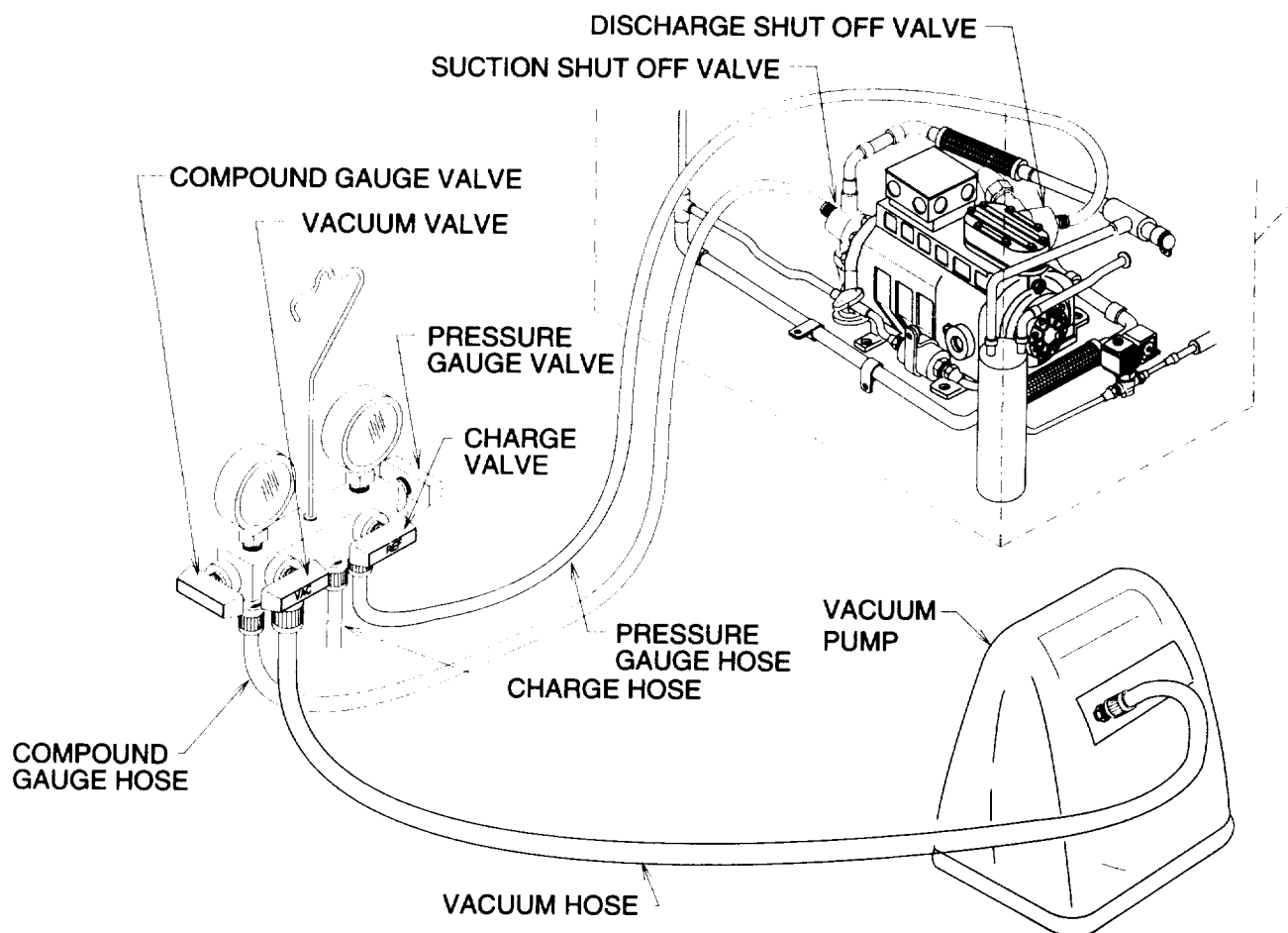


Figure 5-8. Evacuation of Refrigerant System

- (3) Connect the vacuum hose to vacuum pump and start pump.
- (4) Open service manifold high pressure gauge, compound gauge, and vacuum valves.
- (5) Run vacuum pump until at least 29 inches of mercury is measured on compound gage. Continue running vacuum pump for one more hour, while observing the compound gauge. If gage needle moves back and forth, you have a leak which must be located and corrected (para 5-10).

NOTE

Inability to reach and hold 29 inches of mercury may indicate either a leak or a problem with the vacuum pump.

- (6) Close service manifold vacuum valve and stop vacuum pump. Note reading on compound gauge and observe for 10 minutes. If pressure rises, moisture may still be in the system or a leak exists. If pressure rose, repeat evacuation and re-check. If the pressure rise occurs again at the same speed, a leak is in the system and must be found (para 5-11). If the pressure rise was slower the second time, moisture remains in the system and the evacuation process must be repeated until there is no rise.
- (7) Close service manifold high pressure gauge and compound gauge valves.
- (8) Disconnect the vacuum hose from vacuum pump.

NOTE

FOLLOW-ON MAINTENANCE:
Charge the refrigeration system (para 5-13).

5-13. CHARGING THE REFRIGERANT SYSTEM.

 This task covers: a. Full Charge b. Partial Charge

INITIAL SETUPEquipment Conditions:

Service manifold installed (para 5-7).
 Refrigerant system evacuated (para 5-12).

Materials/Parts:

Refrigerant R-134a
 12, Appendix E

General Safety Instructions:**WARNING**

- **Dangerous chemical refrigerant under pressure is used in the operation of this equipment. Use great care to avoid contact with liquid refrigerant.**
- **Sudden and irreversible tissue damage can result from freezing. Wear gloves and a face protector or safety glasses in any situation where skin or eye contact with refrigerant is possible.**
- **Heat may cause the refrigerant to decompose and release irritating, toxic, and corrosive gases. Prevent contact of refrigerant with flame or hot surfaces.**
- **Never introduce high discharge pressure into a refrigerant cylinder. This can cause the cylinder to rupture and injure personnel.**

a. Full Charge.**CAUTION**

The system must be evacuated before charging. Moisture in the system will prevent the refrigeration unit from operating properly.

- (1) Connect the charge hose to a tank containing refrigerant R-134a set to deliver gas and the vacuum hose to reclaim unit.
- (2) Check that compound gauge and pressure gauge valves are closed.
- (3) Open vacuum and charge valves.
- (4) Open refrigerant tank valve. Operate reclaim unit for 3 to 5 seconds to purge hoses.
- (5) Close refrigerant tank, vacuum, and charge valves then stop reclaim unit.

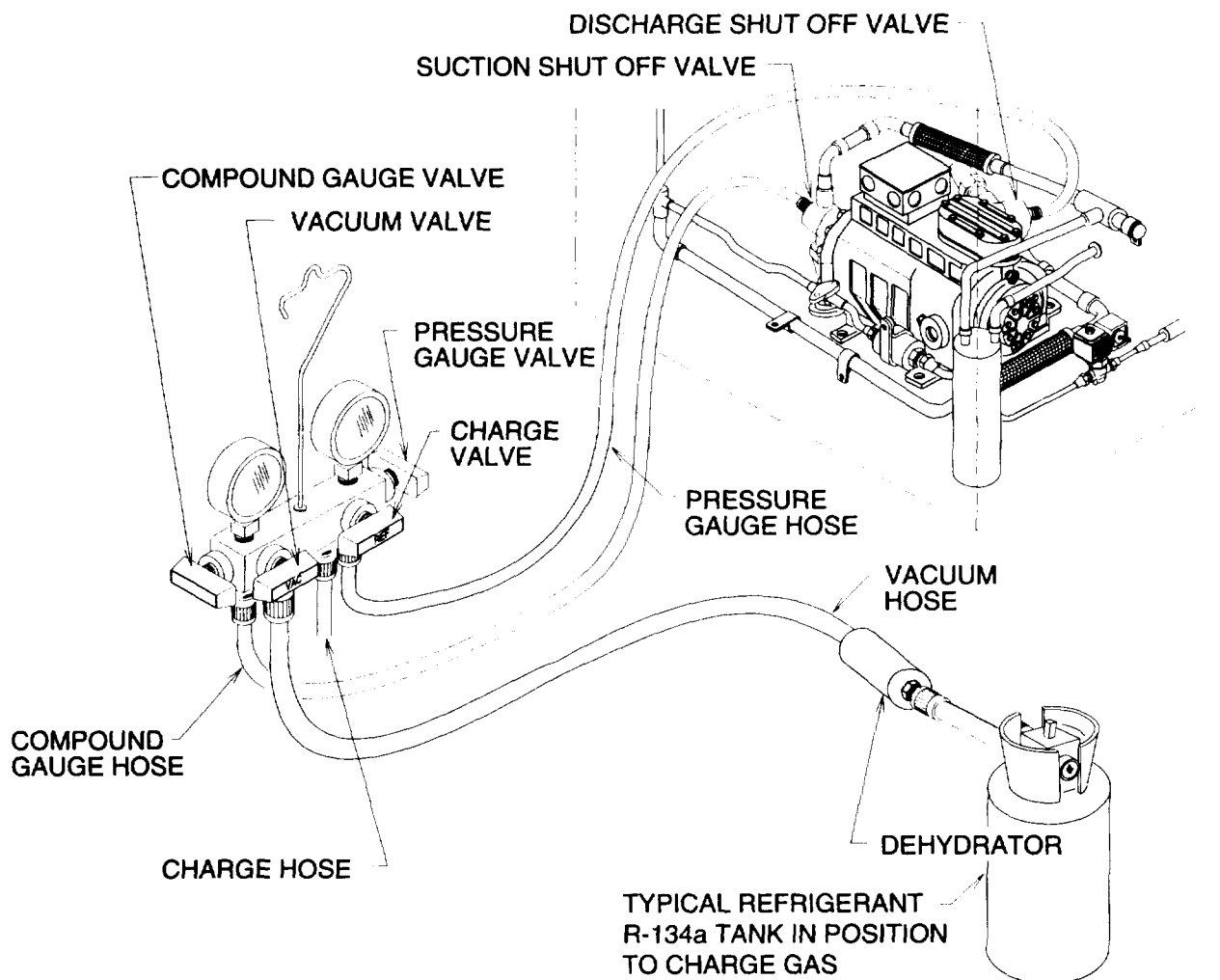


Figure 5-9. Refrigerant Charging (total System)

- (6) Set refrigerant tank to deliver liquid only.
- (7) Place refrigerant tank on an accurate scale to measure and record weight.

CAUTION

Never introduce liquid refrigerant into the suction shut off valve. This can cause damage to the compressor.

- (8) Open refrigerant tank, pressure gauge, and charge valves. Allow liquid refrigerant to enter system until tank weight has decreased by 15 pounds (6.8 kg) or until system pressure has equalized, whichever occurs first.

5-13. CHARGING THE REFRIGERANT SYSTEM. - Continued

- (9) Close refrigerant tank, charge, and pressure gauge valves.

NOTE

If 15 pounds (6.8 kg) full charge was obtained, skip steps (10) through (15).

- (10) Connect power at power source.
- (11) Turn refrigeration unit on (para 4-7) and operate at desired temperature setting.
- (12) Set refrigerant tank to deliver gas only.
- (13) Check that all service manifold valves are closed.

WARNING

Never introduce high discharge pressure into a refrigerant tank. This can cause the tank to rupture and injure personnel.

CAUTION

Never introduce liquid refrigerant into the suction shut off valve. This can cause damage to the compressor.

- (14) Open refrigerant tank, compound gauge, and charge valves.
- (15) Monitor weight of the refrigerant tank until total 15 pounds (6.8 kg) charge is obtained. When system is fully charged, immediately close refrigerant tank, compound gauge, and charge valves.
- (16) Run refrigeration unit for 15 minutes and observe sight glass through left side condenser door.
- (a) Green or chartreuse center means refrigerant moisture content is acceptable.
- (b) Yellow center means there is too much moisture in system. Discharge (para 5-8), replace dehydrator (para 5-15), leak check (para 5-11), evacuate (para 5-12), and charge again.
- (17) Be sure all service manifold valves are closed.
- (18) Shut off refrigeration unit (para 2-7).

b. Partial Charge.

- (1) Connect the charge hose to a tank containing refrigerant R-134a set to deliver gas and the vacuum hose to reclaim unit.
- (2) Check that compound gauge and pressure gauge valves are closed.
- (3) Open vacuum and charge valves.
- (4) Open refrigerant tank valve. Operate reclaim unit for 3 to 5 seconds to purge hoses.

- (5) Close refrigerant tank, vacuum, and charge valves then stop reclaim unit.
- (6) Connect power at power source.
- (7) Turn refrigeration unit on (para 4-7) and operate at desired temperature setting.
- (8) Set refrigerant tank to deliver gas only.
- (9) Check that all service manifold valves are closed.

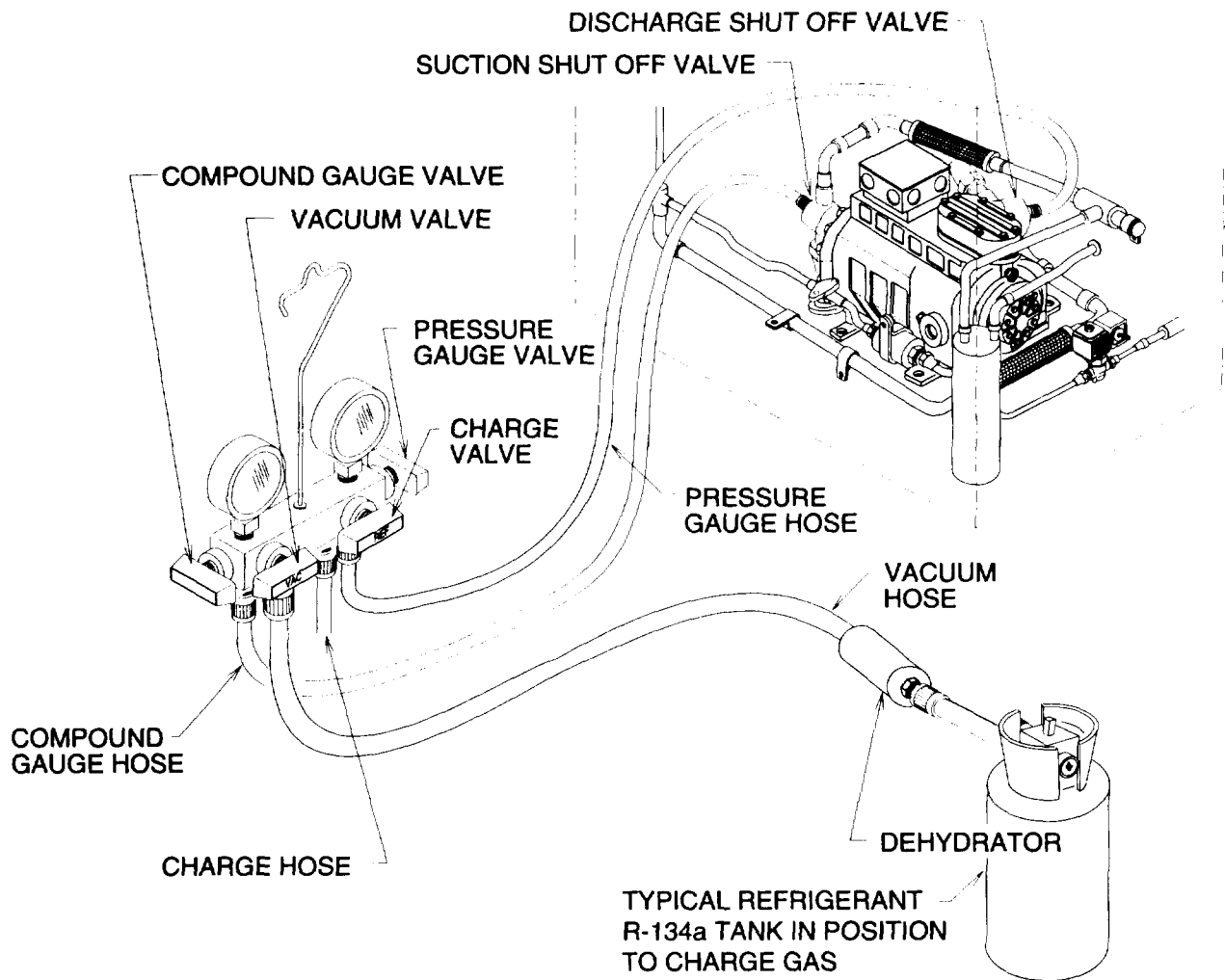


Figure 5-10. Refrigerant Charging (Partial System/Small Quantity Charge)

5-13. CHARGING THE REFRIGERANT SYSTEM. - Continued**WARNING**

Never introduce high discharge pressure into a refrigerant tank. This can cause the tank to rupture and injure personnel.

CAUTION

Never introduce liquid refrigerant into the suction shut off valve. This can cause damage to the compressor.

- (10) Open refrigerant tank, compound gauge, and charge valves.
- (11) Run refrigeration unit for 15 minutes and observe sight glass through left side condenser door.
 - (a) Green or chartreuse center means refrigerant moisture content is acceptable.
 - (b) Yellow center means there is too much moisture in system. Discharge (para 5-8), replace dehydrator (para 5-15); leak check (para 5-11), evacuate (para 5-12), and charge again.
 - (c) Milky white or bubbly liquid means system has low charge.
 - (d) Clean bubble free liquid around center means the system is fully charged.

CAUTION

Never introduce liquid refrigerant into the low pressure (suction) charging valve. This can cause damage to the compressor.

- (12) If charge is low, set refrigerant tank to deliver gas only.

WARNING

Never introduce high discharge pressure into a refrigerant cylinder. This can cause the cylinder to rupture and injure personnel.

- (13) Check that pressure gauge valve is closed.
- (14) Open refrigerant tank, compound gauge, and charge valves.
- (15) Charge until sight glass remains clear and bubble free for 15 minutes.
- (16) When system is fully charged, immediately close refrigerant tank, compound gauge, and charge valves.
- (17) Shut off refrigeration unit (para 2-7).

NOTE

FOLLOW-ON MAINTENANCE:
Remove service manifold (para 5-7).

5-14. REFRIGERANT SYSTEM PRESSURE CHECK.

This task covers: Testing

INITIAL SETUP

Equipment Conditions:

Service manifold installed (para 5-7).

Testing.

- (1) Check that all four service manifold valves are closed.
- (2) Service manifold compound and pressure gauges should indicate the same pressure. Check the reading with the appropriate column in Table 5-1. If the system is even partially charged, the pressure should be approximately equal to that shown in the table for the appropriate ambient temperature. If the pressure is considerably less than shown in the table, the system does not contain enough refrigerant to continue the pressure check. Leak test the refrigeration system (para 5-11).
- (3) Turn the refrigeration unit on (para 4-7) and operate at desired setting.
- (4) With the refrigeration unit operating, allow service manifold gauges to stabilize. Compare readings with those listed in Table 5-1.
 - (a) If discharge and suction pressure are at, or near, the same value, defrost solenoid valve (L2) or compressor (B1) failure is indicated.
 - (b) If discharge pressure is low and suction pressure is normal, a low refrigerant charge is indicated.
 - (c) If discharge pressure is normal and suction pressure is either high, or low, failure of the expansion valve is indicated.
 - (d) If discharge pressure is high and suction pressure is normal, refrigerant overcharge is indicated.
- (5) When pressure tests are completed, turn the refrigeration unit off (para 2-7) and disconnect power.

Table 5-1. Pressure Temperature Relationship of Saturated Refrigerant R-134a

Temperature		Pressure	
Deg F	Deg C	psia	kg/cm ²
-20	-28.88	12.95	5.87
-18	-27.77	13.63	6.18
-16	-26.66	14.35	6.50
-14	-25.55	15.09	6.84
-12	-24.44	15.87	7.19
-10	-23.33	16.67	7.56
-8	-22.22	17.51	7.94
-6	-21.11	18.38	8.33
-4	-20.00	19.29	8.74

Temperature		Pressure	
Deg F	Deg C	psia	kg/cm ²
-2	-18.88	20.23	9.17
0	-17.77	21.20	9.61
2	-16.66	22.22	10.07
4	-15.55	23.27	10.55
6	-14.44	24.35	11.04
8	-13.33	25.48	11.55
10	-12.22	26.65	12.08
12	-11.11	27.86	12.63
14	-10.00	29.11	13.20

5-14. REFRIGERANT SYSTEM PRESSURE CHECK. - Continued

Table 5-1. Pressure Temperature Relationship of Saturated Refrigerant R-134a - Continued

Temperature		Pressure	
Deg F	Deg C	psia	kg/cm ²
16	-8.88	30.41	13.79
18	-7.77	31.75	14.40
20	-6.66	33.14	15.03
22	-5.55	34.57	15.68
24	-4.44	36.05	16.35
26	-3.33	37.58	16.78
28	-2.22	39.16	17.76
30	-1.11	40.79	18.50
32	0	42.47	19.26
34	1.11	44.21	20.05
36	2.22	45.99	20.86
38	3.33	47.84	21.69
40	4.44	49.74	22.56
42	5.55	51.70	23.45
44	6.66	53.71	24.36
46	7.77	55.79	25.30
48	8.88	57.93	26.27
50	10	60.13	27.27
52	11.11	62.39	28.29
54	12.22	64.71	29.35
56	13.33	67.11	30.44
58	14.44	69.57	31.55
60	15.55	72.09	32.69
62	16.66	74.69	33.87
64	17.77	77.36	35.08
66	18.88	80.09	36.32
68	20	82.90	37.60
70	21.11	85.79	38.91
72	22.22	88.75	40.25
74	23.33	91.79	41.63
76	24.44	94.90	43.04
78	25.55	98.09	44.49
80	26.66	101.37	45.98
82	27.77	104.73	47.50
84	28.88	108.16	49.06
86	30	111.69	50.66
88	31.11	115.30	52.16

Temperature		Pressure	
Deg F	Deg C	psia	kg/cm ²
90	32.22	118.99	53.97
92	33.33	122.78	55.69
94	34.44	126.65	57.44
96	35.55	130.62	59.24
98	36.66	134.68	61.08
100	37.77	138.83	62.59
102	38.88	143.07	64.86
104	40	147.42	66.86
106	41.11	151.86	68.88
108	42.22	158.40	71.84
110	43.33	161.04	73.04
112	44.44	165.79	75.20
114	45.55	170.64	77.40
116	46.66	175.59	79.64
118	47.77	180.65	82.58
120	48.88	185.82	84.28
122	50	191.11	86.68
124	51.11	196.50	89.13
126	52.22	202.00	91.62
128	53.33	207.62	94.17
130	54.44	213.36	96.77
132	55.55	219.22	99.43
134	56.66	225.19	102.14
136	57.77	231.29	104.91
138	58.88	237.51	107.73
140	60	243.86	110.06
142	61.11	250.33	113.54
144	62.22	256.94	116.54
146	63.33	263.67	119.59
148	64.44	270.54	122.71
150	65.55	277.54	125.89
152	66.66	284.67	129.12
154	67.77	291.95	132.42
156	68.88	299.37	135.79
158	70	306.64	139.08
160	71.11	314.64	142.71

Table 5-2. Nominal Operating Pressure At Suction And Discharge Shut Off Valves

Air Temperature Entering Evaporator Coil	Air Temperature Entering Condenser Coil 110° F (43° C)
0° F (-18° C)	Suction 1 psi (7 kPa) Discharge 177 psi (1221 kPa)
35° F (2° C)	Suction 10 psi (69 kPa) Discharge 199 psi (1373 kPa)

NOTE

FOLLOW-ON MAINTENANCE:
Remove service manifold (para 5-7).

5-15. DEHYDRATOR REPLACEMENT.

This task covers: a. Removal b. Installation

INITIAL SETUP

Materials/Parts:

- Lock Washers (3)
1, Appendix G
- Self Locking Nut
12, Appendix G

Equipment Conditions:

- Refrigeration system discharged (para 5-8).
- Left side condenser door open.

a. Removal.

- (1) Loosen two flare nuts (1).

NOTE

Note flow direction prior to removal.

- (2) Remove self locking nut (2), bolt (3), clamp (4), and dehydrator (5). Discard self locking nut.
- (3) If filter drier bracket (6) is damaged, remove three bolts (7), lock washers (8) and bracket. Discard lock washers.

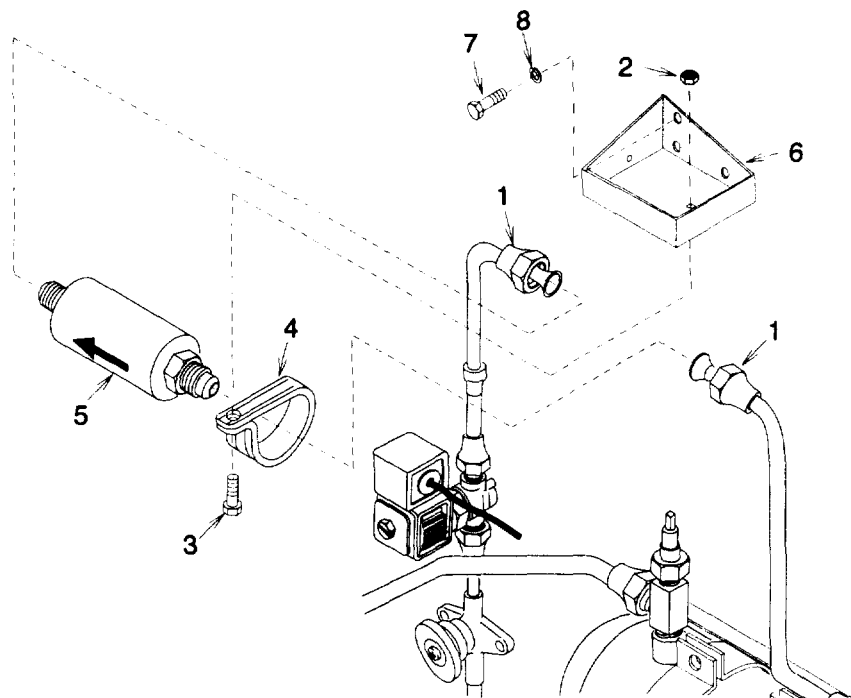


Figure 5-11. Dehydrator

b. Installation.

- (1) If removed, install bracket (6), three new lock washers (8) and bolts (7).

NOTE

Do not remove dehydrator protective caps until just before installation. This will minimize the risk of contaminating the dehydrator. Be sure to observe flow direction noted during removal.

- (2) Install new dehydrator (5), clamp (4), bolt (3), and new self locking nut (2).
- (3) Tighten two flare nuts (1).

NOTE

FOLLOW-ON MAINTENANCE:

Close left side condenser door.

Leak check (para 5-11), evacuate (para 5-12), and charge (para 5-13) the refrigeration system.

5-16. COMPOUND GAGE REPLACEMENT.

This task covers: a. Removal b. Installation

INITIAL SETUP

Materials/Parts:

Self Locking Nuts (3)
8, Appendix G
Anti-Seize Tape
22, Appendix E

Equipment Conditions:

Refrigeration system discharged (para 5-8).
Control panel cover open.
Left side condenser door open.

a. Removal.

- (1) Loosen flare nut (1) and move copper tubing (2) over to one side being careful not to bend or kink tubing.
- (2) Remove coupling (3).
- (3) Remove three self locking nuts (4), bolts (5) and compound gage (6). Discard self locking nuts.

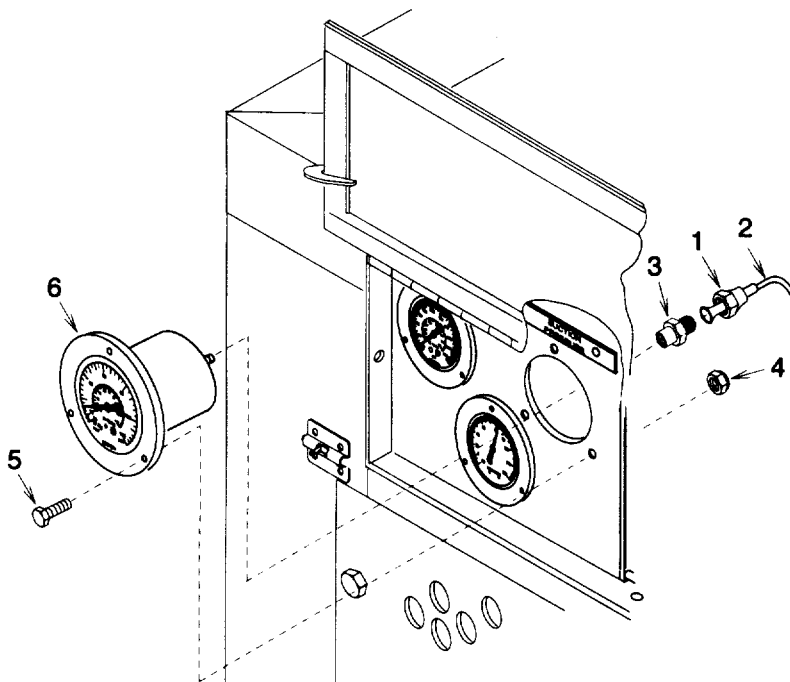


Figure 5-12. Compound Gage

b. Installation.

- (1) Wrap anti-seize tape around compound gage (6) connector threads.
- (2) Install compound gage (6), three bolts (5), and new self locking nuts (4).
- (3) Install coupling (3).
- (4) Aline copper tubing (2) and connect flare nut (1) to coupling (3).

NOTE

FOLLOW-ON MAINTENANCE:

Close left side condenser door.

Close control panel cover.

Replace dehydrator (para 5-15).

Leak check (para 5-11), evacuate (para 5-12), and charge (para 5-13) the refrigeration system.

5-17. PRESSURE GAGE REPLACEMENT.

This task covers: a. Removal b. Installation

INITIAL SETUP

Materials/Parts:

Self Locking Nuts (3)
8, Appendix G
Anti-Seize Tape
22, Appendix E

Equipment Conditions:

Refrigeration system discharged (para 5-8).
Control panel cover open.
Left side condenser door open.

a. Removal.

- (1) Loosen flare nut (1) and move copper tubing (2) over to one side being careful not to bend or kink tubing.
- (2) Remove coupling (3).
- (3) Remove three self locking nuts (4), bolts (5) and pressure gage (6). Discard self locking nuts.

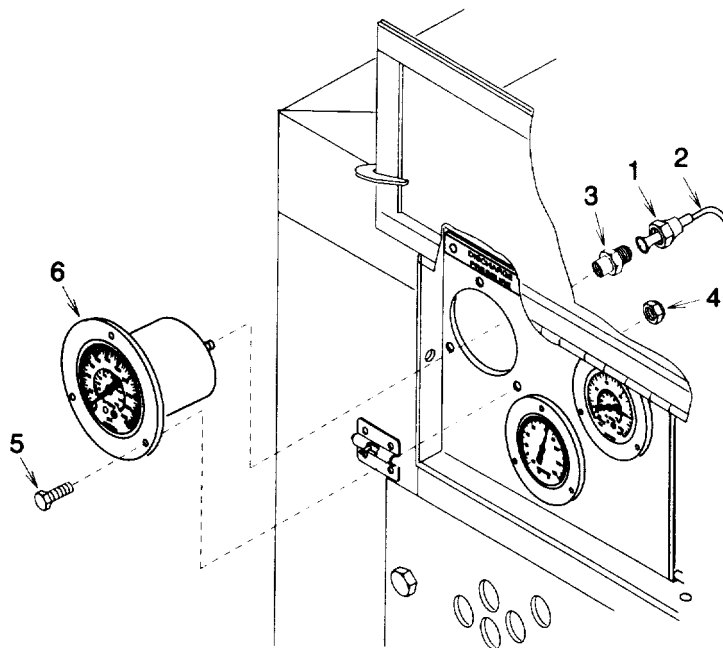


Figure 5-13. Pressure Gage

b. Installation.

- (1) Wrap anti-seize tape around pressure gage (6) connector threads.
- (2) Install pressure gage (6), three bolts (5), and new self locking nuts (4).
- (3) Install coupling (3).
- (4) Aline copper tubing (2) and connect flare nut (1) to coupling (3).

NOTE

FOLLOW-ON MAINTENANCE:

Close left side condenser door.

Close control panel cover.

Replace dehydrator (para 5-15).

Leak check (para 5-11), evacuate (para 5-12), and charge (para 5-13) the refrigeration system.

5-18. STRAINER REPLACEMENT.

This task covers: a. Removal b. Installation

INITIAL
SETUP

Materials/Parts:

Self Locking Nut
12, Appendix G

Equipment Conditions:

Refrigeration system discharged (para 5-8).
Front bottom doors open.

a. Removal.

- (1) Loosen two flare nuts (1).

NOTE

Note flow direction prior to removal.

- (2) Remove self locking nut (2), bolt (3), clamp (4), and strainer (5). Discard self locking nut.

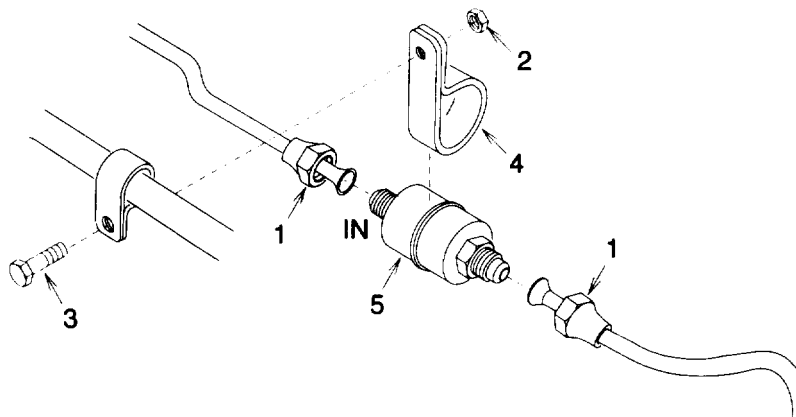


Figure 5-14. Strainer

b. Installation.

NOTE

Be sure to observe flow direction noted during removal.

- (1) Install strainer (5), clamp (4), bolt (3), and new self locking nut (2).
- (2) Tighten two flare nuts (1).

NOTE

FOLLOW-ON MAINTENANCE:

Close front bottom doors.
Replace dehydrator (para 5-15).

Leak check (para 5-11), evacuate (para 5-12), and charge (para 5-13) the refrigeration system.

5-19. RECEIVER REPLACEMENT.

This task covers: a. Removal b. Installation

INITIAL SETUP

Materials/Parts:

- Self Locking Nuts (2)
15, Appendix G
- Anti-Seize Tape
22, Appendix E
- Lubricating Oil
21, Appendix E

Equipment Conditions:

Refrigeration system discharged (para 5-15).
Side condenser doors open.

General Safety Instructions:



Compressor lubricating oil used in this refrigeration system is caustic. Wear gloves and a face protector or safety glasses in any situation where skin or eye contact is possible. If oil does contact skin, wash with soap and water.

a. Removal.

- (1) Remove two isolation valve caps (1).
- (2) Loosen two flare nuts (2) and move copper tubing (3) away from isolation valve (4) being careful not to bend or kink tubing.

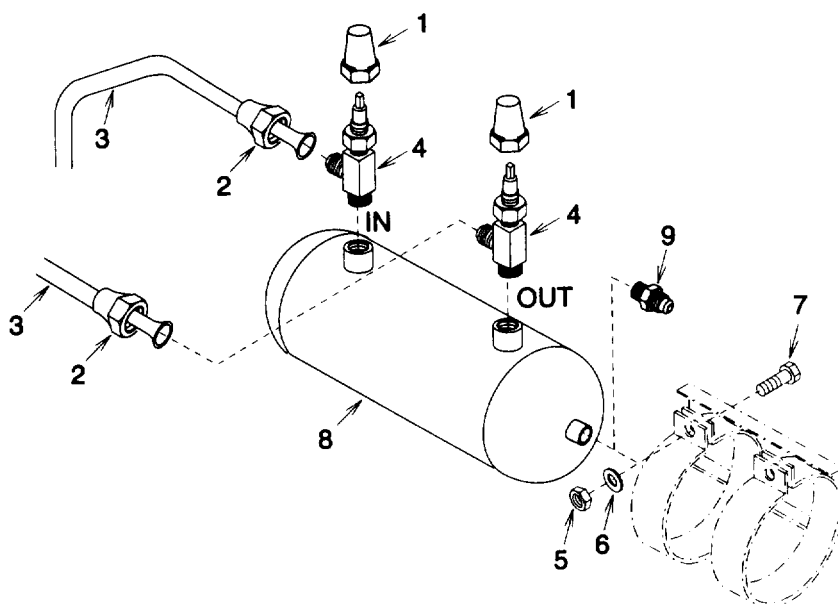


Figure 5-15. Receiver

5-19. RECEIVER REPLACEMENT. - Continued

- (3) Remove two isolation valves (4).

NOTE

Note flow direction prior to removal.

- (4) Remove two self locking nuts (5), flat washers (6), bolts (7), and receiver (8). Discard self locking nuts.
- (5) Remove fusible plug (9).

b. Installation.

- (1) Lightly coat fusible plug (9) copper gasket with lubricating oil.
- (2) Install fusible plug (9) and tighten to between 25 and 30 ft-lb (34 and 41 Nm).
- (3) Wrap anti-seize tape around two isolation valve (4) bottom threads.

NOTE

Be sure to observe flow direction noted during removal.

- (4) Install receiver (8), two bolts (7), flat washers (6), and new self locking nuts (5).
- (5) Install two isolation valves (4). Be sure valves are turned toward copper tubing (3) when tightened.
- (6) Aline copper tubing (3) and connect two flare nuts (2) to isolation valves (4).
- (7) Be sure two isolation valves (4) are open and install two isolation valve caps (1).

NOTE**FOLLOW-ON MAINTENANCE:**

Close side condenser doors.

Replace dehydrator (para 5-15).

Leak check (para 5-11), evacuate (para 5-12), and charge (para 5-13) the refrigeration system.

5-20. CONDENSER COIL REPLACEMENT.

This task covers: a. Removal b. Installation

INITIAL
SETUP

Materials/Parts:

- Self Locking Nuts (8)
17, Appendix G
- Self Locking Nut (Pressure Regulator Clamp)
12, Appendix G
- Self Locking Nuts (4) (Wire Harness Clamps)
12, Appendix G
- Lock Washers (3)
1, Appendix G

Tools:

- Gloves
1, Section III, Appendix B

Equipment Conditions:

- Refrigeration system discharged (para 5-8) and purged (para 5-9).
- Both side condenser doors open.
- Condenser guard removed (para 4-19).

a. Removal.

- (1) Remove self locking nut (1) and bolt (2). Discard self locking nut.
- (2) De-braze two fittings (3) from condenser coil (4) (para 5-10).



Coil fins are sharp and can cut hands or fingers. Wear gloves to prevent personal injury when handling coil.

- (3) Remove eight self locking nuts (5), bolts (6), and condenser coil (4). Discard self locking nuts.
- (4) If condenser shroud (7) must be replaced, remove fan drive shaft (para 5-5).
- (5) Remove four self locking nuts (8) and bolts (9). Discard self locking nuts.
- (6) Remove three bolts (10), lock washers (11), and condenser shroud (7). Discard lock washers.

b. Installation.

- (1) If condenser shroud (7) was removed, install shroud, align three clamps (12) and install new lock washers (11) and bolts (10).
- (2) Align four clamps (13) and install four bolts (9) and self locking nuts (8).
- (3) Install fan drive shaft (para 5-5).



Coil fins are sharp and can cut hands or fingers. Wear gloves to prevent personal injury when handling coil.

- (4) Install condenser coil (4), eight bolts (6), and new self locking nuts (5).

5-20. CONDENSER COIL REPLACEMENT. - Continued

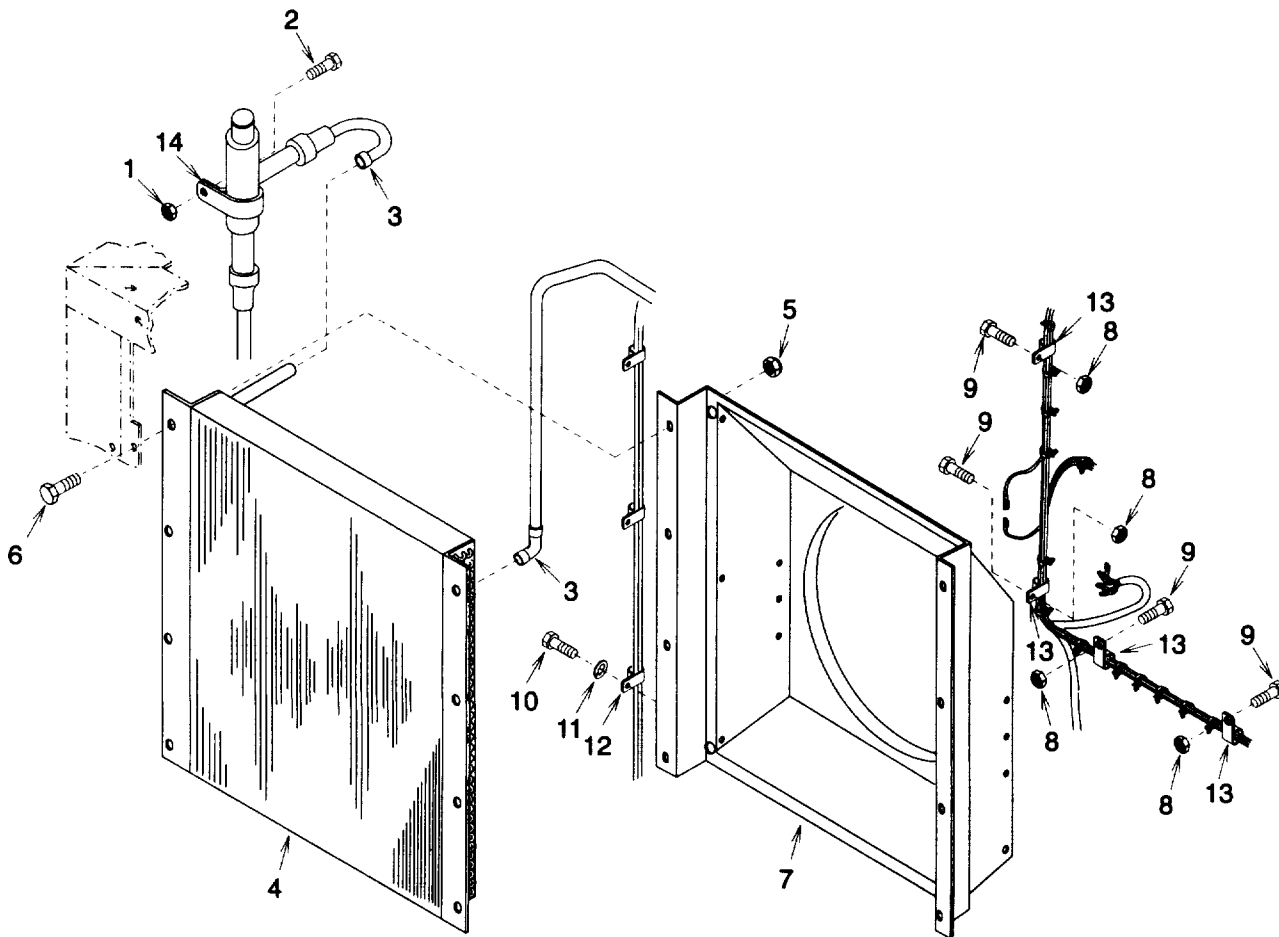


Figure 5-16. Condenser Coil

- (5) Braze two fittings (3) onto condenser coil (4) (para 5-10).
- (6) Aline clamp (14) and install bolt (2) and new self locking nut (1).

NOTE

FOLLOW-ON MAINTENANCE:
 Install condenser guard (para 4-19).
 Close both side condenser doors.
 Replace dehydrator (para 5-15).

Leak check (para 5-11), evacuate (para 5-12), and charge (para 5-13) the refrigeration system.

5-21. PRESSURE REGULATOR VALVE (DISCHARGE) REPLACEMENT.

This task covers: a. Removal b. Installation

INITIAL SETUP

Materials/Parts:

Self Locking Nut
12, Appendix G

Equipment Conditions:

Refrigeration system discharged (para 5-8) and
purged (para 5-9).
Left side condenser door open.

a. Removal.

- (1) De-braze two fittings (1) from pressure regulator valve (2) (para 5-10).
- (2) Remove self locking nut (3), bolt (4), pressure regulator valve (2), and clamp (5). Discard self locking nut.

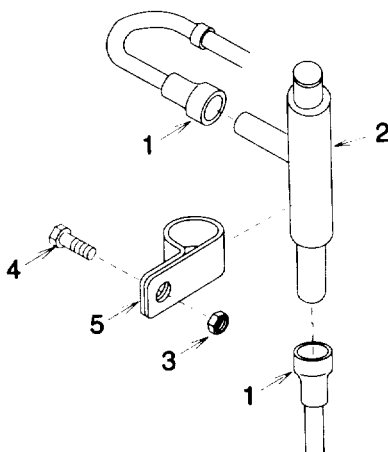


Figure 5-17. Pressure Regulator Valve

5-21. PRESSURE REGULATOR VALVE (DISCHARGE) REPLACEMENT. - Continued

b. Installation.

- (1) Install clamp (5) onto pressure regulator valve (2) and align clamp. Install bolt (4) and new self locking nut (3).
- (2) Braze two fittings (1) onto pressure regulator valve (2) (para 5-10).

NOTE

FOLLOW-ON MAINTENANCE:

Close left side condenser door.

Replace dehydrator (para 5-15).

Leak check (para 5-11), evacuate (para 5-12), and charge (para 5-13) the refrigeration system.

5-22. PRESSURE REGULATOR VALVE (CRANKCASE) REPLACEMENT.

 This task covers: a. Removal b. Installation

INITIAL SETUPMaterials/Parts:

Self Locking Nut
12, Appendix G
Insulation Tape
10, Appendix E

Equipment Conditions:

Refrigeration system discharged (para 5-8) and
purged (para 5-9).
Right side condenser door open.

a. Removal.

- (1) Remove insulation (1).
- (2) De-braze two fittings (2) from pressure regulator valve (3) (para 5-10).
- (3) Remove self locking nut (4), bolt (5), pressure regulator valve (3), and clamp (6). Discard self locking nut.

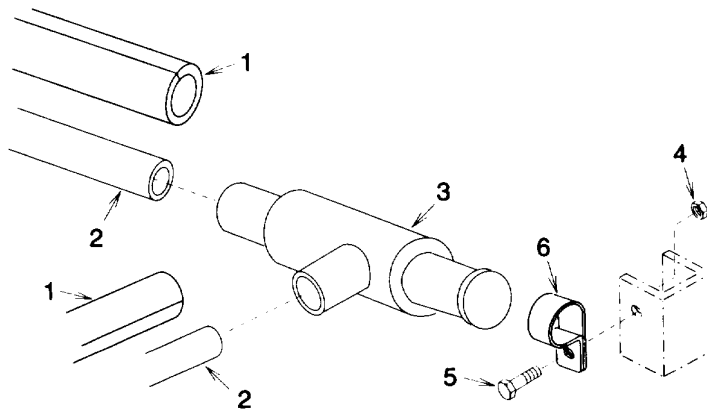


Figure 5-18. Pressure Regulator Valve

b. Installation.

- (1) Install clamp (6) onto pressure regulator valve (3) and align clamp. Install bolt (5) and new self locking nut (4).
- (2) Braze two fittings (2) onto pressure regulator valve (3) (para 5-10).
- (3) Install insulation (1) and wrap with insulation tape.

NOTE

FOLLOW-ON MAINTENANCE:
Close right side condenser door.
Replace dehydrator (para 5-15).
Leak check (para 5-11), evacuate (para 5-12), and charge (para 5-13) the refrigeration system.

5-23. METAL HOSE ASSEMBLY (DISCHARGE) REPLACEMENT.

This task covers: a. Removal b. Installation

INITIAL SETUP

Equipment Conditions:

Refrigeration system discharged (para 5-8) and
purged (para 5-9).

Left side condenser door open.

- a. Removal. De-braze two fittings (1) (para 5-10) and remove metal hose assembly (2).

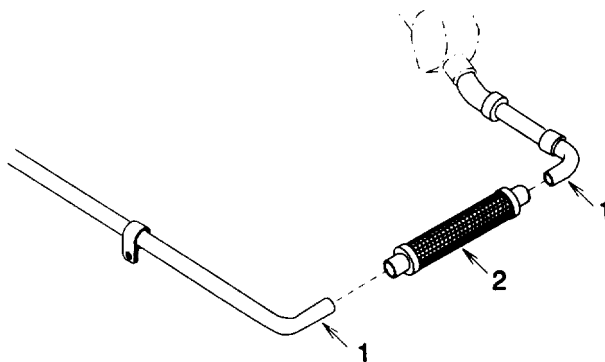


Figure 5-19. Metal Hose Assembly

- b. Installation. Install metal hose assembly (2) and braze two fittings (1) (para 5-10).

NOTE

FOLLOW-ON MAINTENANCE:

Close left side condenser door.

Replace dehydrator (para 5-15).

Leak check (para 5-11), evacuate (para 5-12), and charge (para 5-13) the refrigeration system.

5-24. METAL HOSE ASSEMBLY (SUCTION) REPLACEMENT.

 This task covers: a. Removal b. Installation

INITIAL SETUPMaterials/Parts:

Insulation Tape
10, Appendix E

Equipment Conditions:

Refrigeration system discharged (para 5-8) and
purged (para 5-9).
Right side condenser door open.

a. Removal.

- (1) Remove insulation (1) as necessary.
- (2) De-braze two fittings (2) (para 5-10) and remove metal hose assembly (3).

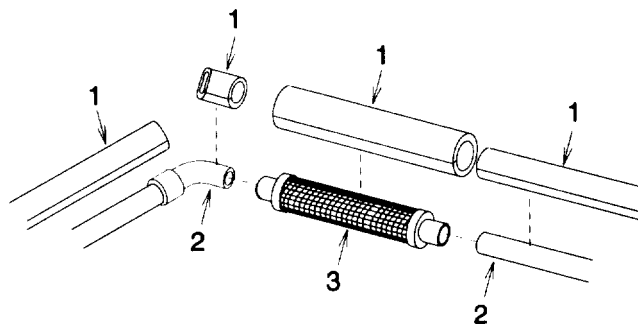


Figure 5-20. Metal Hose Assembly

b. Installation.

- (1) Install metal hose assembly (3) and braze two fittings (2) (para 5-10).
- (2) Install insulation (1) and secure with insulation tape as necessary.

NOTE

FOLLOW-ON MAINTENANCE:
Close right side condenser door.
Replace dehydrator (para 5-15).

Leak check (para 5-11), evacuate (para 5-12), and charge (para 5-13) the refrigeration system.

5-25. STOP VALVE (LIQUID LINE) REPLACEMENT.

 This task covers: a. Removal b. Installation

INITIAL SETUP

Materials/Parts:

Self Locking Nuts (2)
12, Appendix G

Equipment Conditions:

Refrigeration system discharged (para 5-8) and
purged (para 5-9).
Left side condenser door open.

a. Removal.

- (1) De-braze two fittings (1) from stop valve (2) (para 5-10).
- (2) Remove two self locking nuts (3), bolts (4), and stop valve (2). Discard self locking nuts.

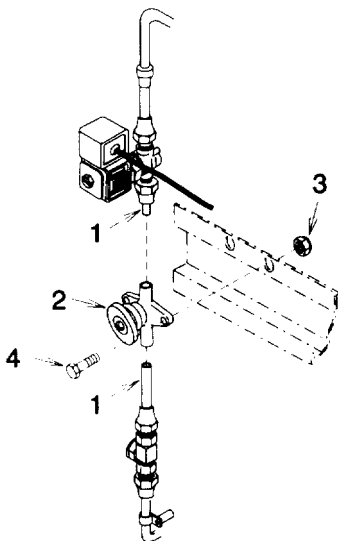


Figure 5-21. Stop Valve

b. Installation.

- (1) Install stop valve (2), two bolts (4) and new self locking nuts (3).
- (2) Braze two fittings (1) onto stop valve (2) (para 5-10).

NOTE

FOLLOW-ON MAINTENANCE:

Close left side condenser door.
Replace dehydrator (para 5-15).

Leak check (para 5-11), evacuate (para 5-12), and charge (para 5-13) the refrigeration system.

5-26. STOP VALVE (DEFROST LINE) REPLACEMENT.

 This task covers: a. Removal b. Installation

INITIAL SETUPMaterials/Parts:

Self Locking Nuts (2)
12, Appendix G

Equipment Conditions:

Refrigeration system discharged (para 5-8) and
purged (para 5-9).
Front bottom doors open.

a. Removal.

- (1) De-braze two fittings (1) from stop valve (2) (para 5-10).
- (2) Remove two self locking nuts (3), bolts (4), and stop valve (2). Discard self locking nuts.

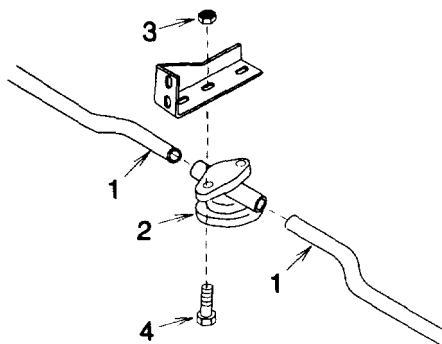


Figure 5-22. Stop Valve

b. Installation.

- (1) Install stop valve (2), two bolts (4) and new self locking nuts (3).
- (2) Braze two fittings (1) onto stop valve (2) (para 5-10).

NOTE**FOLLOW-ON MAINTENANCE:**

Close front bottom doors.
Replace dehydrator (para 5-15).
Leak check (para 5-11), evacuate (para 5-12), and charge (para 5-13) the refrigeration system.

5-27. SIGHT INDICATOR REPLACEMENT.

This task covers: a. Removal b. Installation

INITIAL SETUP

Equipment Conditions:

Refrigeration system discharged (para 5-8).
Left side condenser door open.

- a. Removal. Loosen two flare nuts (1) and remove sight indicator (2).

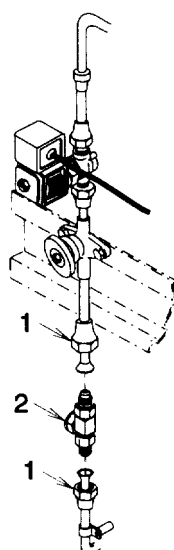


Figure 5-23. Sight Indicator

- b. Installation. Install sight indicator (2), aligned facing the side condenser door, and tighten two flare nuts (1).

NOTE

FOLLOW-ON MAINTENANCE:

Close left side condenser door.

Replace dehydrator (para 5-15).

Leak check (para 5-11), evacuate (para 5-12), and charge (para 5-13) the refrigeration system.

5-28. SOLENOID VALVE L1 (LIQUID LINE) REPLACEMENT.

This task covers: a. Removal b. Installation

INITIAL SETUP

Materials/Parts:

Marker tags (2)
7, Appendix E

Equipment Conditions:

Refrigeration system discharged (para 5-8).
Left side condenser door open.

a. Removal.

- (1) Tag and disconnect wire leads (1).

NOTE

Solenoid coil mounting hardware is supplied with solenoid valve.

- (2) Remove screw (2), lock washer (3), data plate (4), and solenoid coil (5).

NOTE

Note flow direction prior to removal.

- (3) Loosen two flare nuts (6) and remove solenoid valve (7).

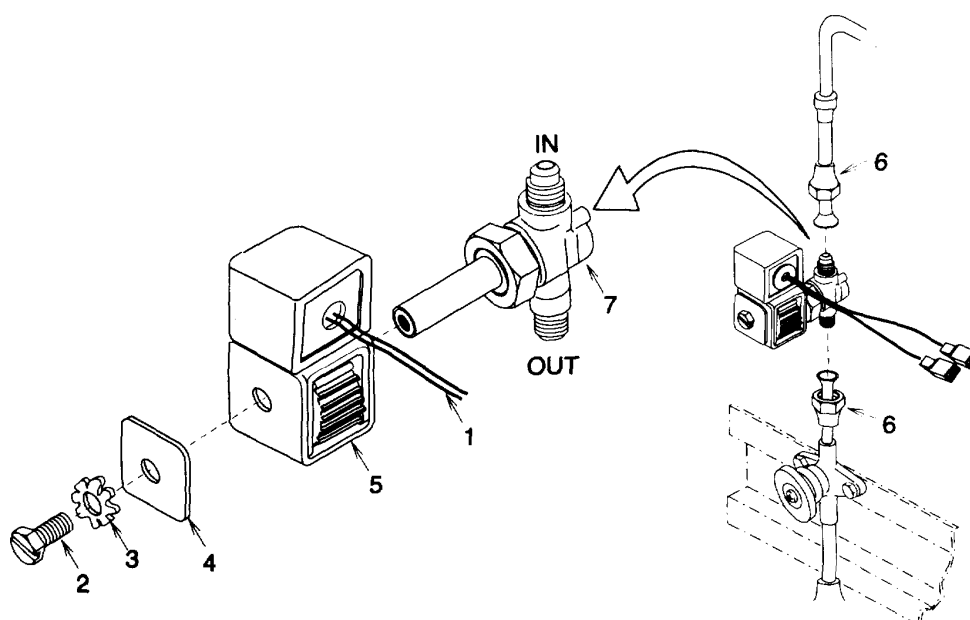


Figure 5-24. Solenoid Valve.

5-28. **SOLENOID VALVE L1 (LIQUID LINE) REPLACEMENT** . - Continued

b. Installation.

NOTE

Be sure to observe flow direction noted during removal.

- (1) Install solenoid valve (7) and tighten two flare nuts (6).
- (2) Install solenoid coil (5), data plate (4), lock washer (3), and screw (2).
- (3) Using tags and wiring diagram (fig. 2-4), connect wire leads (1). Remove tags.

NOTE

FOLLOW-ON MAINTENANCE:

Close left side condenser door.

Replace dehydrator (para 5-15).

Leak check (para 5-11), evacuate (para 5-12), and charge (para 5-13) the refrigeration system.

5-29. SOLENOID VALVE L2 (LIQUID LINE) REPLACEMENT.

This task covers: a. Removal b. Installation

INITIAL SETUP

Materials/Parts:

Marker tags (2)
7, Appendix E

Equipment Conditions:

Refrigeration system discharged (para 5-8).
Left side condenser door open.

a. Removal.

- (1) Tag and disconnect wire leads (1).

NOTE

Solenoid coil mounting hardware is supplied with solenoid valve.

- (2) Remove screw (2), lock washer (3), data plate (4), and solenoid coil (5).

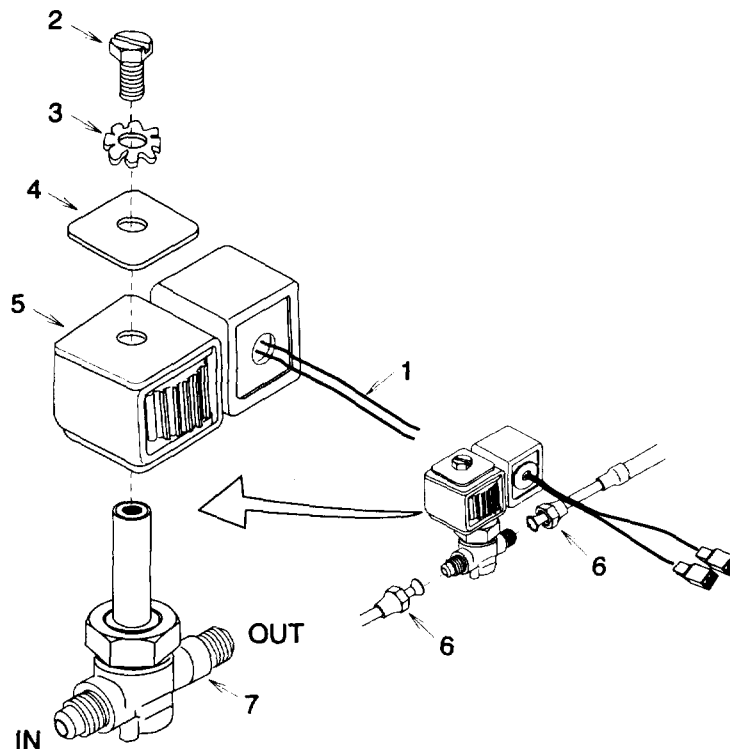


Figure 5-25. Solenoid Valve.

5-29. **SOLENOID VALVE L2 (DEFROST LINE) REPLACEMENT**. - Continued

NOTE

Note flow direction prior to removal.

(3) Loosen two flare nuts (6) and remove solenoid valve (7).

b. Installation.

NOTE

Be sure to observe flow direction noted during removal.

(1) Install solenoid valve (7) and tighten two flare nuts (6).

(2) Install solenoid coil (5), data plate (4), lock washer (3), and screw (2).

(3) Using tags and wiring diagram (fig. 2-4), connect wire leads (1). Remove tags.

NOTE

FOLLOW-ON MAINTENANCE:

Close right side condenser door.

Replace dehydrator (para 5-15).

Leak check (para 5-11), evacuate (para 5-12), and charge (para 5-13) the refrigeration system.

5-30. ISOLATION VALVES REPLACEMENT.

This task covers: a. Removal b. Installation

INITIAL SETUPMaterials/Parts:

Anti-Seize Tape
22, Appendix E

Equipment Conditions:

Refrigeration system discharged (para 5-8).
Side condenser doors open.

a. Removal.

- (1) Remove two isolation valve caps (1).
- (2) Loosen two flare nuts (2) and move copper tubing (3) away from isolation valve (4) being careful not to bend or kink tubing.
- (3) Remove two isolation valves (4).

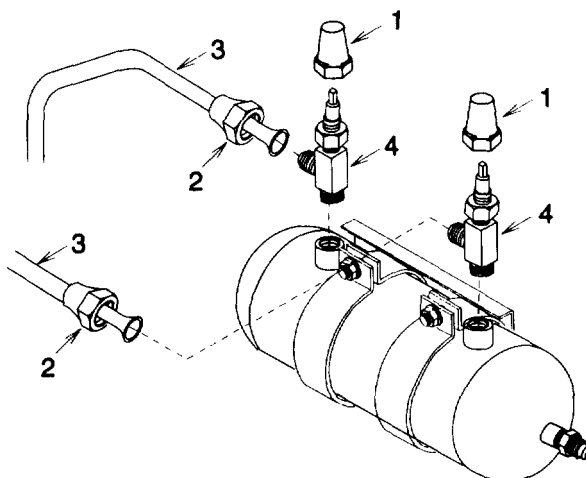


Figure 5-26. Isolation Valves.

5-30. ISOLATION VALVES REPLACEMENT. - Continued

b. Installation.

- (1) Wrap anti-seize tape around two isolation valve (4) bottom threads.
- (2) Install two isolation valves (4). Be sure valves are turned toward copper tubing (3) when tightened.
- (3) Aline copper tubing (3) and connect two flare nuts (2) to isolation valves (4).
- (4) Be sure two isolation valves (4) are open and install two isolation valve caps (1).

NOTE

FOLLOW-ON MAINTENANCE:

Close side condenser doors.

Replace dehydrator (para 5-15).

Leak check (para 5-11), evacuate (para 5-12), and charge (para 5-13) the refrigeration system.

5-31. ACCUMULATOR REPLACEMENT.

This task covers: a. Removal b. Installation

INITIAL SETUP

Materials/Parts:

- Lock Washers (4)
1, Appendix G
- Self Locking Nut
17, Appendix G
- Insulation Tape
10, Appendix E
- Lubricating Oil
21, Appendix E

Equipment Conditions:

- Refrigeration system discharged (para 5-8) and purged (para 5-9).
- Right side condenser door open.

General Safety Instructions:

WARNING

Compressor lubricating oil used in this refrigeration system is caustic. Wear gloves and a face protector or safety glasses in any situation where skin or eye contact is possible. If oil does contact skin, wash with soap and water.

a. Removal.

- (1) Remove insulation (1) as necessary.
- (2) De-braze two fittings (2) from accumulator (3) (para 5-10).

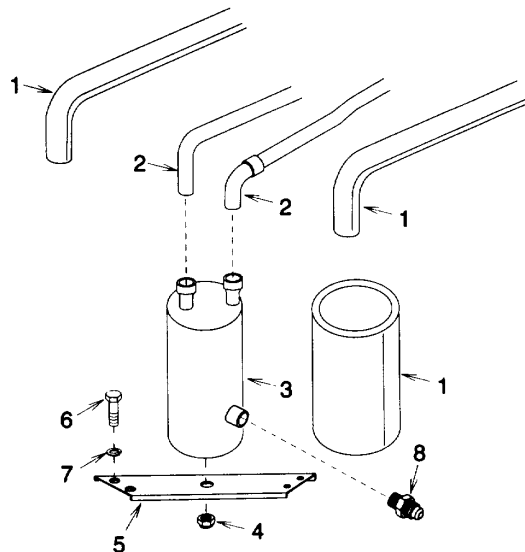


Figure 5-27. Accumulator.

5-31. ACCUMULATOR REPLACEMENT. - Continued

- (3) Remove self locking nut (4) and accumulator (3). Discard self locking nut.
- (4) If channel (5) is to be replaced, remove four bolts (6), lock washers (7), and channel. Discard lock washers.
- (5) Remove fusible plug (8).

b. Installation.

- (1) Lightly coat fusible plug (8) copper gasket with lubricating oil.
- (2) Install fusible plug (8) and tighten to between 25 and 30 ft-lb (34 and 41 Nm).
- (3) If channel (5) was removed, install channel, four new lock washers (7), and bolts (6).
- (4) Install accumulator (3) and new self locking nut (4).
- (5) Braze two fittings (2) onto accumulator (3) (para 5-9).
- (6) Install insulation (1) and secure with insulation tape as necessary.

NOTE**FOLLOW-ON MAINTENANCE:**

Close right side condenser door.

Replace dehydrator (para 5-15).

Leak check (para 5-11), evacuate (para 5-12), and charge (para 5-13) the refrigeration system.

5-32. TUBING AND FITTINGS TESTING, REPAIR, AND REPLACEMENT.

This task covers:	a. Removal	b. Removal	c. Installation
--------------------------	-------------------	-------------------	------------------------

INITIAL SETUP

Equipment Conditions:
Doors, panels, guards open/removed as necessary.

General Safety Instructions:

Materials/Parts:
Silicone RTV

WARNING

High voltage and rotating parts are used in the refrigeration unit. Personal injury can result if power is connected.

20, Appendix E

-
- a. Testing. Leak test the tubing and fittings (para 5-11).

NOTE

Repair consists of replacing damaged or leaking tubing and/or fittings.

- b. Removal.

- (1) Discharge (para 5-8) the refrigeration system.
- (2) If a flare connection was leaking, loosen flare nut and cut the damaged flare off the tubing end.
- (3) Purge (para 5-9) the refrigeration system and de-braze (para 5-10) any fitting or tubing that was leaking or was too short to flare.
- (4) Remove any silicone RTV remaining in evaporator frame grommets.

5-32. TUBING AND FITTINGS TESTING, REPAIR, AND REPLACEMENT . - Continued

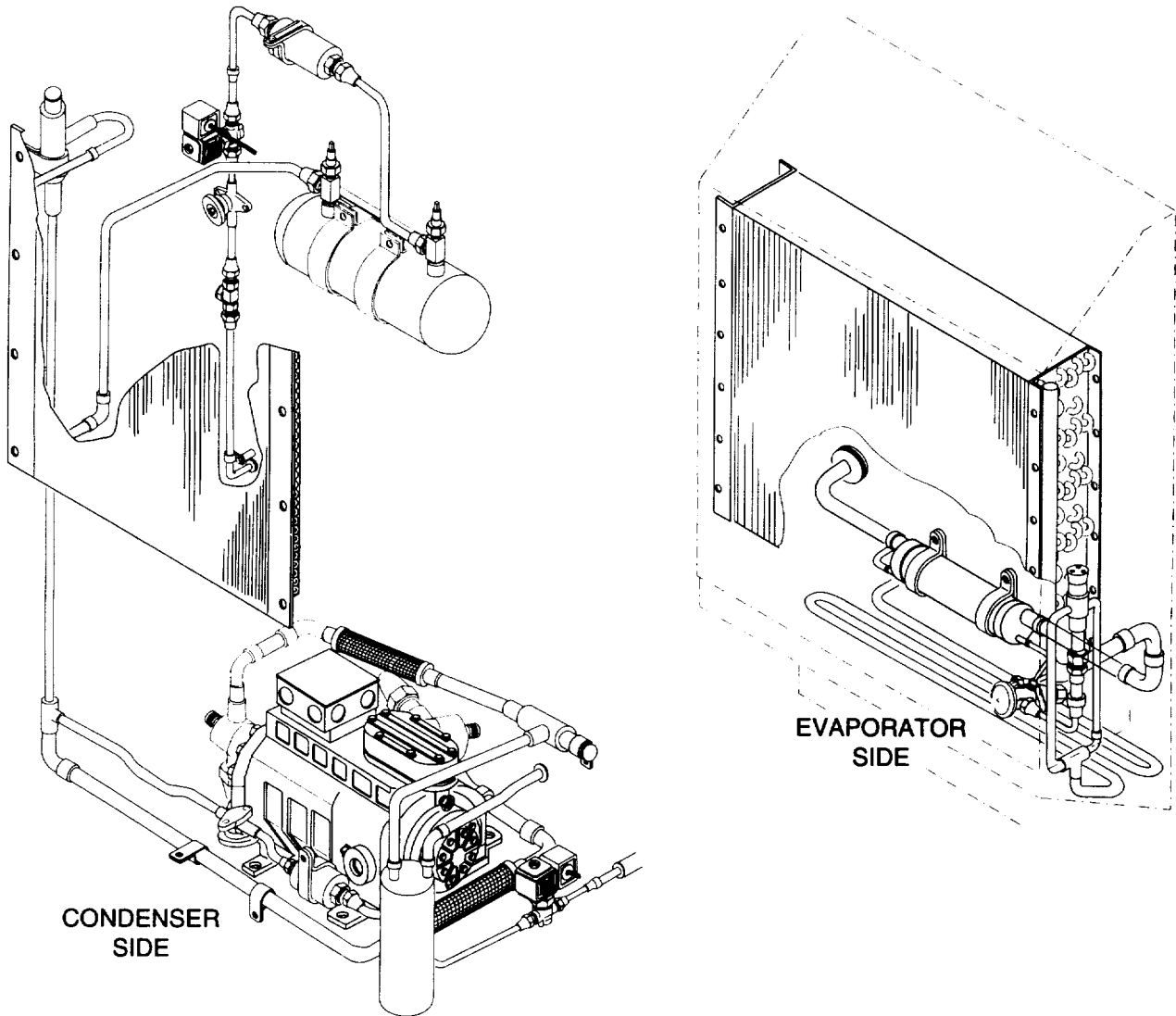


Figure 5-28. Tubing And Fittings

c. Installation.

- (1) Purge (para 5-9) the refrigeration system and braze (para 5-10) any loose tubing or fitting connections.
- (2) Flare tubing end where damaged flare was removed or on end of new tube if it was too short to flare.
- (3) Replace dehydrator (para 5-15).
- (4) Leak check (para 5-11), evacuate (para 5-12), and charge (para 5-13) the refrigeration system.
- (5) Apply silicone RTV into evaporator frame grommets to seal evaporator enclosure.

NOTE

**FOLLOW-ON MAINTENANCE:
Close/install any doors, panels, guards removed.**

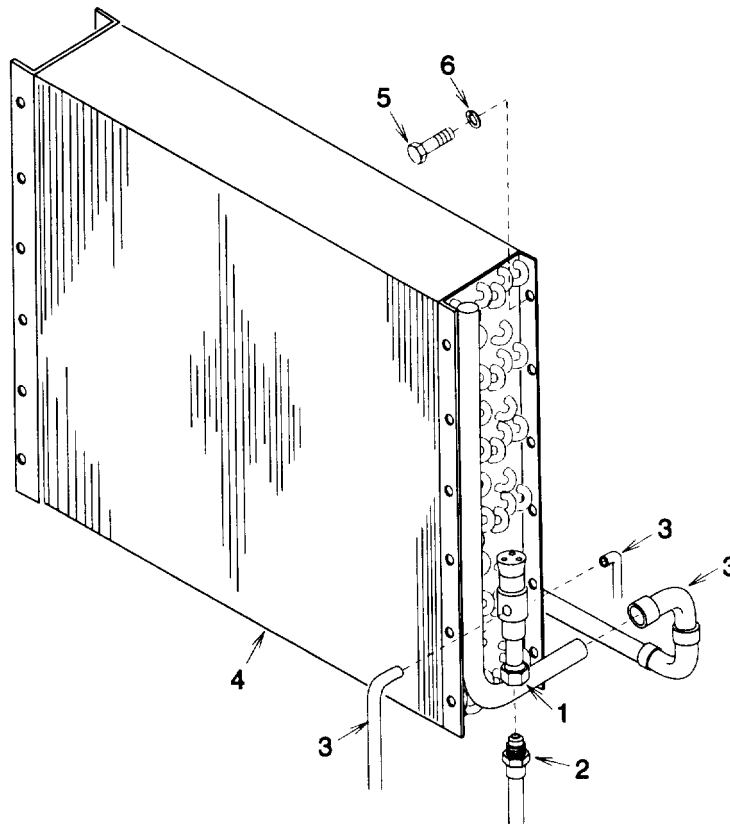


Figure 5-31. Evaporator Coil

NOTE

FOLLOW-ON MAINTENANCE:

Install evaporator coil guard (para 4-18).
 Replace dehydrator (para 5-15).
 Leak check (para 5-11), evacuate (para 5-12), and charge (para 5-13) the refrigeration system.

5-36. DIFFERENTIAL OIL PRESSURE SWITCH S5 REPLACEMENT.

This task covers: a. Removal b. Installation

INITIAL SETUP**Materials/Parts:**

Lock Washer
1, Appendix G
Marker tags (4)
7, Appendix E

Equipment Conditions:

Refrigeration system discharged (para 5-8).
Right side condenser door open.

a. Removal.

- (1) Loosen screw (1) and remove cover (2).
- (2) Tag wire leads (3). Remove two screws (4) and pull leads out of differential oil pressure switch (5).
- (3) Remove bolt (6), lock washer (7), and clamp (8). Discard lock washer.
- (4) Tag each capillary tube (9) and loosen two flare nuts (10) from tees (11).
- (5) Remove two bolts (12) and differential oil pressure switch (5).

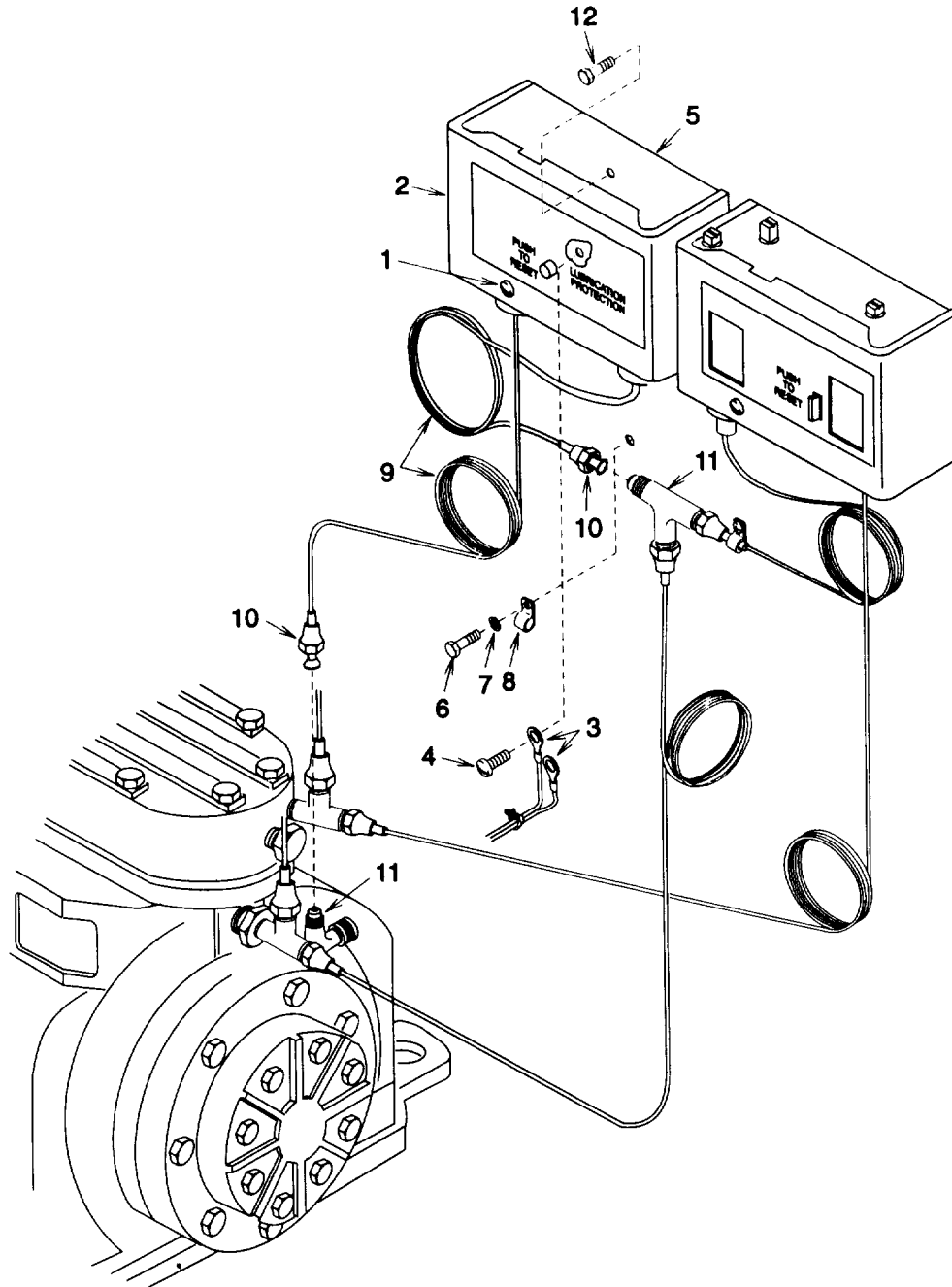


Figure 5-32. Differential Oil Pressure Switch.

5-36. DIFFERENTIAL OIL PRESSURE SWITCH S5 REPLACEMENT . - Continued**b. Installation.**

- (1) Loosen screw (1) and remove cover (2) from new differential oil pressure switch (5).
- (2) Remove and discard metal jumper from between terminals M and 2.
- (3) Install differential oil pressure switch (5) and two bolts (11).
- (4) Using tags on old differential pressure switch (5) for reference, neatly route capillary tubing (9) to tees (11) and carefully coil excess tubing as necessary.
- (5) Aline each capillary tube (9) to tee (11) and tighten two flare nuts (10).
- (6) Install clamp (8) around capillary tube (9). Install new lock washer (7) and bolt (6).
- (7) Push two wire leads (3) into differential oil pressure switch (5) and using tags and wiring diagram (fig. 2-4), install wire leads and screws (4). Remove tags.
- (8) Install cover (2) and tighten screw (1).

NOTE**FOLLOW-ON MAINTENANCE:**

Close right side condenser door.

Replace dehydrator (para 5-15).

Leak check (para 5-11), evacuate (para 5-12), and charge (para 5-13) the refrigeration system.

5-37. DUAL PRESSURE CONTROL SWITCH S2 REPLACEMENT.

This task covers: **a. Removal** **b. Installation**

INITIAL SETUPMaterials/Parts:

Lock Washer
1, Appendix G
Marker tags (4)
7, Appendix E

Equipment Conditions:

Refrigeration system discharged (para 5-8).
Right side condenser door open.

a. Removal.

- (1) Loosen screw (1) and remove cover (2).
- (2) Tag wire leads (3). Remove two screws (4) and pull leads out of dual pressure control switch (5).
- (3) Remove bolt (6), lock washer (7), and clamp (8). Discard lock washer.
- (4) Tag each capillary tube (9) and loosen two flare nuts (10) from tees (11).
- (5) Remove two bolts (12) and dual pressure control switch (5).

5-37. DUAL PRESSURE CONTROL SWITCH S2 REPLACEMENT . - Continued

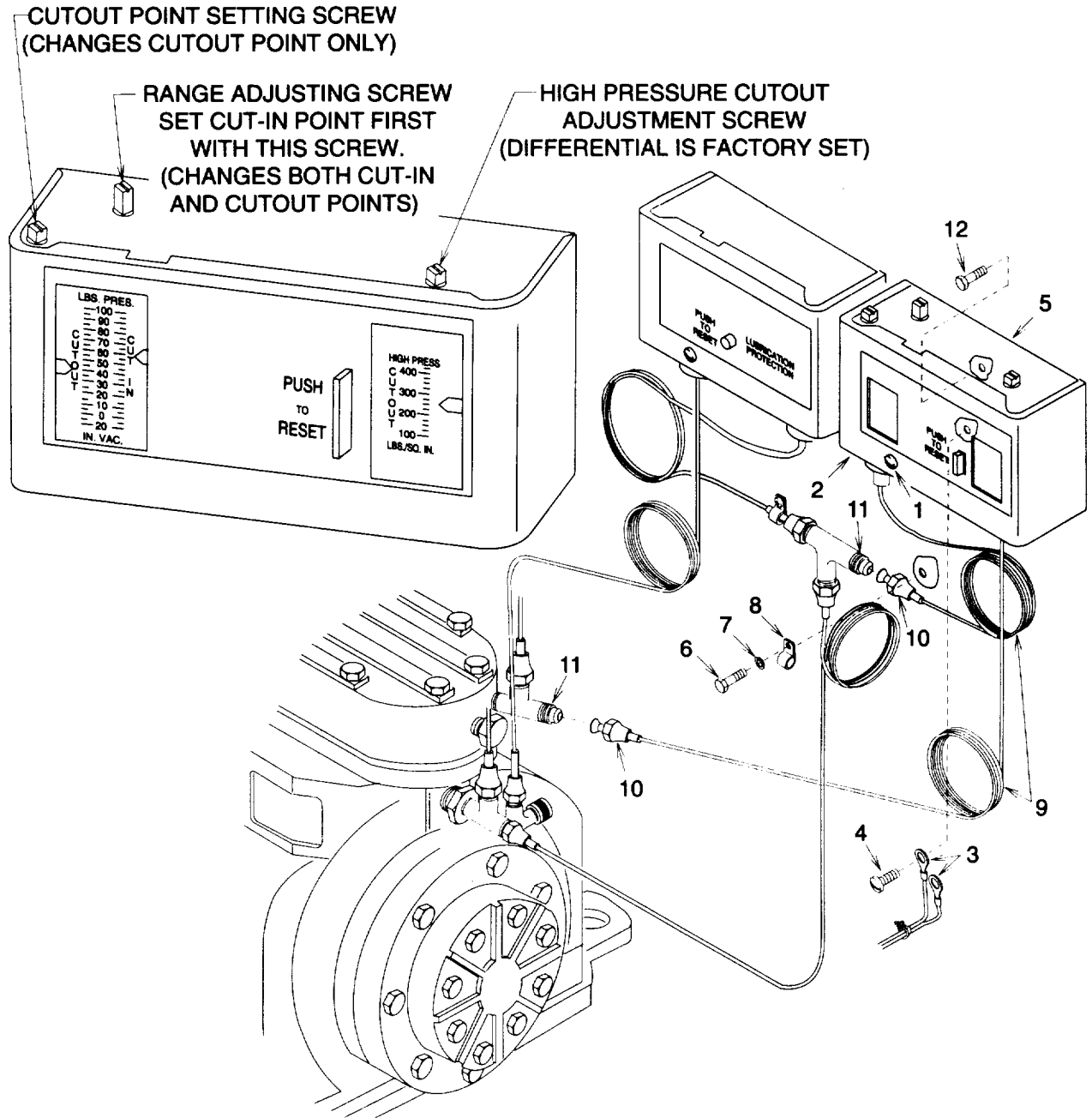


Figure 5-33. Dual Pressure Control Switch.

b. Installation.

- (1) Loosen screw (1) and remove cover (2) from new dual pressure control switch (5).
- (2) Install dual pressure control switch (5) and two bolts (12).
- (3) Using tags on old dual pressure control switch (5) for reference, neatly route new capillary tubing (9) to tees (11) and carefully coil excess tubing as necessary.
- (4) Aline each capillary tube (9) to tee (11) and tighten two flare nuts (10).
- (5) Install clamp (8) around capillary tube (9). Install new lock washer (7) and bolt (6).
- (6) Push two wire leads (3) into dual pressure control switch (5) and using tags and wiring diagram (fig. 2-4), install wire leads and screws (4). Remove tags.
- (7) Install cover (2) and tighten screw (1).
- (8) Adjust HIGH PRESSure CUTOFF to 305, low pressure CUT IN to 0, and low pressure CUTOFF to 15 IN. VAC.

NOTE**FOLLOW-ON MAINTENANCE:**

Close right side condenser door.

Replace dehydrator (para 5-15).

Leak check (para 5-11), evacuate (para 5-12), and charge (para 5-13) the refrigeration system.

5-38. COMPRESSOR B1 TESTING. REPAIR, AND REPLACEMENT.

This task covers: a. INSERT FUNCTION b. INSERT FUNCTION c. INSERT FUNCTION

INITIAL SETUPMaterials/Parts:

Locknut (4)
 19, Appendix G
 Service Valve Gasket (Suction)
 20, Appendix G
 Service Valve Gasket (Discharge)
 21, Appendix G
 Cylinder Head Gasket
 22, Appendix G
 Valve Plate Gasket
 23, Appendix G
 Sight Glass
 24, Appendix G
 Fused Cluster Terminal
 26, Appendix G
 is Fused Cluster Seal
 in 27, Appendix G
 does Terminal Mounting Plate Gasket
 28, Appendix G
 Oil Pump Gasket
 18, Appendix G

Materials/Parts:

Seal
 2, Appendix G
 Marker tags (15)
 7, Appendix E
 Anti-Seize Tape
 22, Appendix E
 Compressor Lubricating Oil
 21, Appendix E

General Safety Instructions:**WARNING**

Compressor lubricating oil used in this refrigeration system caustic. Wear gloves and a face protector or safety glasses any situation where skin or eye contact is possible. If oil contact skin, wash with soap and water.

Equipment Conditions:

Refrigeration system discharged (para 5-8).
 Front bottom doors open.
 Side condenser doors open.

a. Testing. (See Figure 1-4.)

- (1) Remove two screws (1) and cover (2).
- (2) Using multimeter set to measure continuity, check compressor (3) winding continuity between terminals 1 to 2, 1 to 3, and 3 to 2. Continuity should be indicated. If continuity was not indicated, replace compressor.
- (3) Using multimeter set to measure continuity, check compressor (3) winding continuity between each terminal 1, 2, and 3 to compressor frame ground. No continuity should be indicated. If continuity was indicated, replace compressor.
- (4) Remove eight screws (4), cylinder head (5), cylinder head gasket (6), valve plate assembly (7), two reed valves (8), and valve plate gasket (9). Discard gaskets.
- (5) Examine reed valves (8) for warpage and any other physical damage. Replace valve plate assembly (7) if reed valves are damaged.

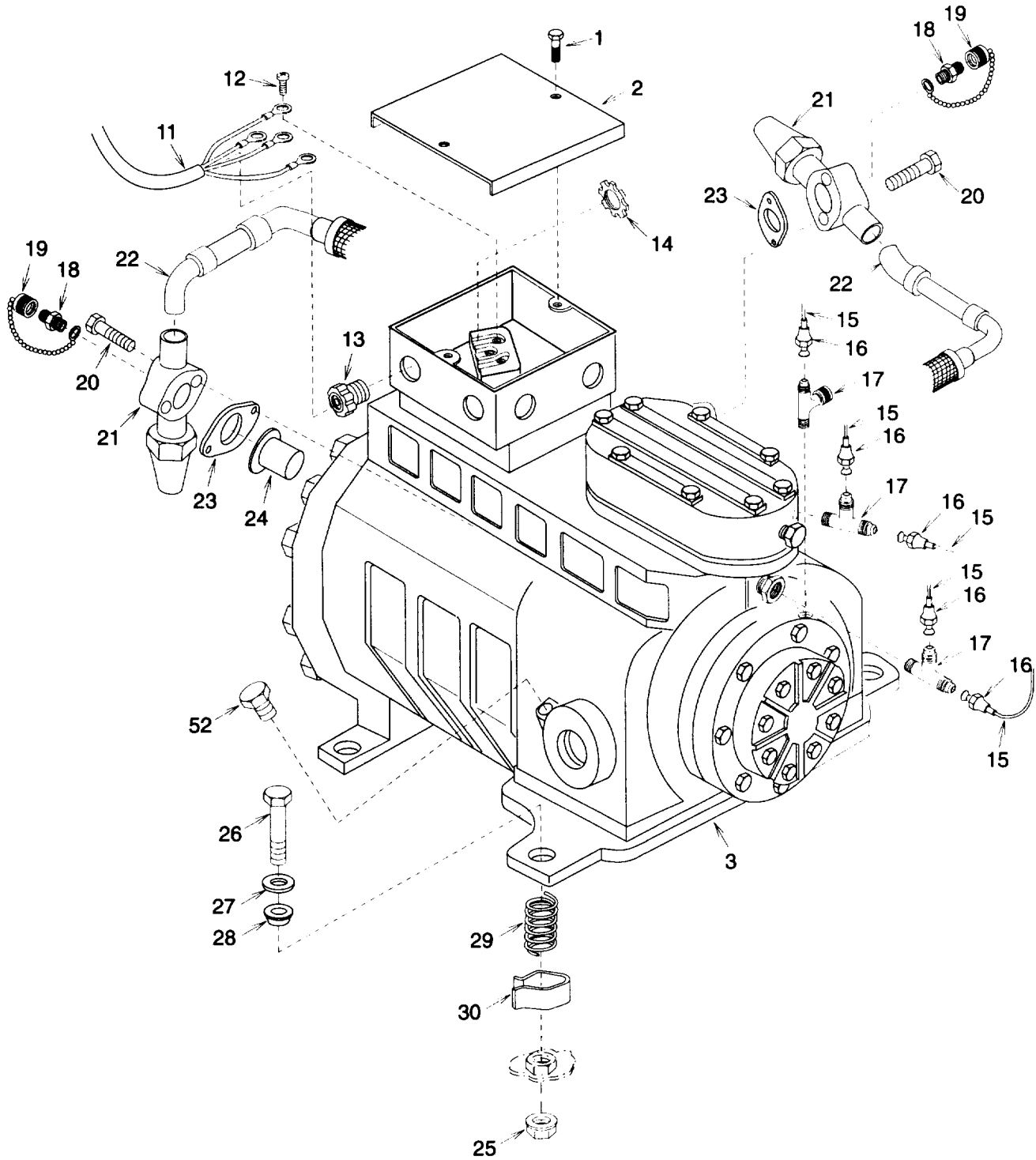


Figure 5-34. Compressor (Sheet 1 of 2).

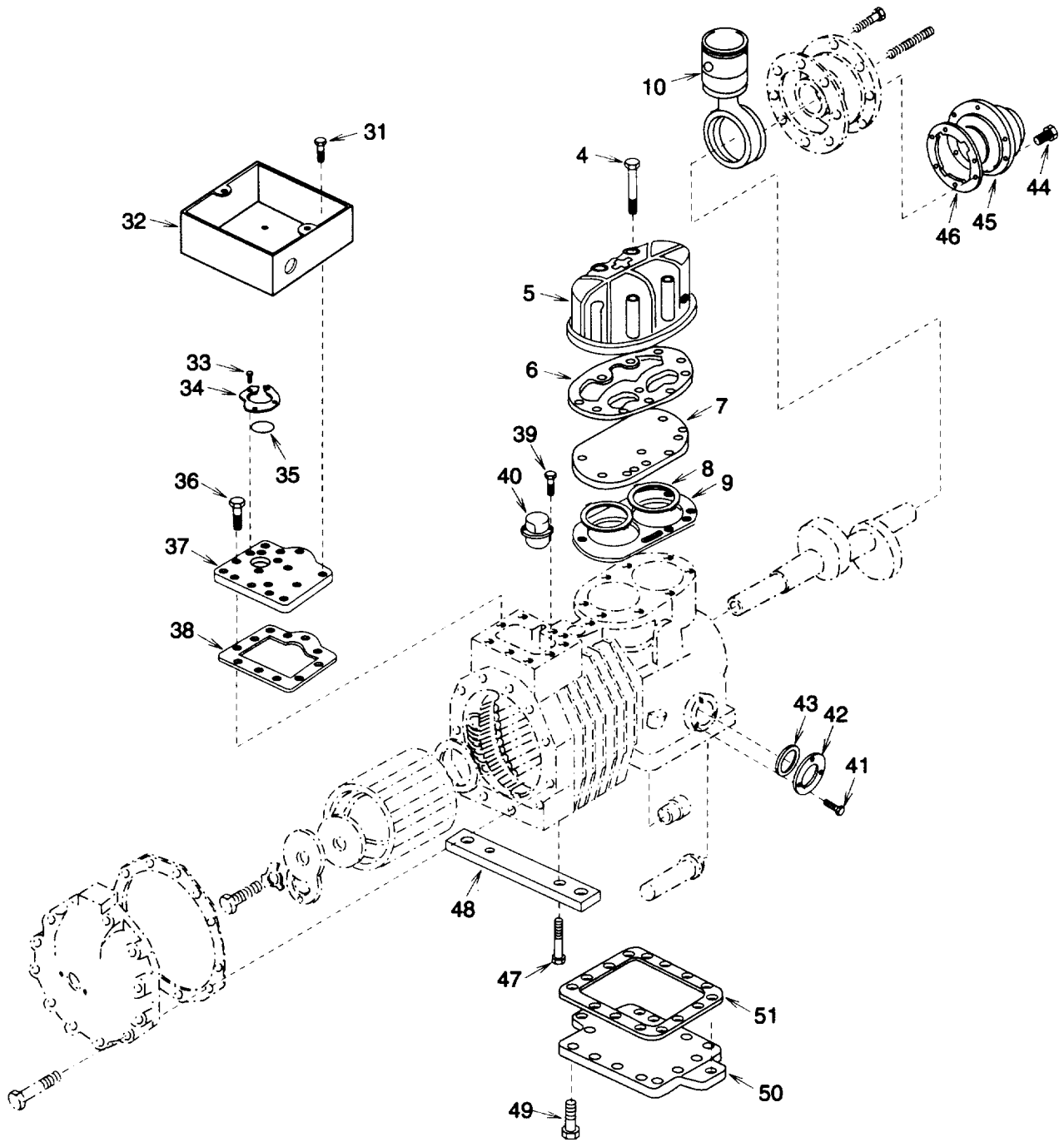


Figure 5-34. Compressor (Sheet 2 of 2).

- (6) Examine compressor (3) cylinder walls for any scoring or excessive wear (groove at top of piston (10) travel). Replace compressor if scored or excessively worn.
- (7) Press on top of highest piston (10). When pushed down, the higher piston should have some resistance and the lower piston should rise. Repeat for other piston. If either piston was loose and did not cause the other one to rise, replace piston and any other damaged components.
- (8) If no failure was indicated, remove any gasket material from all machined gasket surfaces and install new valve plate gasket (9), two reed valves (8), valve plate assembly (7), new cylinder head gasket (6), cylinder head (5), and eight screws (4).
- (9) Install cover (2) and two screws (1).

b. Removal.

NOTE

Remove only items necessary to access defective component(s).

- (1) Remove center post (para 4-15) from between front bottom doors.
- (2) Remove two screws (1) and cover (2).
- (3) Tag wire leads (11). Remove four screws (12) and pull wire leads out through strain relief cable bushing (13).
- (4) Remove conduit locknut (14) and strain relief cable bushing (13).
- (5) Tag capillary tubes (15) and loosen five flare nuts (16) from tees (17) and carefully pull tubes away from tees being careful not to bend or kink tubes.
- (6) Remove three tees (17).
- (7) Remove two couplings (18) and caps and chains (19).
- (8) Remove four screws (20). Pull two service valves (21) away from compressor (3) being careful not to bend or kink tubing (22). Remove two service valve gaskets (23) and suction screen (24). Discard gaskets.
- (9) Remove four locknuts (25), screws (26), flat washers (27), and mounting spacers (28). Discard locknuts.
- (10) Carefully lift each corner of compressor (3) and remove one each mounting spring (29) and shipping bracket (30).

5-38. COMPRESSOR B1 TESTING, REPAIR, AND REPLACEMENT. - Continued**WARNING**

Compressor weight exceeds 290 lb (132 kg). Use appropriate lifting device to avoid personal injury.

- (11) Remove compressor (3).
- (12) De-braze two service valves (21) from tubing (22) (para 5-10).

c. Disassembly.**NOTE**

Disassemble only as necessary to replace defective component(s).

- (1) Remove eight screws (4), cylinder head (5), cylinder head gasket (6), valve plate assembly (7), two reed valves (8), and valve plate gasket (9). Discard gaskets.
- (2) Remove four screws (31) and terminal box (32).
- (3) Remove three screws (33), fused cluster terminal (34), and fused cluster seal (35). Discard fused cluster terminal and seal.
- (4) Remove 10 screws (36), terminal plate (37), and terminal mounting plate gasket (38). Discard gasket.
- (5) Remove two screws (39) and protector (40).
- (6) Remove three screws (41), sight glass (42), and seal (43). Discard seal.
- (7) Remove six screws (44), oil pump (45), and oil pump gasket (46). Discard gasket.
- (8) Remove two screws (47) and mounting foot plate (48).
- (9) Remove 27 screws (49), bottom plate (50), and bottom plate gasket (51). Discard gasket.

d. Assembly.

- (1) Remove any gasket material from all machined gasket surfaces.
- (2) Install new bottom plate gasket (51), bottom plate (50), and 27 screws (49).
- (3) Install mounting foot plate (48) and two screws (47).
- (4) Install new oil pump gasket (46), oil pump (45), and six screws (44).
- (5) Install new seal (43), sight glass (42) and three screws (41).
- (6) Install protector (40) and two screws (39).
- (7) Install new terminal mounting plate gasket (38), terminal plate (37), and 10 screws (36).

- (8) Install new fused cluster seal (35), new fused cluster terminal (34), and three screws (33).
- (9) Install terminal box (32) and four screws (31).
- (10) Install new valve plate gasket (9), two reed valves (8), valve plate assembly (7), new cylinder head gasket (6), cylinder head (5), and eight screws (4).
- (11) Check compressor lubricating oil level at sight glass (42). Level should be at mid-point of sight glass. Add or remove oil as necessary.
 - (a) Remove plug (52).
 - (b) Add or remove oil as necessary.
 - (c) Wrap anti-seize tape around plug (52) threads.
 - (d) Install plug (52).

e. Installation.

- (1) Install two service valves (21) onto tubing (22) with mounting surfaces at right angles to each other and braze connection (para 5-10).

WARNING

Compressor weight exceeds 400 lb (181 kg). Use appropriate lifting device to avoid personal injury.

- (2) Install compressor (3).
- (3) Carefully lift each corner of compressor (3) and install one each mounting spring (29) and shipping bracket (30).
- (4) Install four mounting spacers (28), flat washers (27), screws (26), and new locknuts (25).
- (5) Install suction screen (24), two new service valve gaskets (23), service valves (21), and four screws (20).
- (6) Wrap anti-seize tape around threaded end of coupling (18). Install one cap and chain (19) onto each coupling and install two couplings.
- (7) Wrap anti-seize tape around threaded end of each tee (17) and install three tees.
- (8) Align capillary tubes (15) with tees (17) using tags as reference being careful not to bend or kink tubes. Tighten five flare nuts (16).
- (9) Install strain relief cable bushing (13) and conduit locknut (14).
- (10) Push wire leads (11) through strain relief cable bushing (13). Install wire leads, using tags and wiring diagram (fig. 1-4), and four screws (12). Remove tags.

5-38. COMPRESSOR B1 TESTING, REPAIR, AND REPLACEMENT. - Continued

- (11) Install cover (2) and two screws (1).
- (12) Install center post (para 4-15) between front bottom doors.

NOTE**FOLLOW-ON MAINTENANCE****Close side condenser doors.****Close front bottom doors.****Replace dehydrator (para 5-15).****Leak check (para 5-11), evacuate (para 5-12), and charge (para 5-13) the refrigeration system.****5-39. CONDENSER FRAME RFPAIR.****This task covers: a. Repair****INITIAL SETUP****Tools:**

Drill Motor
1, Section III, Appendix B
Drill Bit Set
1, Section III, Appendix B
Rivet Gun
1, Section III, Appendix B

Equipment Condition:

Refrigeration unit shut down (para 2-7) and power disconnected.

General Safety Instruction.:**WARNING**

High voltage and rotating parts are used in the refrigeration unit. Personal injury can result if power is connected.

Materials/Parts:

Lock Washer (2)
1, Appendix G
Self Locking Nuts (12)
17, Appendix G
Self Locking Nut
12, Appendix G
Self Locking Nuts (34)
25, Appendix G
Silicone RTV
20, Appendix E

Repair.**NOTE**

Repair to condenser frame at this maintenance level is limited to replacement of any damaged rivets or blind rivet nuts and replacement of evaporator housing and heat shield.

- (1) Drill through rivet or blind rivet nut using drill bit slightly smaller than rivet diameter.

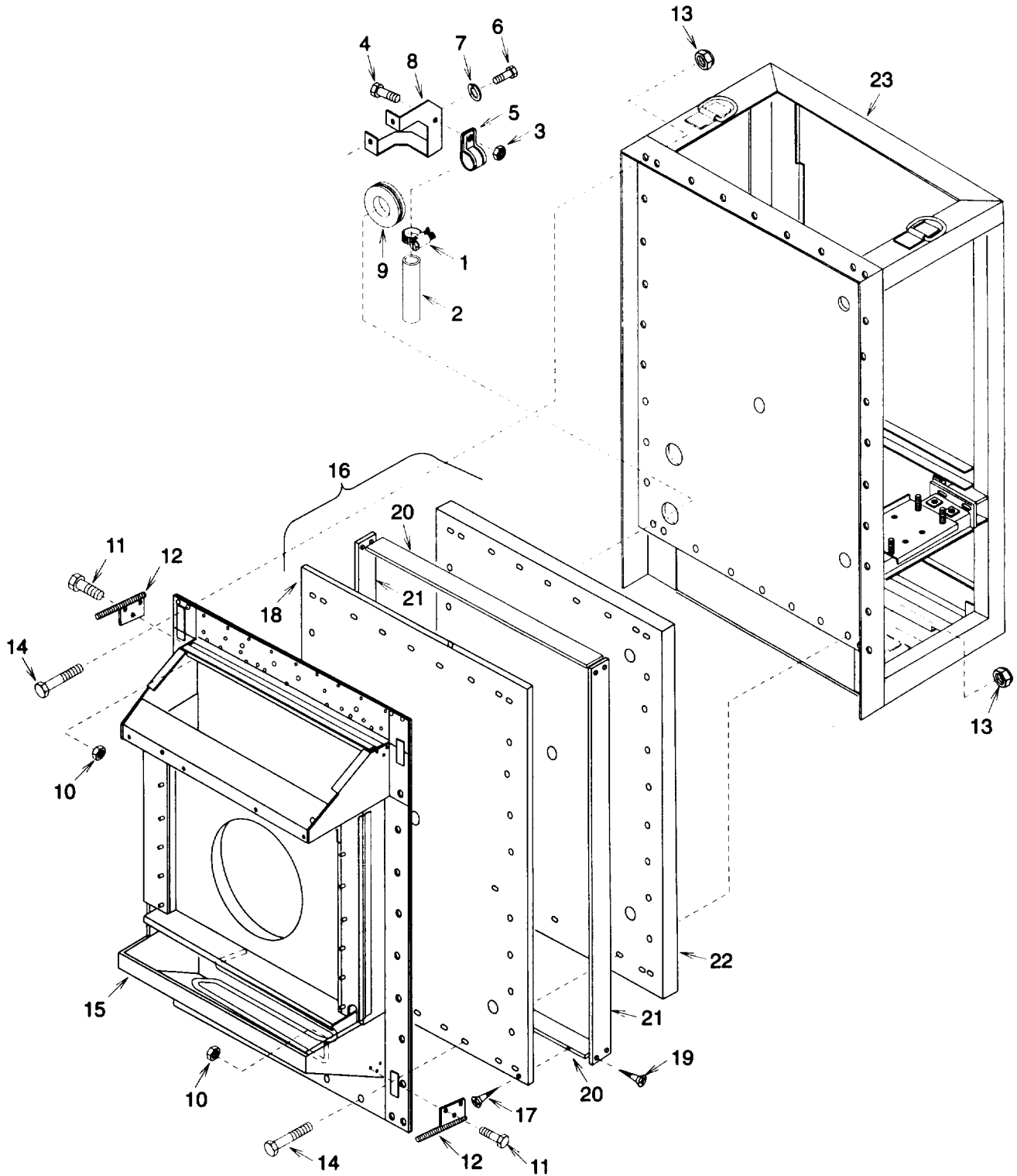


Figure 5-35. Condenser Frame.

5-38. CONDENSER FRAME REPAIR. - Continued

- (2) Remove any remaining rivet material.
- (3) Install new rivet or blind rivet nut as required.
- (4) Defrost Tube And Bracket Assembly Removal.

NOTE

Remove only items necessary to replace damaged component(s).

- (a) Remove hose clamp (1) and plastic tubing (2).
 - (b) Remove self locking nut (3), bolt (4), and clamp (5). Discard self locking nut.
 - (c) Remove two bolts (6), lock washers (7), and defrost tube bracket (8). Discard lock washers.
 - (d) Remove grommet (9).
 - (e) Remove any silicone RTV remaining in grommet (9).
- (5) Evaporator Housing And Heat Shield Removal.

NOTE

Remove only items necessary to replace damaged component(s).

- (a) Remove gasket (heat shield) (para 4-44).
- (b) Remove heat exchanger (para 5-33).
- (c) Remove expansion valve (para 5-34).
- (d) Remove evaporator coil (para 5-35).
- (e) Remove evaporator housing tubing and fittings (para 5-32).
- (f) Remove 12 self locking nuts (10), bolts (11), and four unit mounts (12). Discard self locking nuts.

NOTE

Heat shield assembly will be loose when evaporator housing is removed.

- (g) Remove 34 self locking nuts (13), bolts (14), evaporator housing (15), and heat shield assembly (16). Discard self locking nuts.
- (h) Remove 34 screws (17) and heat shield panel (18).
- (i) Remove eight screws (19), four heat shield beams (20) and (21), and heat shield insulation (22).

(6) Evaporator Housing And Heat Shield Installation.

- (a) Install heat shield beams (20) and (21) around heat shield insulation (22) and install eight screws (19).
- (b) Install heat shield panel (18) and 34 screws (17).
- (c) Align heat shield assembly (16) and evaporator housing (15) onto condenser frame (23) then install 34 bolts (14) and new self locking nuts (13).
- (d) Install four unit mounts (12), 12 bolts (11), and new self locking nuts (10).
- (e) Install evaporator housing tubing and fittings (para 5-32).
- (f) Install evaporator coil (para 5-35).
- (g) Install expansion valve (para 5-34).
- (h) Install heat exchanger (para 5-33).
- (i) Install gasket (heat shield) (para 4-44).
- (j) Install refrigeration unit onto refrigerator enclosure (para 4-6).

(7) Defrost Tube And Bracket Assembly Installation.

- (a) Install grommet (9).
- (b) Install defrost tube bracket (8), two new lock washers (7), and bolts (6).
- (c) Install clamp (5), bolt (4), and new self locking nut (3).
- (d) Install plastic tubing (2) and hose clamp (1).
- (e) Apply silicone RTV into grommet (9) to seal evaporator enclosure.

CHAPTER 6

GENERAL SUPPORT MAINTENANCE INSTRUCTIONS

6-1. GENERAL.

The only item authorized by the Maintenance Allocation Chart (MAC) to the general support maintenance level is welding repair to the condenser frame. However, general support maintenance may be called upon to perform any or all of the MAC items listed for unit and direct support maintenance for rehabilitation or overhaul of the refrigeration unit.

6-2. CONDENSER FRAME REPAIR.

This task covers: a. Repair

INITIAL SETUP**Tools:**

Torch Set
1, Section III, Appendix B

Equipment Conditions:

Refrigeration unit shut down (para 2-7) and power disconnected.

General Safety Instructions:**WARNING**

High voltage and rotating parts are used in the refrigeration unit. Personal injury can result if power is connected.

Repair.

- (1) Disassemble refrigeration unit as necessary and make repairs as indicated.
- (2) Repair any minor sheet metal dents and bent edges by straightening using common sheet metal repair procedures.
- (3) Weld any cracks or breaks in frame members or welds per MIL-B-7883.
- (4) Touch-up any painted surfaces per TM 43-0139.
- (5) Assemble refrigeration unit as necessary to return to service.

APPENDIX A

REFERENCES

A-1. SCOPE.

This appendix list all forms, field manuals, and technical manuals referenced in this manual.

A-2. FORMS.

Recommended Changes to Publications.....DA Form 2028

Recommended Changes to Equipment Technical Manuals DA Form 2028-2

Product Quality Deficiency Report Standard Form 368

Log Book DA Form 2408-9

Equipment Inspection and Maintenance Worksheet.....DA Form 2404

A-3. FIELD MANUALS.

NBC Contamination Avoidance..... FM 3-3

NBC Protection..... FM 3-4

NBC Decontamination FM 3-5

A-4. TECHNICAL MANUALS.

Destruction of Army Material to Prevent Enemy Use TM 750-244-3

Unit, Direct Support, and General Support Maintenance
Repair Parts and Special Tools List TM 9-4110-256-24P

A-5. MISCELLANEOUS PUBLICATIONS.

Army Logistics Readiness and SustainabilityAR 700-138

Army Maintenance Management System (TAMMS).....DA Pam 738-750

Expendable Items
(Except Medical Class V, Repair Parts and Heraldic Items)CTA 50-970

Army Medical Department Expendable/Durable Items CTA 8-100

Methods of Preservation MIL-P-116

Crates, Wood, Open And Covered..... MIL-C-52950

A-6. WARRANTY TECHNICAL BULLETIN.

Refrigeration Unit, Mechanical, Panel Mounted for Refrigerator,
Prefabricated, Panel Type, Electric motor Driven,
10, 000 BTU Model F10000RE TB 9-4110-256-24

APPENDIX B

MAINTENANCE ALLOCATION CHART (MAC)

SECTION I. INTRODUCTION

B-1. The Army Maintenance System MAC

This introduction provides a general explanation of all maintenance and repair functions authorized at the two maintenance levels under the Two-Level Maintenance System concept.

The MAC (immediately following the introduction) designates overall authority and responsibility for the performance of maintenance functions on the identified end item or component. The application of the maintenance functions to the end item or component shall be consistent with the capacities and capabilities of the designated maintenance levels, which are shown on the MAC in column (4) as:

Field - includes two columns, Unit maintenance and Direct Support maintenance. The Unit maintenance column is divided again into two more subcolumns, C for Operator or Crew and O for Unit maintenance.

Sustainment – includes two subcolumns, General Support (H) and Depot (D)

The tools and test equipment requirements (immediately following the MAC) list the tools and test equipment (both special tools and common tool sets) required for each maintenance function as referenced from the MAC.

The remarks (immediately following the tools and test equipment requirements) contain supplemental instructions and explanatory notes for a particular maintenance function.

B-2. Maintenance Functions

Maintenance functions are limited to and defined as follows:

1. Inspect. To determine the serviceability of an item by comparing its physical, mechanical, and/or electrical characteristics with established standards through examination (e.g., by sight, sound, or feel.) This includes scheduled inspection and gagings and evaluation of cannon tubes.
2. Test. To verify serviceability by measuring the mechanical, pneumatic, hydraulic, or electrical characteristics of an item and comparing those characteristics with prescribed standards on a scheduled basis, i.e., load testing of lift devices and hydrostatic testing of pressure hoses.
3. Service. Operations required periodically to keep an item in proper operating condition, e.g. to clean (includes decontaminate, when required), to preserve, to drain, to paint, or to replenish fuel, lubricants, chemical fluids, or gases. This includes scheduled exercising and purging of recoil mechanisms. The following are examples of service functions:
 - a. Unpack. To remove from packing box for service or when required for the performance of maintenance operations.
 - b. Repack. To return item to packing box after service and other maintenance operations.
 - c. Clean. To rid the item of contamination.

B-2. Maintenance Functions-Continued

- d. Touch up. To spot paint scratched or blistered surfaces.
 - e. Mark. To restore obliterated identification.
4. Adjust. To maintain or regulate, within prescribed limits, by bringing into proper or position, or by setting the operating characteristics to specified parameters.
 5. Align. To adjust specified variable elements of an item to bring about optimum or desired performance
 6. Calibrate. To determine and cause corrections to be made or to be adjusted on instruments of test, measuring, and diagnostic equipment used in precision measurement. Consists of comparisons of two instruments, one of which is a certified standard of known accuracy, to detect and adjust any discrepancy in the accuracy of the instrument being compared.
 7. Remove/install. To remove and install the same item when required to perform service or other maintenance functions. Install may be the act of emplacing, seating, or fixing into position a spare, repair part, or module (component or assembly) in a manner to allow the proper functioning of an equipment or system.
 8. Paint. To prepare and spray color coats of paint so that the ammunition can be identified and protected. The color indicating primary use is applied, preferably, to the entire exterior surface as the background color of the item. Other markings are to be repainted as original so as to retain proper ammunition identification.
 9. Replace. To remove an unserviceable item and install a serviceable counterpart in its place. "Replace" is authorized by the MAC and assigned maintenance level is shown as the third position code of the Source, Maintenance and Recoverability (SMR) code.
 10. Repair. The application of maintenance services, including fault location/troubleshooting, removal/installation, disassembly/assembly procedures and maintenance actions to identify troubles and restore serviceability to an item by correcting specific damage, fault, malfunction, or failure in a part, subassembly, module (component or assembly), end item, or system.

NOTE

The following definitions are applicable to the "repair" maintenance function:

Services. Inspect, test, service, adjust, align, calibrate, and/or replace.

Fault location/troubleshooting. The process of investigating and detecting the cause of equipment malfunctioning; the act of isolating a fault within a system or Unit Under Test (UUT).

Disassembly/assembly. The step by step breakdown (taking apart) of a spare/functional group coded item to the level of its least component, that is assigned an SMR code for the level of maintenance under consideration (i.e. identified as maintenance significant).

Actions. Welding, grinding, riveting, straightening, facing, machining, and/or resurfacing.

B-2. Maintenance Functions-Continued

11. Overhaul. That maintenance effort (service/action) prescribed to restore an item to a completely serviceable/operational condition as required by maintenance standards in appropriate technical publications. Overhaul is normally the highest degree of maintenance performed by the Army. Overhaul does not normally return an item to like new condition.
12. Rebuild. Consists of those services/actions necessary for the restoration of unserviceable equipment to a like new condition in accordance with original manufacturing standards. Rebuild is the highest degree of material maintenance applied to Army equipment. The rebuild operation includes the act of returning to zero those age measurements (e.g., hours/miles) considered in classifying Army equipment/components.

B-3. Explanation of Columns in the MAC, Section II.

Column (1) Group Number. Column (1) lists Functional Group Code (FGC) numbers, the purpose of which is to identify maintenance significant components, assemblies, subassemblies, and modules with the Next Higher Assembly (NHA).

Column (2) Component/Assembly. Column (2) contains the item names of components, assemblies, subassemblies, and modules for which maintenance is authorized.

Column (3) Maintenance Function. Column (3) lists the functions to be performed on the item listed in column (2). (For a detailed explanation of these functions refer to "Maintenance Functions" outlined above).

Column (4) Maintenance Level. Column (4) specifies each level of maintenance authorized to perform each function listed in column (3), by indicating work time required (expressed as manhours in whole hours or decimals) in the appropriate subcolumn. This work time figure represents the active time required to perform that maintenance function at the indicated level of maintenance. If the number or complexity of the tasks within the listed maintenance function varies at different maintenance levels, appropriate work time figures are to be shown for each level. The work time figure represents the average time required to restore an item (assembly, subassembly, component, module, end item, or system) to a serviceable condition under typical field operating conditions. This time includes preparation time (including any necessary disassembly/assembly time), troubleshooting/fault location time, and quality assurance time in addition to the time required to perform the specific tasks identified for the maintenance functions authorized in the MAC. The symbol designations for the various maintenance levels are as follows:

Field:

- C Operator or Crew maintenance
- O Unit maintenance
- F Direct Support maintenance

Sustainment:

- L Specialized Repair Activity
- H General Support maintenance
- D Depot maintenance

B-3. Explanation of Columns in the MAC, Section II - Continued.**NOTE**

The "L" maintenance level is not included in column (4) of the MAC. Functions to this level of maintenance are identified by work time figure in the "H" column of column (4), and an associated reference code is used in the REMARKS column (6). This code is keyed to the remarks and the SRA complete repair application is explained there.

Column (5) Tools and Equipment Reference Code. Column (5) specifies, by code, those common tool sets (not individual tools), common Test, Measurement and Diagnostic Equipment (TMDE), and special tools, special TMDE, and support special equipment required to perform the designated function. Codes are keyed to the entries in the tools and test equipment table.

Column (6) Remarks Code. When applicable, this column contains a letter code, in alphabetic order, which is keyed to the remarks table entries.

B-4. Explanation of Columns in the Tools and Test Equipment Requirements, Section III.

Column (1) – Tool or Test Equipment Reference Code. The tool or test equipment reference code correlates with a code used in column (5) of the MAC.

Column (2) – Maintenance Level. The lowest level of maintenance authorized to use the tool or test equipment.

Column (3) – Nomenclature. Name or identification of the tool or test equipment.

Column (4) – National Stock Number (NSN). The NSN of the tool or test equipment.

Column (5) – Tool Number. The manufacturer's part number.

B-5. Explanation of Columns in Remarks, Section IV.

Column (1) – Remarks Code. The code recorded in column (6) of the MAC.

Column (2) – Remarks. This column lists information pertinent to the maintenance function being performed as indicated in the MAC.

**Section II. MAINTENANCE ALLOCATION CHART (MAC)
FOR
REFRIGERATION UNIT**

(1) GROUP NUMBER	(2) COMPONENT/ ASSEMBLY	(3) MAINTENANCE FUNCTION	(4) MAINTENANCE LEVEL					(5) TOOLS AND EQUIPMENT REFERENCE CODE	(6) REMARKS CODE	
			FIELD		SUSTAINMENT					
			UNIT		DIRECT SUPPORT	GENERAL SUPPORT	DEPOT			
			C	O	F	H	D			
00	REFRIGERATION UNIT									
01	CABINET, PANELS, DOORS, & SCREENS	PANEL	Inspect	0.1	0.5	1.0		1		
			Repair						1	
			Replace							
		DOORS	Inspect	0.1	0.5	1.0		1		
			Service						1	
			Replace							
	GUARDS	Inspect	0.1	0.5	1.0		1			
		Repair						1		
		Replace								
	BOLT, BARREL	Inspect	0.1	0.5			1			
		Service						1		
		Replace								
02	ELECTRICAL AND CONTROL SYSTEM	WIRES, CABLES & HARNESES	Inspect	0.1	0.5			1,4		
			Test						1,4	
			Repair							
			Replace							
		CIRCUIT BREAKER	Inspect	0.1	0.5			1		
			Replace							
	INDICATOR (LIGHT)	Inspect	0.1	0.5			1			
		Test						1		
		Repair								
		Replace								

**MAINTENANCE ALLOCATION CHART (MAC)
FOR
REFRIGERATION UNIT – Continued**

(1) GROUP NUMBER	(2) COMPONENT/ ASSEMBLY	(3) MAINTENANCE FUNCTION	(4) MAINTENANCE LEVEL					(5) TOOLS AND EQUIPMENT REFERENCE CODE	(6) REMARKS CODE	
			FIELD		SUSTAINMENT					
			UNIT		DIRECT SUPPORT	GENERAL SUPPORT	DEPOT			
			C	O	F	H	D			
02 -Cont	FUSE	Inspect		0.1						
		Test		0.5				1		
		Replace		0.2				1		
	MOTOR STARTER	Inspect		0.1						
		Test		0.5				1		
		Repair		0.5				1		
		Replace		1.0				1		
	CONTRACTOR	Inspect		0.1						
		Test		0.5				1		
		Replace		1.0				1		
	RELAY CONTROL	Inspect		0.1						
		Test		0.5				1		
		Replace		1.0				1		
	HOURMETER	Inspect	0.1							
		Test		0.5				1		
		Replace		1.0				1		
	SWITCH, TOGGLE	Inspect	0.1							
		Test		0.5				1		
		Replace		1.0				1		
	TIMER, REPEAT CYCLE (DEFROST)	Inspect		0.1						
		Test		0.5				1		
		Replace		1.0				1		
	THERMOSTAT REMOTE BULB (TEMPERATURE CONTROL)	Inspect		0.1						
		Test		0.5				1		
Replace			1.0				1			

**MAINTENANCE ALLOCATION CHART (MAC)
FOR
REFRIGERATION UNIT – Continued**

(1) GROUP NUMBER	(2) COMPONENT/ ASSEMBLY	(3) MAINTENANCE FUNCTION	(4) MAINTENANCE LEVEL					(5) TOOLS AND EQUIPMENT REFERENCE CODE	(6) REMARKS CODE	
			FIELD		SUSTAINMENT					
			UNIT		DIRECT SUPPORT	GENERAL SUPPORT	DEPOT			
			C	O	F	H	D			
02 - Cont	THERMOMETER (REFRIGERATION TEMPERATURE)	Inspect	0.1							
		Replace		0.5				1		
	SWITCH, DEFROST TEMPERATURE	Inspect		0.1					1	
		Test		0.5					1	
		Replace		1.0					1	
	BLOCK, POWER DISTRIBUTION	Inspect		0.1					1	
		Test		0.5					1	
		Replace		1.0					1	
	SWITCHES, PUSH (DOOR)	Inspect	0.1							
		Test		0.5					1	
		Replace		1.0					1	
	MOTOR, AC	Inspect		0.1						
Test			1.0					1		
Replace			1.0					1		
03	POWER TRANSMISSION/ AIR HANDLING	Inspect	0.1							
		Adjust		0.5					1	
	V BELT	Replace		0.5					1	
		Inspect	0.1	0.5						
	FANS	Replace		0.1					1	
		Inspect	0.1	0.5						
	BEARINGS. FLANGE	Service	0.1	0.2					1	
		Replace		2.0					1	
	PULLEYS	Inspect	0.1							
		Replace		0.1					1	
	SHAFT, FAN DRIVE	Inspect	0.1							
		Replace			4.0				1	

**MAINTENANCE ALLOCATION CHART (MAC)
FOR
REFRIGERATION UNIT – Continued**

(1) GROUP NUMBER	(2) COMPONENT/ ASSEMBLY	(3) MAINTENANCE FUNCTION	(4) MAINTENANCE LEVEL					(5) TOOLS AND EQUIPMENT REFERENCE CODE	(6) REMARKS CODE	
			FIELD		SUSTAINMENT					
			UNIT		DIRECT SUPPORT	GENERAL SUPPORT	DEPOT			
			C	O	F	H	D			
04	REFRIGERATION SYSTEM									
	DEHYDRATOR (FILTER DRIER)	Inspect Replace	0.1		3.0			1,2,6		
	GAGES	Inspect Replace	0.1		3.0			1,2,6		
	STRAINER	Inspect Replace	0.1		3.0			1,2,6		
	RECEIVER	Inspect Replace	0.1		3.0			1,2,6		
	CONDENSER COIL	Inspect Service Replace		0.1 1.0	4.0			3 1,2,5,6		
	PRESSURE REGULATOR VALVES	Inspect Replace	0.1		3.0			1,2,5,6		
	METAL HOSE ASSEMBLIES (VIBRATION ELIMINATORS)	Inspect Replace	0.1		3.0			1,2,5,6		
	STOP VALVES (SHUT OFF)	Inspect Replace	0.1		3.0			1,2,5,6		
	SIGHT INDICATOR (SIGHT GLASS)	Inspect Replace	0.1		3.0			1,2,6		
	SOLENOID VALVES	Inspect Test Repair Replace	0.1	0.3 1.0	3.0			1 1,2,6		
								A		

**MAINTENANCE ALLOCATION CHART (MAC)
FOR
REFRIGERATION UNIT – Continued**

(1) GROUP NUMBER	(2) COMPONENT/ ASSEMBLY	(3) MAINTENANCE FUNCTION	(4) MAINTENANCE LEVEL					(5) TOOLS AND EQUIPMENT REFERENCE CODE	(6) REMARKS CODE
			FIELD		SUSTAINMENT				
			UNIT		DIRECT SUPPORT	GENERAL SUPPORT	DEPOT		
			C	O	F	H	D		
04 - Cont	FLARE COUPLINGS (SERVICE VALVES)	Inspect Replace	0.1		3.0			1,2,6	
	ACCUMULATOR	Inspect Replace	0.1		3.0			1,2,5,6	
	TUBING AND FITTINGS	Inspect Test Repair Replace	0.1		1.0 1.0 3.0			1,2,5,6 1,2,5,6	
	HEAT EXCHANGER	Inspect Replace		0.1	3.0			1,2,5,6	
	EXPANSION VALVES	Inspect Replace		0.1	3.0			1,2,6	
	EVAPORATOR COIL	Inspect Service Replace		0.1 1.0	4.0			3 1,2,5,6	
	SWITCHES, PRESSURE	Inspect Replace	0.1		3.0			1,2,6	
	COMPRESSOR	Inspect Test Repair Replace	0.1		0.5 8.0 6.0			1,2,6 1,2,5,6 1,2,5,6	
05	HOUSING								
	GASKET (HEAT SHIELD)	Inspect Replace	0.1	1.0				1	
	CONDENSOR FRAME (HOUSING)	Inspect Repair	0.1		6.0	6.0		1	B

**Section III. TOOLS AND TEST EQUIPMENT
FOR
REFRIGERATION UNIT**

TOOL OR TEST EQUIPMENT REFERENCE CODE	MAINTENANCE LEVEL	NOMENCLATURE	NATIONAL STOCK NUMBER	TOOL NUMBER
		NOTE Standard tools and test equipment in the following kits are adequate to accomplish the maintenance functions.		
1	O	Shop Equipment (1), Automotive Vehicle	4910-00-754-0654	SC 4910-95-A74
2	O	Tool Kit, Service, Refrigeration Unit	5180-00-597-1474	SC 5180-90-CL-N18
3	O	Comb, Fin	5120-00-157-2180	
4	O	Heat Gun	3439-01-037-7268	
5	F	Nitrogen Regulator	6680-00-503-1327	
6	F	Reclaim System, Refrigerant	4130-01-359-4516	

**Section IV. REMARKS
FOR
REFRIGERATION UNIT**

REMARKS CODE	REMARKS
Note A	Replace coil only.
Note B	Weld condenser frame only at general support maintenance level. Other than those items listed above there are no supplemental instructions or explanatory remarks required for the maintenance functions listed in Section II. All functions are sufficiently defined in Section I. Active time listed for maintenance task functions are with the refrigeration unit in off-equipment position.

APPENDIX C**COMPONENTS OF END ITEM (COEI) AND BASIC ISSUE ITEMS LIST****SECTION I INTRODUCTION****C-1. SCOPE.**

This appendix list components of the end item and basic issue items for the refrigeration unit to help you inventory the items for safe and efficient operation of the equipment.

C-2. GENERAL.

The Components of End Item (COEI) and Basic issue Items (BII) Lists are divided into the following sections:

a. Section II. Components of End Item. This listing is for information purposes only, and is not authority to requisition replacements. These items are part of the refrigeration unit. As part of the end item, these items must be with the end item whenever it is issued or transferred between property accounts. Items of COEI are removed and separately packaged for transportation or furnished to help you find and identify the items.

b. Section III. Basic Issue Items. These essential items are required to place the refrigeration unit in operation, operate it, and to do emergency repairs. Although shipped separately packaged, BII must be with the refrigeration unit during operation and when it is transferred between property accounts. This list is your authority to request/requisition them for replacement based on authorization of the end item by the TOE/MTOE. Illustrations are furnished to help you find and identify the items.

c. Explanation of Columns.

(1) Column (1), Ilus Number, gives you the number of the item illustrated.

(2) Column (2), National Stock Number, identifies the stock number of the item to be used for requisitioning purposes.

(3) Column (3), Description and Usable On Code, identifies the Federal item name (in all capital letters) followed by a minimum description when needed. The last line below the description is the Commercial and Government Entity Code (CAGEC) (in parentheses) and the part number.

(4) Column (4), U/I (unit of issue), indicates how the item is issued for the National Stock Number shown in column two.

(5) Column (5), Qty Rqd, indicates the quantity required.

SECTION II COMPONENTS OF END ITEM

There are no loose or separate components supplied with this refrigeration unit.

SECTION III BASIC ISSUE ITEMS LIST

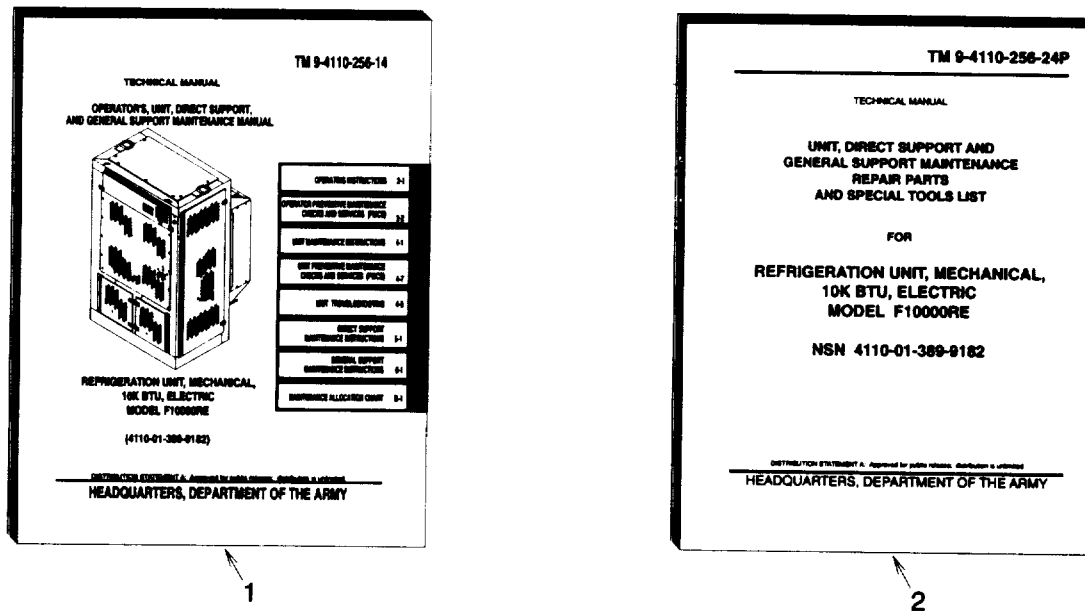


Figure C-1. Basic Issue Items

(1) Illus. No.	(2) National Stock Number	(3) Description (CAGEC) and Part Number	(4) U/M	(5) Qty Reqd
1		ARMY TECHNICAL MANUAL Operator's, Unit, Direct Support and General Support Maintenance for Refrigeration Unit, Mechanical 10K BTU Electric, Model F10000RE TM 9-4110-256-14	EA	1
2		ARMY TECHNICAL MANUAL Unit, Direct Support and General Support Maintenance Repair Parts and Special Tools List for Refrigeration Unit, Mechanical, 10K BTU, Electric Model F10000RE TM 9-4110-256-24P	EA	1

APPENDIX D

ADDITIONAL AUTHORIZATION LIST

There are no additional authorized items required for this refrigeration unit.

D-1/(D-2 blank)

APPENDIX E

EXPENDABLE AND DURABLE ITEMS LIST

SECTION I INTRODUCTION

E-1. SCOPE.

This appendix lists expendable and durable items you will need to maintain the refrigeration unit. This listing is for informational purposes only and is not authority to requisition the listed items. These items are authorized by CTA 50-970, expendable items (except Medical, Class V, Repair Parts, and Heraldic Items).

E-2. EXPLANATION OF COLUMNS.

- a. Column (1) - Item Number. This number is assigned to the entry in the listing for referencing when required.
- b. Column (2) - Level. This column identifies the lowest level of maintenance that requires the listed item.

C - Operator/Crew

O - Unit Maintenance

F - Direct Support Maintenance

H - General Support Maintenance

c. Column (3) - National Stock Number. This is the national stock number assigned to the item; use it to request or requisition the item.

d. Column (4) - Description. Indicates the federal item name and, if required a description to identify the item. The last line for each item indicates the Commercial and Government Entity Code (CAGEC) in parentheses followed by the part number.

e. Column (5) - Unit of Measure (U/M) Unit of Issue (U/I). This measure is expressed by a two character alphabetical abbreviation (e.g., EA, IN, PR). If the unit of measure differs from the unit of issue as shown in the Army Master Data File (AMDF) requisition the lowest unit of issue that will satisfy your requirements.

SECTION II EXPENDABLE AND DURABLE ITEMS LIST

(1) Item Number	(2) Level	(3) National Stock Number	(4) Description	(5) (U/M)/ (U/l)
1	O	7510-00-266-5006	Tape, Waterproof Packaging, PPP-T-60, Type IV	roll
2	O	8135-00-664-6958	Greaseproofed, Waterproof, Flexible Barrier Material, PP-C-843, Type II Class B	roll
3	O	7920-00-205-1711	Wiping Rag	bl
4	O	7930-00-985-6911	Detergent (81349) MIL-D-16791	gl
5	O	9150-01-178-4725	Lubricating Oil, General Purpose MIL-L-2104	qt
6	O	9150-00-985-7316	Grease, Multipurpose MIL-G-23549	lb
7	O	9905-00-537-8954	Marker Tag, MIL-T-12755	box
8	O	5935-00-725-4153	Solder, Lead-Tin, QQ-S-571 Type SN60WRP2	
9	F	3439-00-640-3713	Flux, Brazing O-F-499, type B	oz
10	O	5640-00-580-6276	Insulation Tape	roll
11	F	6830-00-292-0732	Nitrogen	cy
12	F		Refrigerant, R134a	
13	O	5350-00-192-5047	Abrasive Cloth	pg
14	O	3040-00-644-0439	Adhesive, General Purpose,	pt
15	F	Brazing Alloy, Silver	QQ-B-564, grade O, I or II	oz
16	F		Brazing Alloy, Silver QQ-B-564, grade III	oz
17	O	3439-01-045-7940	Flux, Solder, Liquid, Rosin Base MIL-F-14256	qt
18	F		Acetone	gl
19	F		Methyl-ethyl Ketone	gl
20	O		Adhesive-Sealant, Silicone RTV MIL-A-46106, Type I	oz

(1) Item Number	(2) Level	(3) National Stock Number	(4) Description	(5) (U/M)/ (U/I)
21	F		Lubricating Oil, Compressor, Refrigeration, (14569) Arctic 22 CC	gl
22	F		Tape, Anti-Seize MIL-T-27730, Size 1	roll

E-3/(E-4 blank)

APPENDIX F

ILLUSTRATED LIST OF MANUFACTURED ITEMS

SECTION I

F-1. SCOPE

This appendix includes complete instructions for making items authorized to be manufactured or fabricated at unit, and direct support maintenance.

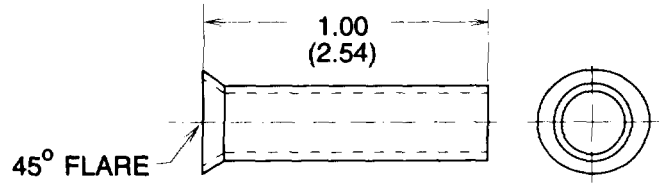
- a. A part number index in alphanumeric order is provided for cross-referencing the part number of the item to be manufactured to the figure which covers fabrication criteria.
- b. All bulk materials needed for manufacture of an item are listed by part number or specification number in a tabular list on the illustration.
- c. All dimensions are given in inches with centimeters shown in parenthesis.
- d. For fabrication information of electrical wires including lengths and markings, see Table 4-3.

SECTION II

F-2. MANUFACTURED ITEMS PART NUMBER LIST.

<u>Part Number</u>	<u>Figure Number</u>
12076-3-1000.....	F-1
13218E0001-305.....	F-2
150K0096	F-3
150K0145	F-4
150K0146	F-5
150K0159-3	F-6
150K0159-9	F-6
150K0159-11	F-6
150K0160	F-7
150K0161-1	F-8
150K0161-3	F-8
150K0169	F-9
150K0170	F-10
150K0171	F-11
150K0172	F-12
150K0175-1	F-3

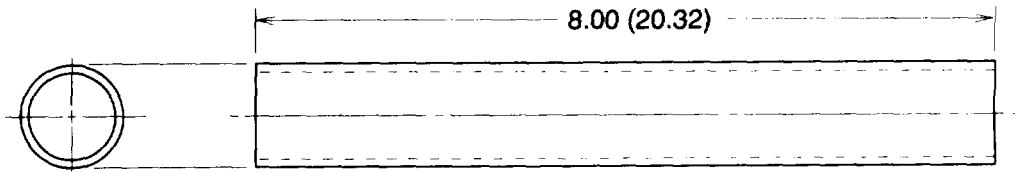
<u>Part Number</u>	<u>Figure Number</u>
150K0175-3	F-3
150K0175-5	F-3
150K0187	F-13
150K0196	F-14
150K0197	F-15
150K0198-3	F-16
150K0198-5	F-16
150K0198-7	F-16
150K0198-13	F-16
150K0200	F-17
150K0201-1/1	F-18
150K0201-1/3	F-19
150K0202	F-20
150K0203	F-21
150K0206-1/3	F-22
150K0206-5/3	F-22
151K0000-1/179	F-23
151K0000-1/180.....	F-23
151K0000-1/204.....	F-19
151K0000-1/205	F-19
151K0009-1/54	F-19
151K0028	F-24
151K0030	F-3
151K0031	F-25
151K0042-1/4	F-19
151K0043	F-26
151K0044	F-27
151K0045	F-28
151K0046-1/T	F-29
151K0047	F-30
151K0048	F-31
151K0049	F-32
151K0050	F-33
151K0051	F-34
151K0052	F-35



NOTE

- FABRICATE FROM .25 (0.64) O.D. X 0.030 (0.076) WALL ASTM B280 COPPER TUBING

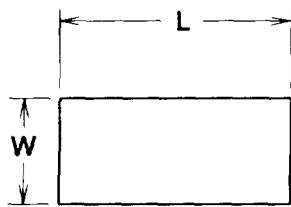
Figure F-1. Tubing-Copper, Straight Flared, Part Number 12076-3-1000



NOTE

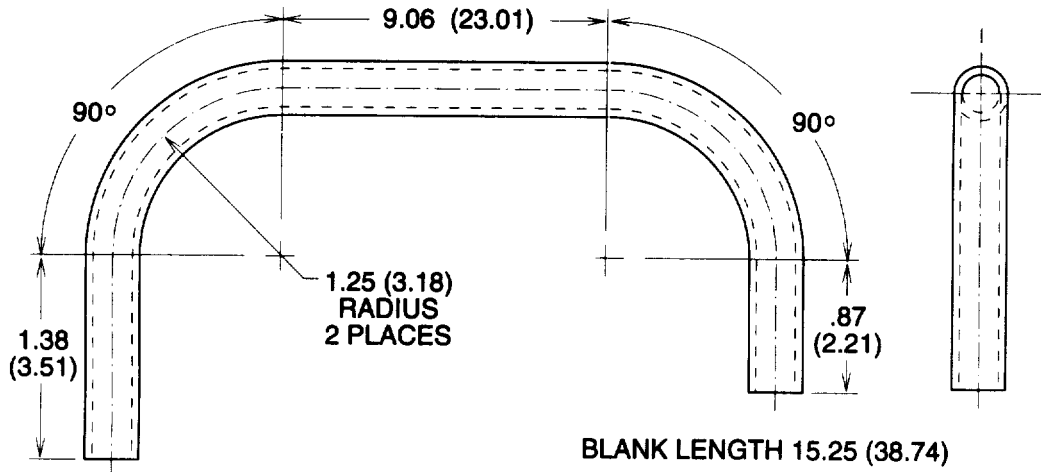
- FABRICATE FROM ZZ-T-831, TYPE VI, CLASS 6 0.75 (1.905) ID X .125 (.316) WALL PLASTIC TUBING

Figure F-2. Tubing, Plastic, Part Number 13218E0001-305



ITEM	PART NUMBER	W DIM	L DIM	FABRICATE FROM
1	150K0096	.50 (1.27)	6.84 (17.37)	ASTM D1056-2A2C2F2 0.125 (0.318) THICK RUBBER GASKET
2	150K0175-1	.88 (2.24)	8.00 (20.32)	ASTM D1056-2A2C2F2 0.125 (0.318) THICK RUBBER GASKET
3	150K0175-3	.88 (2.24)	32.69 (83.03)	ASTM D1056-2A2C2F2 0.125 (0.318) THICK RUBBER GASKET
4	150K0175-5	.84 (2.13)	34.75 (88.27)	ASTM D1056-2A2C2F2 0.125 (0.318) THICK RUBBER GASKET
5	151K0030	.50 (1.27)	5.88 (14.94)	ASTM D1056-2A2C2F2 0.125 (0.318) THICK RUBBER GASKET

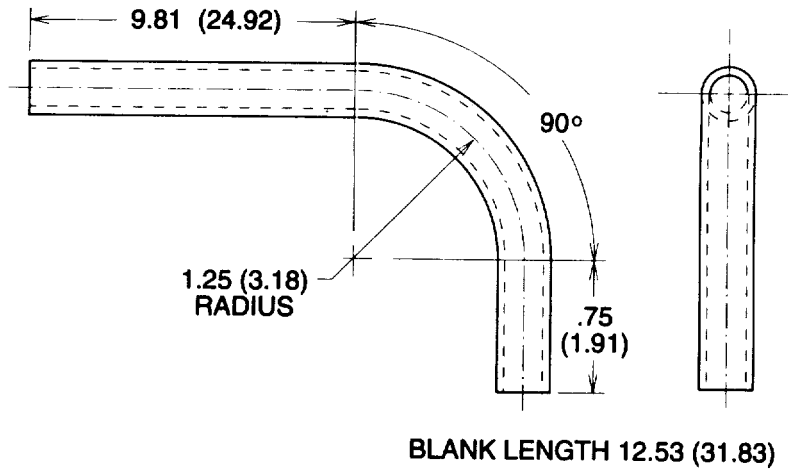
Figure F-3. Gasket, Various



NOTE

1. FABRICATE FROM 0.50 (1.27) O.D. X 0.032 (0.081) WALL ASTM B280 COPPER TUBING

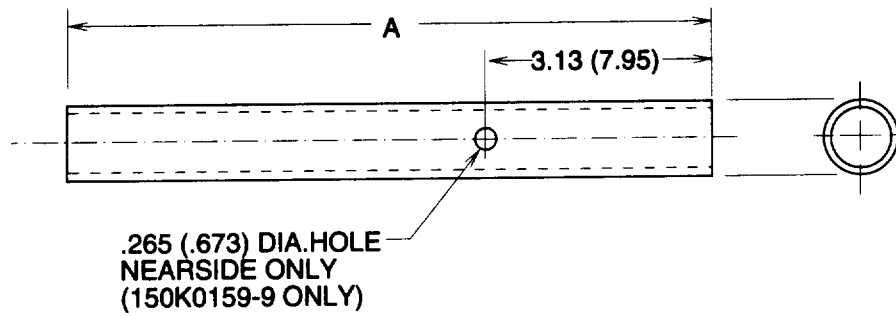
Figure F-4. Tube Distributor to Tee, Part Number 150K0145



NOTE

1. FABRICATE FROM 0.50 (1.27) O.D. X 0.032 (0.081) WALL ASTM B280 COPPER TUBING

Figure F-5. Tube, Distributor to Street Elbow, Part Number 150K0146

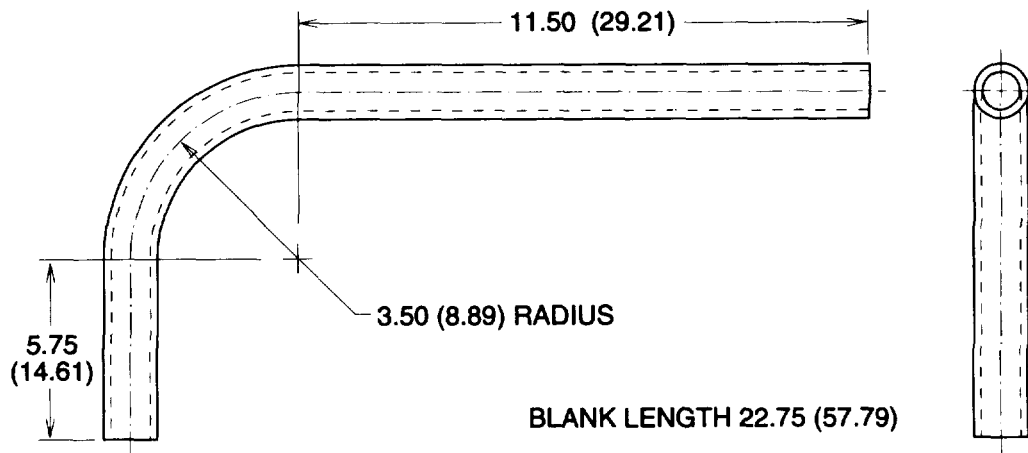


ITEM	PART NO.	DIM "A"
1	150K0159-3	4.00 (10.16)
2	150K0159-9	7.50 (19.05))
3	150K0159-11	13.00 (33.02)

NOTE

1. FABRICATE FROM 1.125 (2.857) O.D. X 0.050 (0.127) WALL ASTM B280 COPPER TUBING

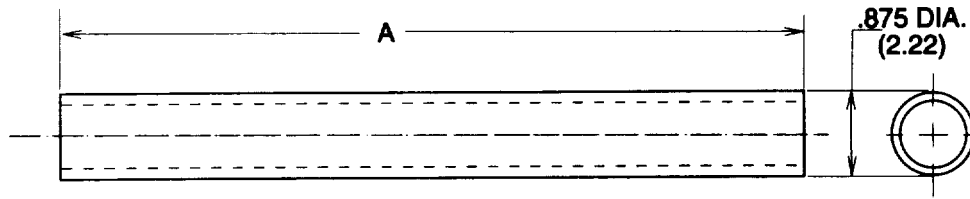
Figure F-6. Tube, Copper, Straight, Part Number 150K0159



NOTE

1. FABRICATE FROM 1.25 (3.175) O.D. X 0.050 (0.127) WALL ASTM B280 COPPER TUBING

Figure F-7. Tube, Heat Exchanger to Accumulator, Part Number 150K0160

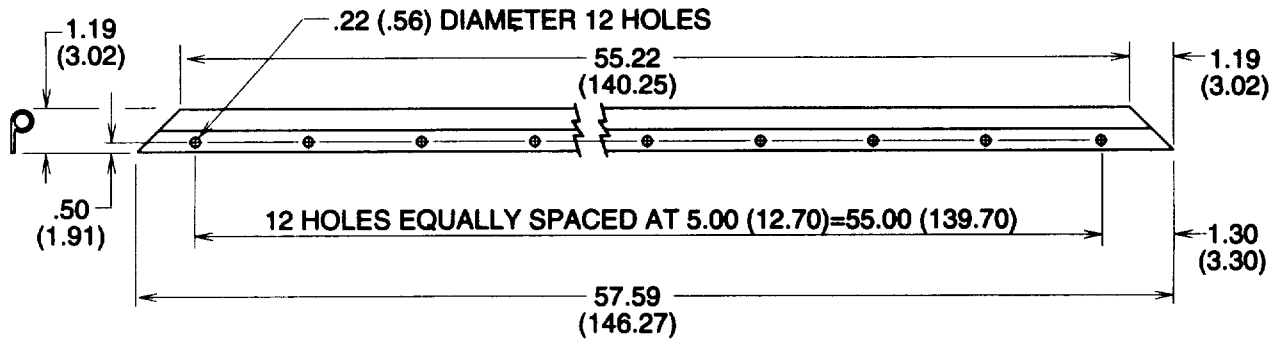


ITEM	PART NO.	DIM "A"
1	150K0161-1	26.38 (67.00)
2	150K0161-3	3.75 (9.25)

NOTE

1. FABRICATE FROM .875 (2.222) O.D. X 0.045 (0.114) WALL ASTM B280 COPPER TUBING

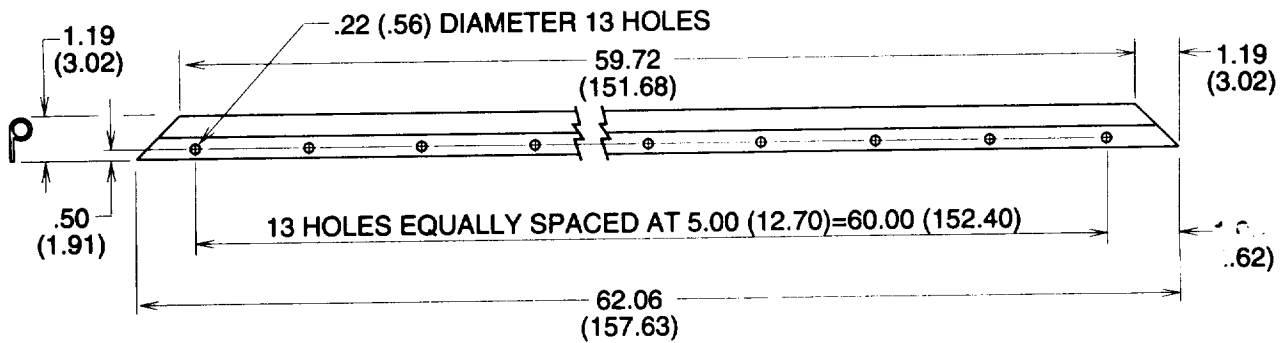
Figure F-8. Tube Copper Straight, Part Number 150K0161



NOTE

1. FABRICATE FROM (74951) V-1234-100

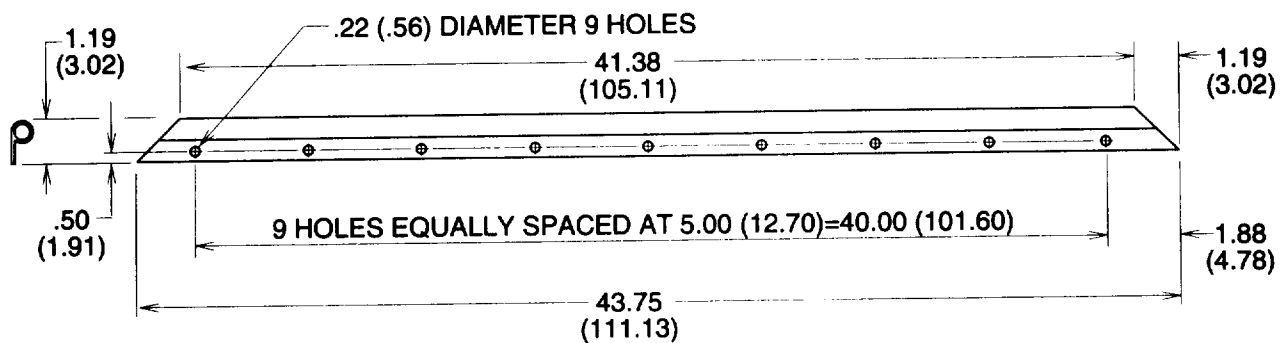
Figure F-9. Gasket, Side, Part Number 150K0169



NOTE

1. FABRICATE FROM (74951) V-1234-100

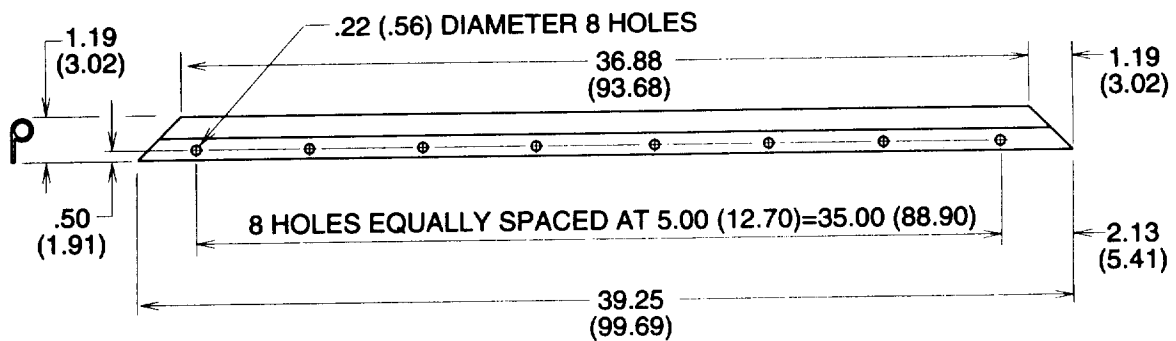
Figure F-10. Gasket, Side, Part Number 150K0170



NOTE

1. FABRICATE FROM (74951) V-1234-100

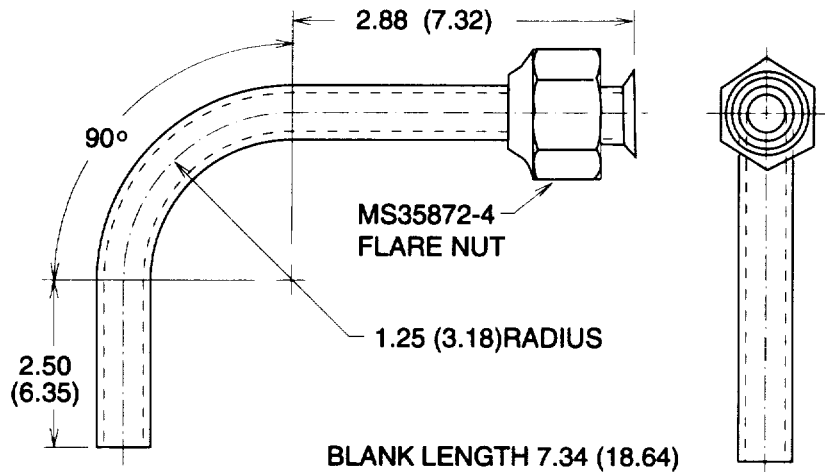
Figure F-11. Gasket, Top & Bottom, Part Number 150K0171



NOTE

1. FABRICATE FROM (74951) V-1234-100

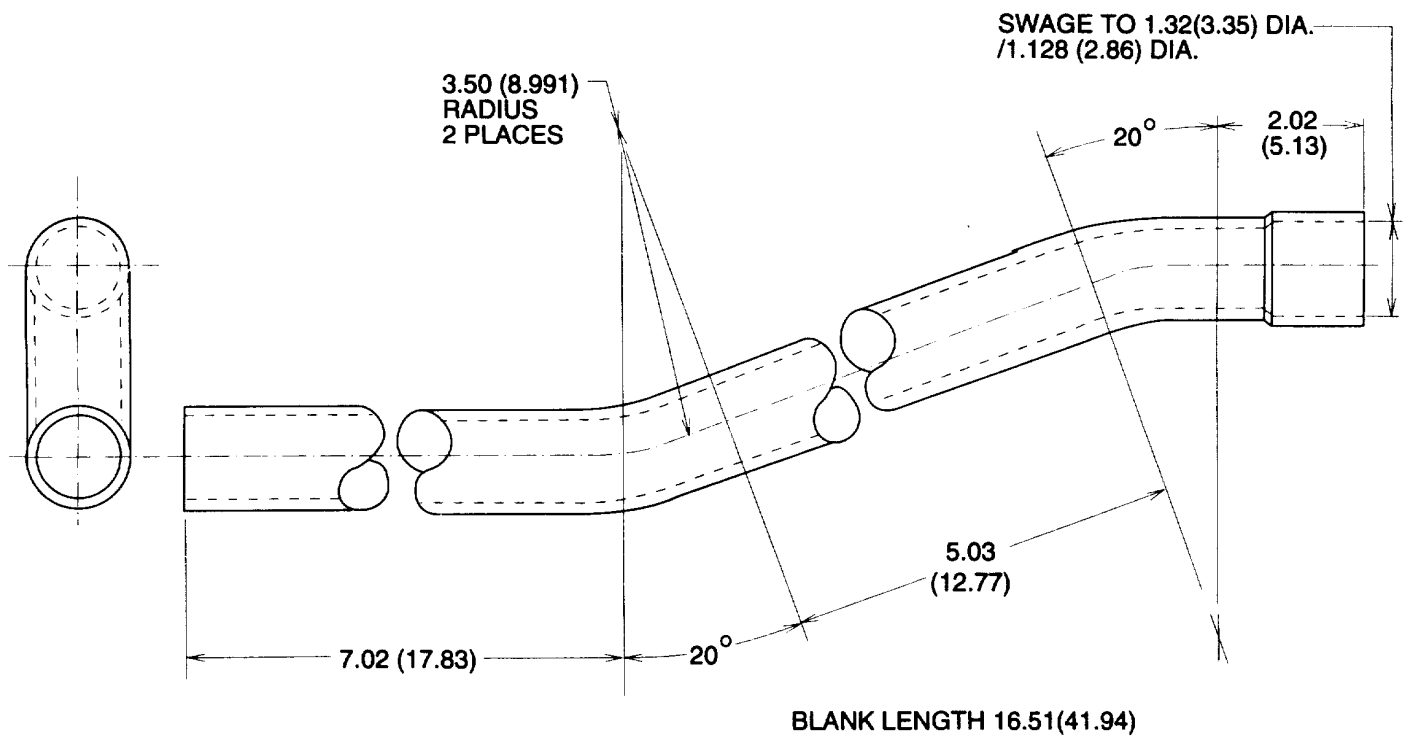
Figure F-12. Gasket, Top & Bottom, Part Number 150K0172



NOTE

1. FABRICATE FROM 0.50 (1.27) O.D. X 0.032 (0.081) WALL ASTM B280 COPPER TUBING

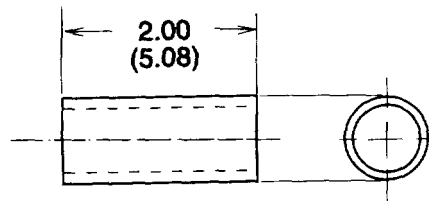
Figure F-13. Tube, Reducer to Expansion Valve, Part Number 150K0187



NOTE

1. FABRICATE FROM 1.125 (2.857) O.D. X 0.050 (0.127) WALL ASTM B280 COPPER TUBING

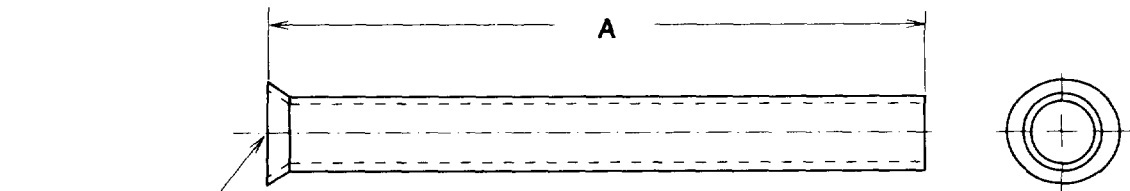
Figure F-14. Tube, Accumulator Inlet, Part Number 150K0196



NOTE

1. FABRICATE FROM 0.625 (1.59) O.D. X 0.035 (0.089) WALL ASTM B280 COPPER TUBING

Figure F-15. Tube, Reducer to Half Union Flare, Part Number 150K0197



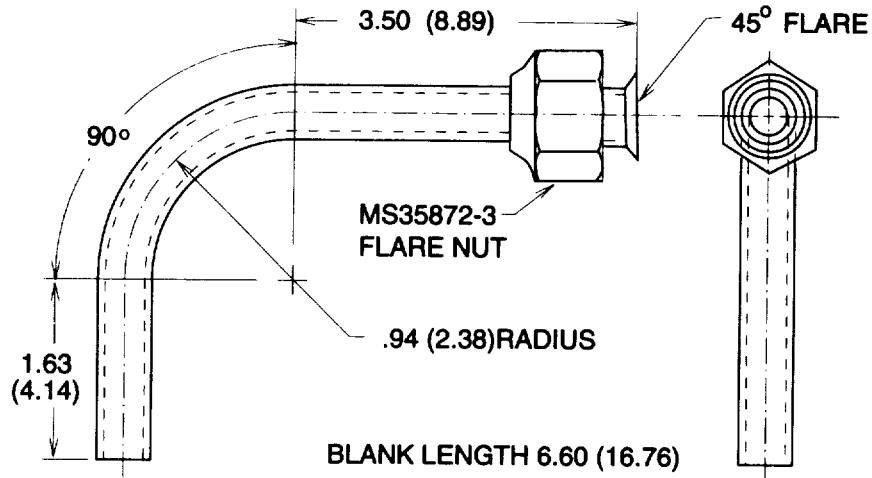
45° FLARE

ITEM	PART NO.	DIM "A"
1	150K0198-3	2.00 (5.08)
2	150K0198-5	2.25 (5.71)
3	150K0198-7	2.88 (7.32)
4	150K0198-13	6.25 (15.88)

NOTE

1. FABRICATE FROM .375 (0.952) O.D. X 0.032 (0.0812) WALL ASTM B280 COPPER TUBING

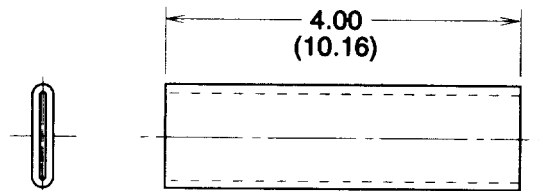
Figure F-16. Tube, Straight Flare One End, Part Number 150K0198-3, -5, -7, and -13



NOTE

1. FABRICATE FROM 0.375 (.953) O.D. X 0.032 (0.081) WALL ASTM B280 COPPER TUBING

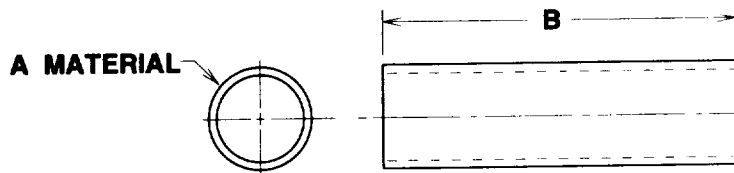
Figure F-17. Tube, Interchanger to Expansion Valve, Part Number 150K0200



NOTE

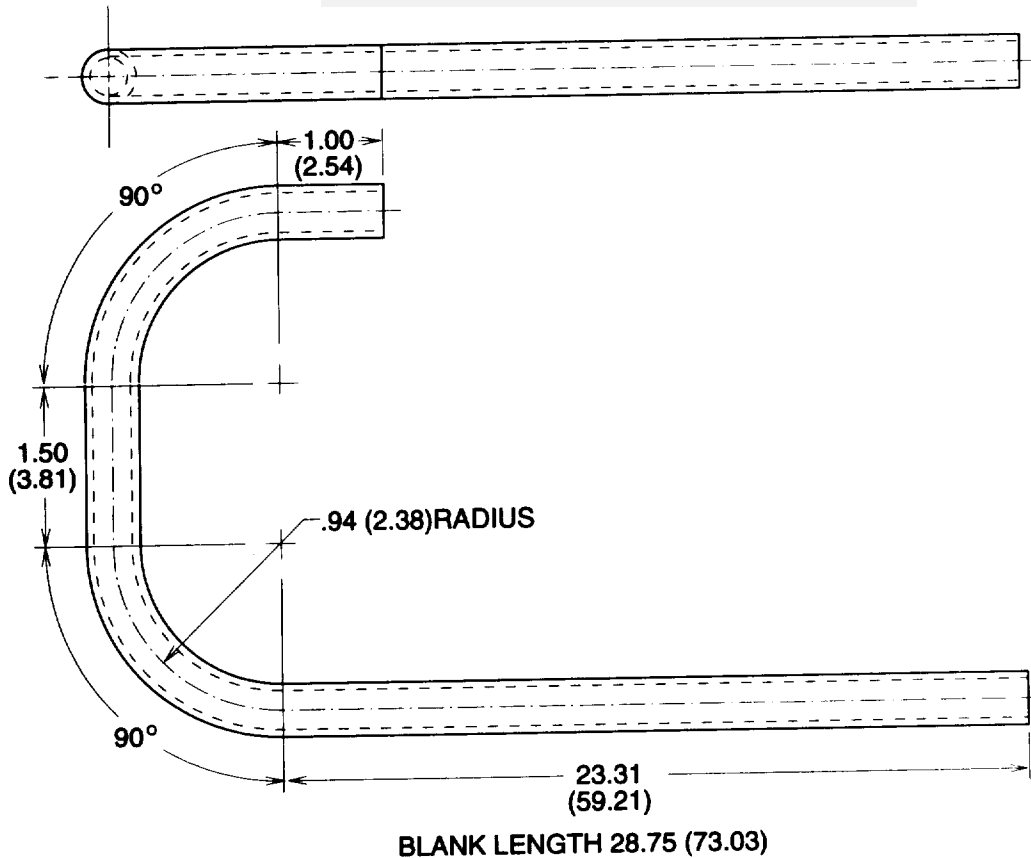
1. FABRICATE FROM QQ-B-575/R30T281

Figure F-18. Braid, Wire, Tubular, Part Number 150K0201-1/1



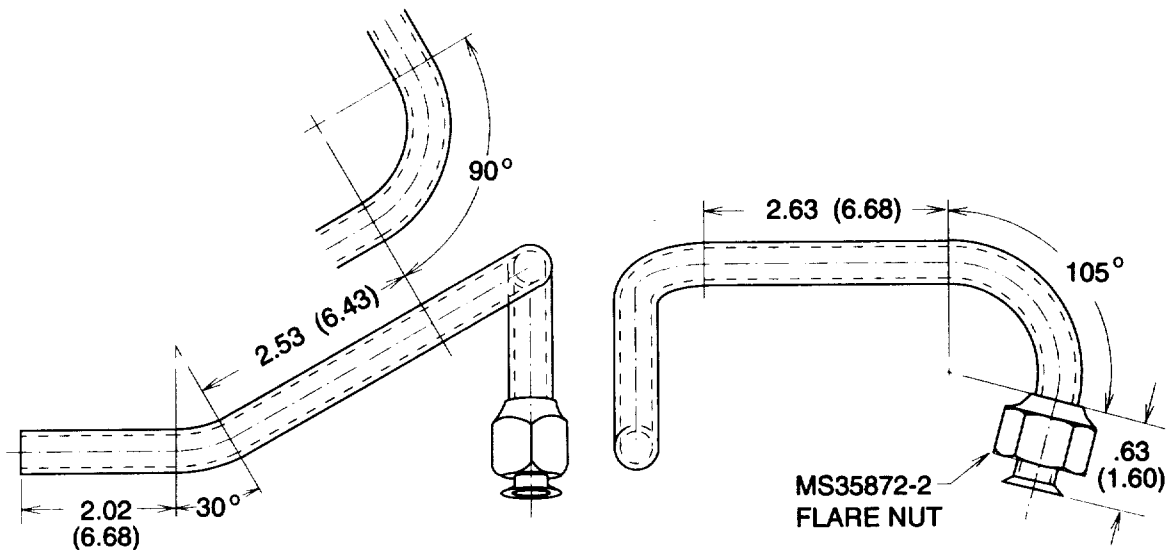
ITEM	PART NUMBER	FABRICATE FROM MATERIAL A	B LENGTH
1	150K0201-1/3	M23053/5-107-0 INSULATION, SLEEVING, HEAT SHRINKABLE	4.00 (10.16)
2	151K0000-1/204	M23053/5-106-9 INSULATION, SLEEVING, HEAT SHRINKABLE	1.50 (3.81)
3	151K0000-1/205	M23053/5-107-9 INSULATION, SLEEVING, HEAT SHRINKABLE	1.50 (3.81)
4	151K0009-1/54	M23053/5-107-9 INSULATION, SLEEVING, HEAT SHRINKABLE	.88 (2.24)
5	151K0042-1/4	M23053/5-102-0 INSULATION, SLEEVING, HEAT SHRINKABLE	1.50 (3.81)

Figure F-19. Insulation Sleeving



NOTE
 1. FABRICATE FROM 0.375 (.953) O.D. X 0.032 (0.081)
 WALL ASTM B280 COPPER TUBING

Figure F-20. Tube, Elbow to Interchanger, Part Number 150K0202

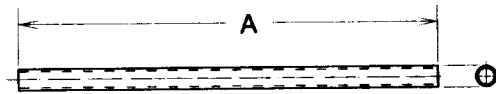


BLANK LENGTH 10.27 (26.09)

NOTE

1. FABRICATE FROM .25 (0.64) O.D. X 0.030 (0.076) WALL ASTM B280 COPPER TUBING

Figure F-21. Tube, Expansion Valve Equalizer, Part Number 150K0203

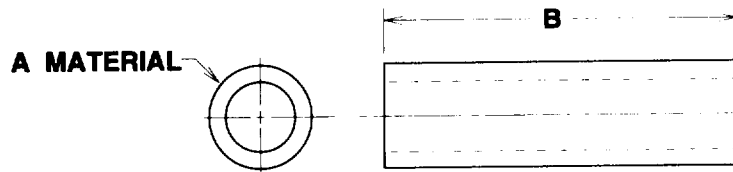


ITEM	PART NO.	DIM "A"
1	150K0206-1/3	108.00 (274.32)
2	150K0206-1/5	39.96 (101.50)

NOTE

1. FABRICATE FROM .125 (.318) O.D. X 0.030 (0.076) WALL ASTM B280 COPPER TUBING

Figure F-22. Capillary, Lines, Part Number 150K0206-1/3 & -5/3



ITEM	PART NUMBER	FABRICATE FROM MATERIAL A	B LENGTH
1	151K0000-1/179	MIL-P-15280, FORM T, 1.125 ID (2.86) X .50 (1.27) WALL INSULATION, TUBING	AS REQD
2	151K0000-1/180	MIL-P-15280, FORM T, 3.125 ID (7.94) X .50 (1.27) WALL INSULATION, TUBING	AS REQD

Figure F-23. Insulation Tubing

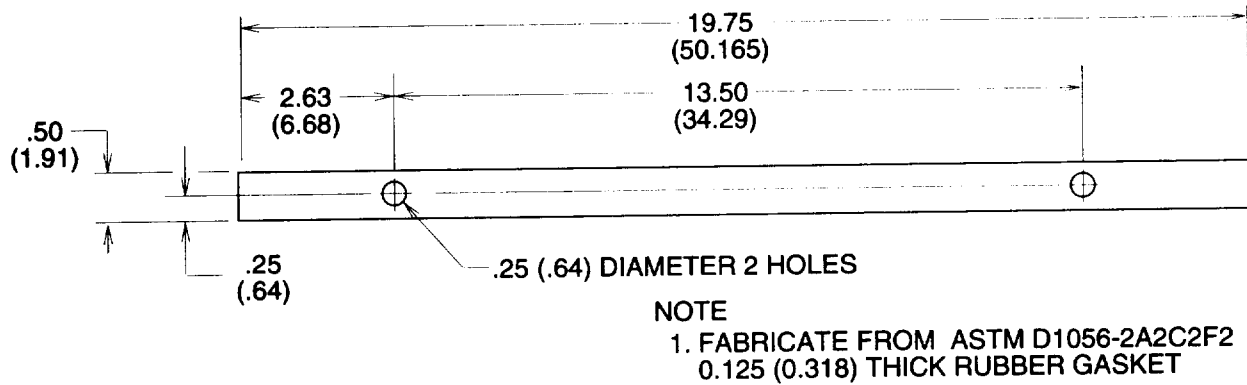


Figure F-24. Gasket, Control Box, Top, Part Number 150K0028

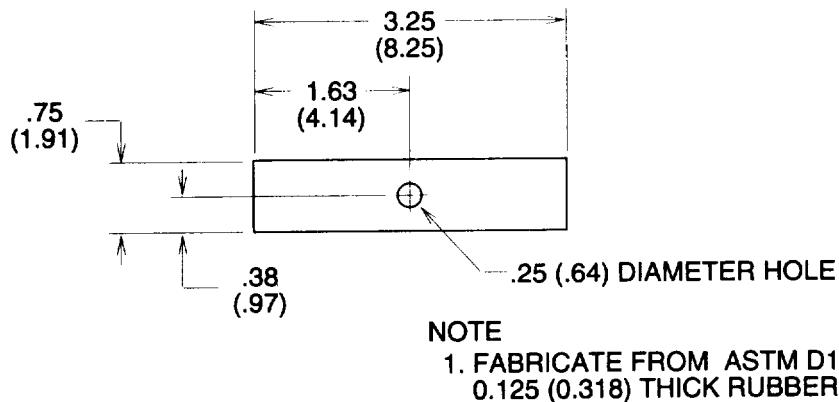
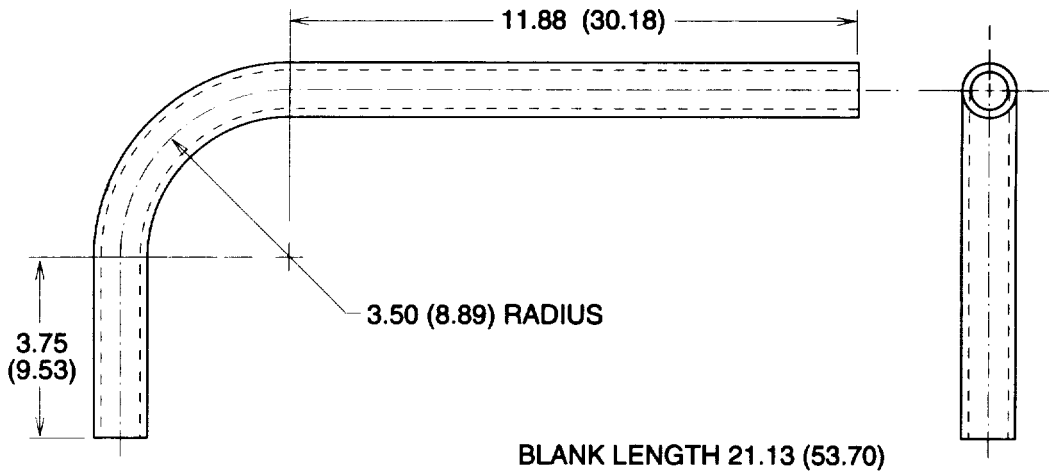


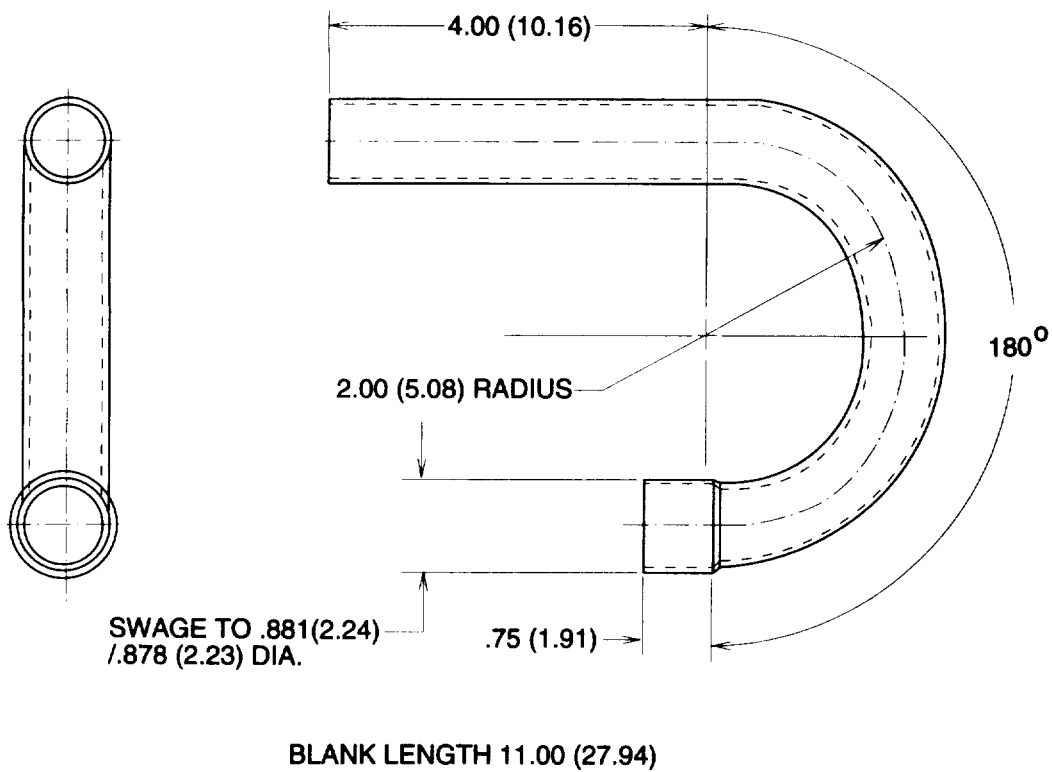
Figure F-25. Gasket, Circuit Breaker Panel, Part Number 150K0031



NOTE

1. FABRICATE FROM 1.25 (3.175) O.D. X 0.050 (0.127) WALL ASTM B280 COPPER TUBING

Figure F-26. Tube Accumulator to Regulator, Part Number 150K0043



NOTE

1. FABRICATE FROM .875 (2.222) O.D. X 0.045 (0.114) WALL ASTM B280 COPPER TUBING

Figure F-27. Tube, Condenser to Regulator, Part Number 150K0044

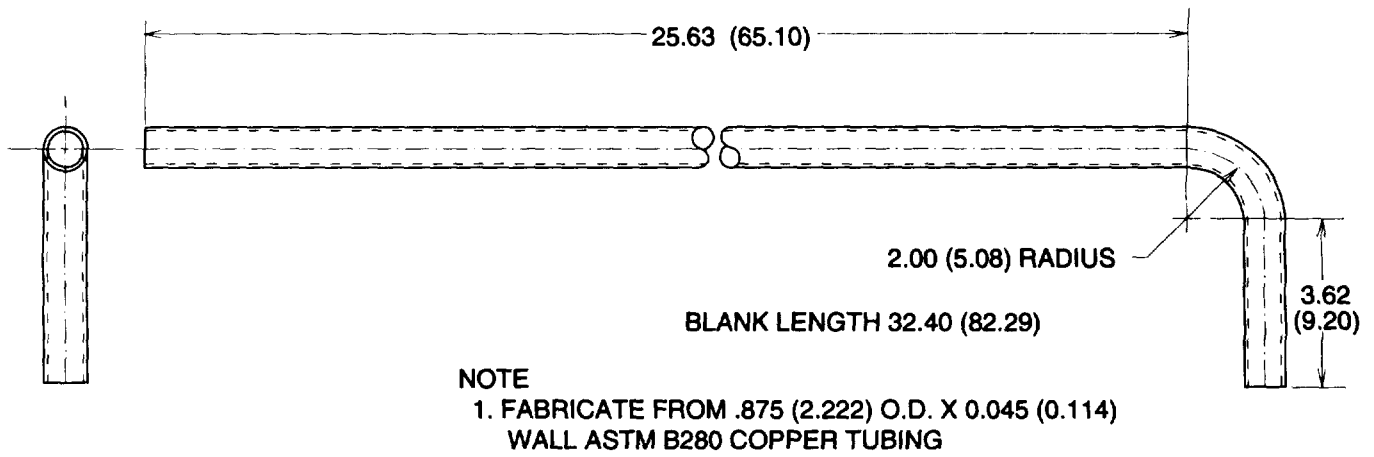


Figure F-28. Tube, Street Elbow to Vibration Absorber, Part Number 150K0045

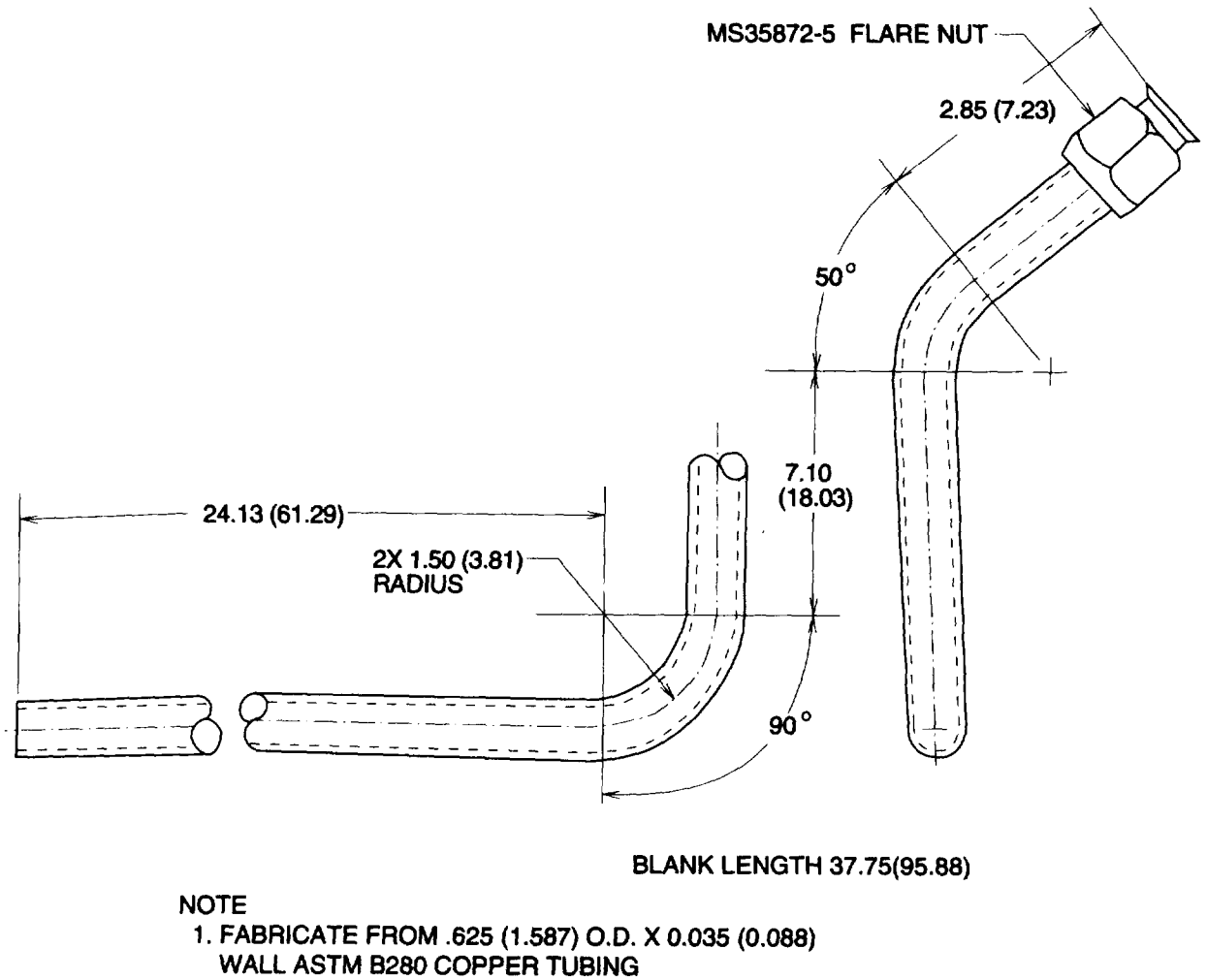
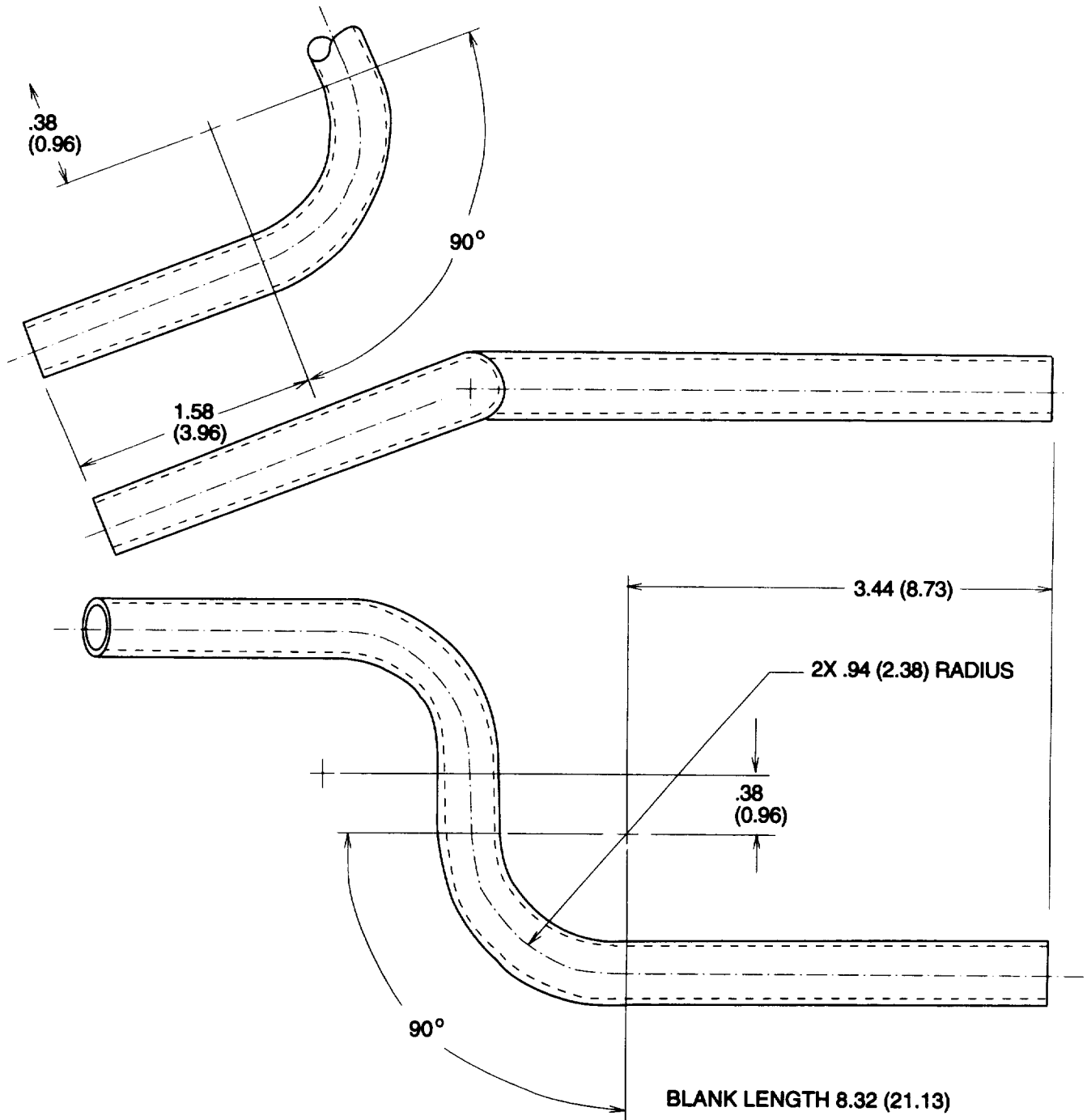


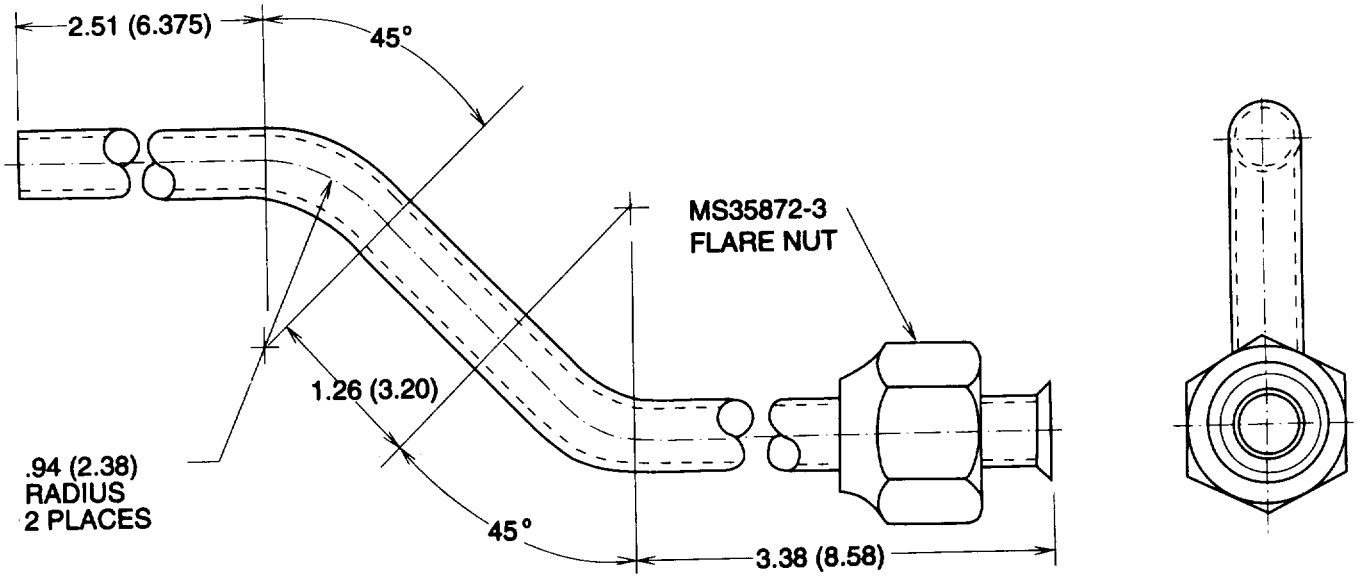
Figure F-29. Tube, Receiver Inlet, Part Number 150K0046-1T



NOTE

1. FABRICATE FROM .375 (0.952) O.D. X 0.032 (0.081) WALL ASTM B280 COPPER TUBING

Figure F-30. Tube, Tee to Hand Valve, Part Number 150K0047

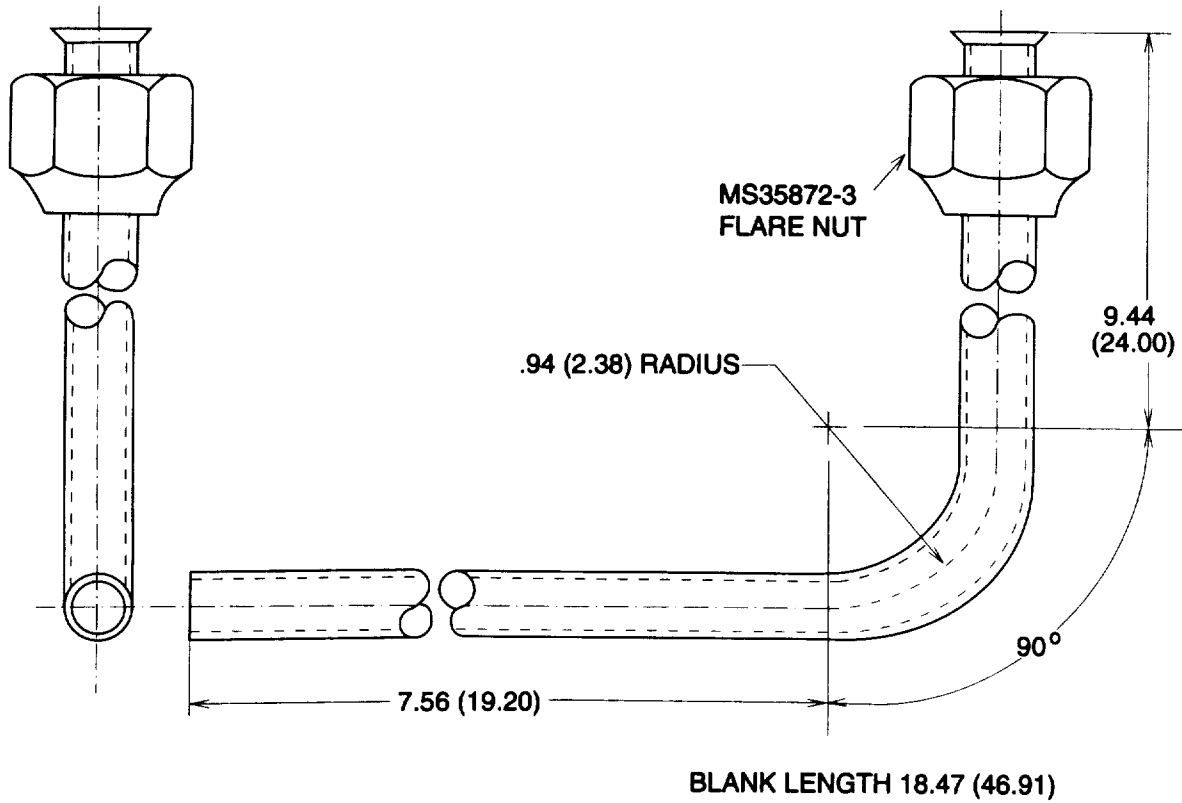


BLANK LENGTH 8.63 (21.92)

NOTE

1. FABRICATE FROM .375 (0.952) O.D. X 0.032 (0.0812) WALL ASTM B280 COPPER TUBING

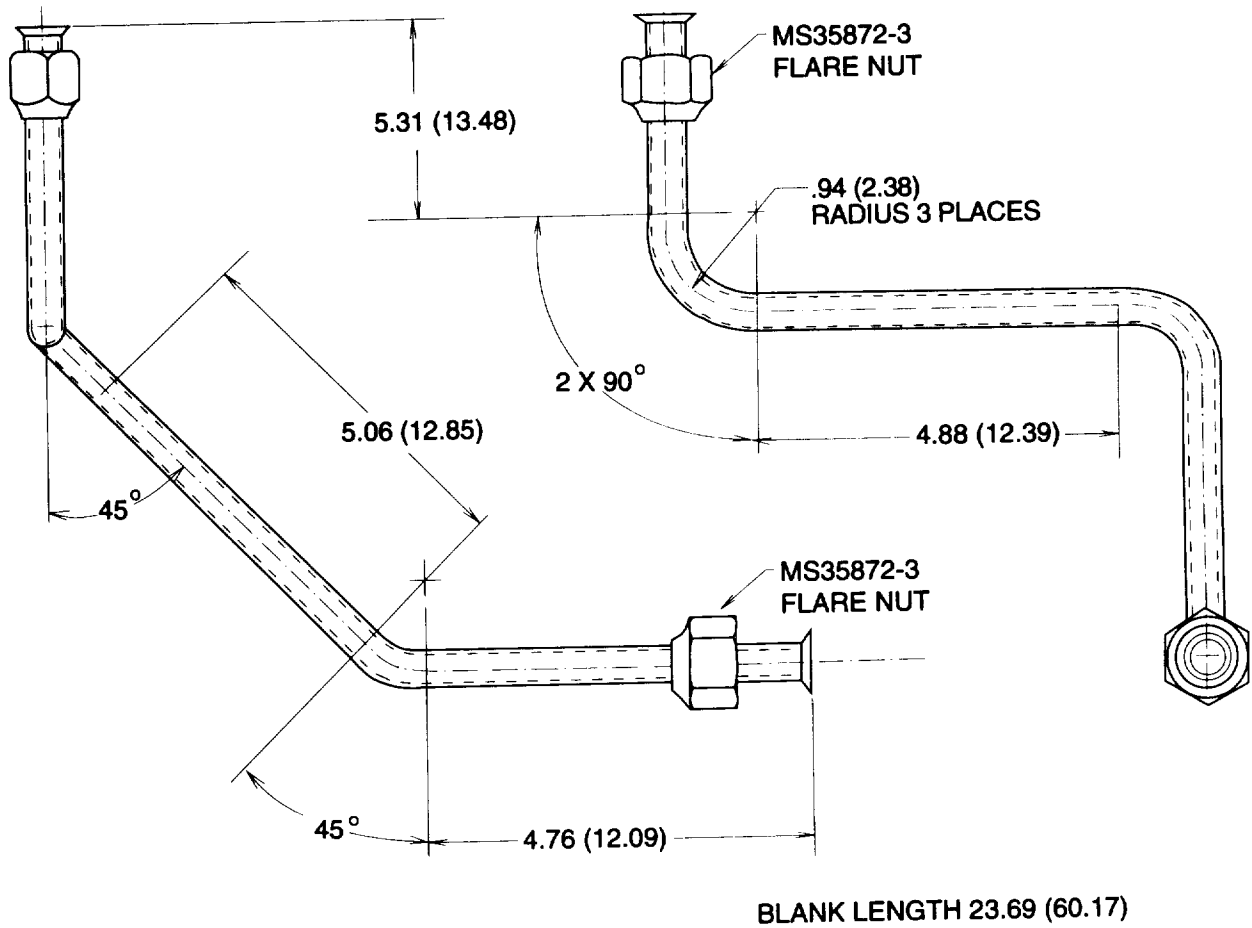
Figure F-31. Tube, Straight Flare One End, Part Number 150K0048



NOTE

1. FABRICATE FROM .375 (0.952) O.D. X 0.032 (0.0812) WALL ASTM B280 COPPER TUBING

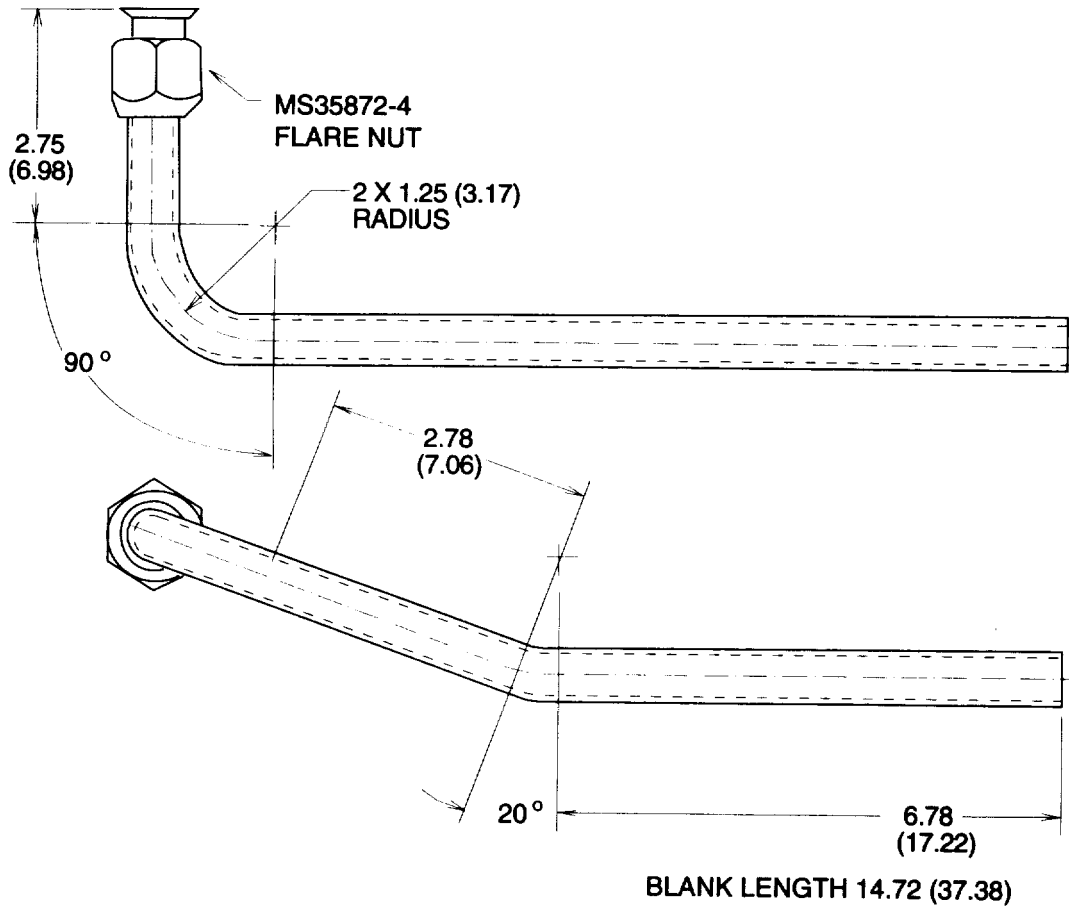
Figure F-32. Tube, Sight Glass to Elbow, Part Number 150K0049



NOTE

1. FABRICATE FROM .375 (.952) O.D. X 0.032 (0.081) WALL ASTM B280 COPPER TUBING

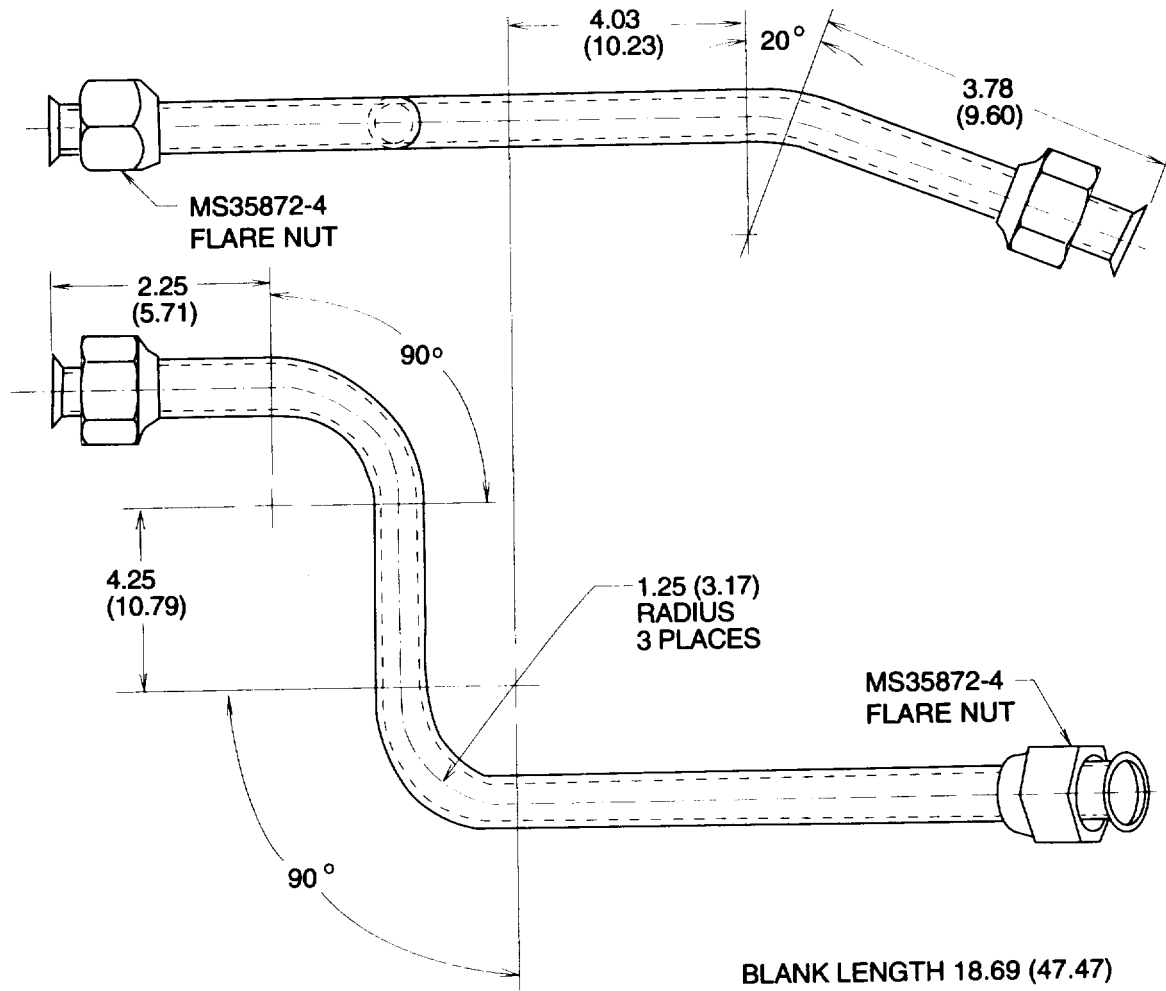
Figure F-33. Tube, Strainer to Solenoid Valve, Part Number 150K0050



NOTE

1. FABRICATE FROM .500 (1.27) O.D. X 0.032 (0.081) WALL ASTM B280 COPPER TUBING

Figure F-34. Tube, Filter Drier Outlet, Part Number 150K0051



NOTE
1. FABRICATE FROM .500 (1.27) O.D. X 0.032 (0.081)
WALL ASTM B280 COPPER TUBING

Figure F-35. Tube, Receiver to Filter Drier, Part Number 150K0052

F-21/(F-22 blank)

APPENDIX G

MANDATORY REPLACEMENT PARTS

Item	Nomenclature	Part Number	
1	Lock Washer	500K1950-3	(94833)
2	Seal	020-0844-01	(14569)
3	Lock Washer	500K1950-2	(94833)
4	Rivet	13214E3789-2	(97403)
5	Rivet	13214E3789-4	(97403)
6	Lock Washer	500K1950-1	(94833)
7	Lock Washer	500K1950-5	(94833)
8	Self Locking Nut	500K1927-1	(94833)
9	Tie Down Strap	MS3367-4-9	(96906)
10	Tie Down Strap	MS3367-2-9	(96906)
11	Self Locking Nut	52054-9	(94833)
12	Self Locking Nut	500K1927-3	(94833)
13	Lock Washer	500K1950-4	(94833)
14	Self Locking Nut	500K1927-2	(94833)
15	Self Locking Nut	500K1927-5	(94833)
16	Lock Washer	500K1950-6	(94833)
17	Self Locking Nut	500K1927-6	(94833)
18	Oil Pump Gasket	020-0732-00	(14569)
19	Locknut	101-0006-00	(14569)
20	Gasket	020-0012-11	(14569)
21	Gasket	020-0012-09	(14569)
22	Gasket	020-0756-00	(14569)

Item	Nomenclature	Part Number	
23	Gasket	020-0757-04	(14569)
24	Sight Glass	570-0020-00	(14569)
25	Self Locking Nut	500K1927-4	(94833)
26	Fused Cluster Terminal	521-0018-00	(14569)
27	Fused Cluster Seal	020-0844-00	(14569)
28	Terminal Mounting Plate Gasket	503-0346-01	(14569)

ALPHABETICAL INDEX

A

AC Motor B2 Testing and Replacement4-35

Accumulator Replacement5-31

Administrative Storage.....4-45

Air Handling System.....1-15

Assembly and Preparation for Use2-4

B

Brazing/Debraze Procedure5-10

C

Charging the Refrigerant System5-13

Circuit Breaker CB1 Testing and Replacement.....4-21

Circuit Breaker Cover Repair5-3

Cleaning.....3-4

Common Tools and Equipment4-1

Compound Gage Replacement5-16

Compressor B1 Testing, Repair, and Replacement5-38

Condenser Coil Replacement.....5-20

Condenser Fan Replacement.....4-37

Condenser Frame Repair5-39, 6-2

Condenser Guard Replacement4-19

Condenser Side Doors and Barrel Bolts Replacement4-14

Condenser Top Panel Replacement4-13

Contactors (Power Relay) K2 Testing and Replacement4-25

Control Box Cover Repair5-4

Control Panel Cover Repair5-2

Control Panel Cover, Door Holder Clips, and Barrel Bolts Replacement4-16

Control Relays K3 and K4 Testing and Replacement4-26

Corrosion Prevention and Control1-9

D

Decals and Instruction Plates2-8

Defrost Temperature Switch S4 Testing and Replacement4-32

Dehydrator Replacement.....5-15

Destruction of Army Material to Prevent Enemy Use1-3

Differential Oil Pressure Switch S5 Replacement5-36

Discharging the Refrigerant System5-8

Dual Pressure Control Switch S2 Replacement5-37

E

Electrical System1-13

Equipment Characteristics, Capabilities and Features1-10

Equipment Data1-12

Evacuating the Refrigerant System5-12

Evaporator Air Outlet Guard Replacement4-17

Evaporator Coil Guard Replacement.....4-18

Evaporator Coil Replacement5-35

Evaporator Fan Replacement.....4-38

Expansion Valve Replacement.....5-34

F

Fan Drive Shaft Replacement5-5

Fault Controls and Indicators.....2-2

Flange Bearings Replacement4-39

Front Bottom Doors and Barrel Bolts Replacement4-15

Fuses F1 and F2 Testing and Replacement4-23

G
 Gasket (Heat Shield) Replacement4-44
 General.....2-3, 3-3, 4-10, 6-1

H
 Heat Exchanger Replacement.....5-33
 Hourmeter MI Testing and Replacement4-27

I
 Indicators DS1 Testing and Replacement.....4-22
 Installation Instructions.....4-6
 Isolation Valves Replacement5-30

L
 Leak Testing the Refrigerant System.....5-11
 Location and Description of Major Components.....1-11
 Long Term Storage or Shipment4-46
 Lubrication3-1, 4-9

M
 Maintenance Forms, Records and Reports.....1-2
 Mandatory Replacement Parts4-11
 Metal Hose Assembly (Discharge)
 Replacement5-23
 Metal Hose Assembly (Suction) Replacement5-24
 Motor Starter K1 Testing, Repair, and
 Replacement4-24

N
 NBC Decontamination Procedures2-10

O
 Official Nomenclature, Names and
 Designations1-6
 Operating Controls and Indicators2-1
 Operation Under Inclement Weather2-9
 Operator Checks2-6

P
 Power Distribution Block TB2 Testing and
 Replacement4-33
 Preliminary Adjustment of Equipment4-8
 Preliminary Servicing of Equipment4-7
 Preparation for Storage or Shipment1-4
 Pressure Gage Replacement5-17
 Pressure Regulator Valve (Crankcase)
 Replacement5-22
 Pressure Regulator Valve (Discharge)
 Replacement5-21
 Pulley Replacement4-40
 Purging the Refrigerant System5-9
 Push Switches S6 and S7 Testing and
 Replacement4-34

Q
 Quality Assurance1-5

R
 Receiver Replacement.....5-19
 Refrigerant System Pressure Check.....5-14
 Refrigeration System Repairs.....5-6
 Refrigeration System.....1-14
 Remote Bulb Thermostat S3 Testing and
 Replacement4-30
 Repair Parts4-3
 Repeat Cycle Timer TM1 Testing and
 Replacement4-29
 Reporting Equipment Improvement
 Recommendations (EIR).....1-7

S

Scope 1-1
 Service Manifold Installation 5-7
 Service Upon Receipt of Material 4-5
 Sheave Replacement 4-41
 Shutdown Procedures 2-7
 Sight Indicator Replacement 5-27
 Site and Shelter Requirements 4-4
 Solenoid Valve L1 (Liquid Line) Testing and
 Repair 4-42
 Solenoid Valve L2 (Defrost Line) Testing and
 Repair 4-43
 Solenoid Valve L1 (Liquid Line) Replacement 5-28
 Solenoid Valve L2 (Defrost Line) Replacement 5-29
 Special Tools, TMDE, and Support Equipment 4-2
 Startup Procedures 2-5
 Stop Valve (Defrost Line) Replacement 5-26
 Stop Valve (Liquid Line) Replacement 5-25
 Strainer Replacement 5-18

T

Thermometer Testing and Replacement 4-31
 Toggle Switch S1 Testing and Replacement 4-28
 Troubleshooting 3-2, 4-12, 5-1
 Tubing and Fittings Testing, Repair, and
 Replacement 5-32

V

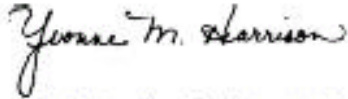
V Belt Replacement and Adjustment 4-36

W

Warranty Information 1-8
 Wires, Cables, and Harnesses Testing, Repair,
 and Replacement 4-20

By Order of the Secretary of the Army:

Official:



Administrative Assistant to the
Secretary of the Army
01282

DENNIS J. REIMER
General, United States Army
Chief of Staff

DISTRIBUTION:

To be distributed in accordance with DA Form 12-25-E, block no. 6314, requirements for TM 9-4110-256-14.

These are the instructions for sending an electronic 2028

The following format must be used if submitting an electronic 2028. The subject line must be exactly the same and all fields must be included; however only the following fields are mandatory: 1, 3, 4, 5, 6, 7, 8, 9, 10, 13, 15, 16, 17, and 27.

From: "Whomever" <whomever@avma27.army.mil>

To: amsbriml@natick.army.mil

Subject: DA Form 2028

1. From: Joe Smith
2. Unit: home
3. Address: 4300 Park
4. City: Hometown
5. St: MO
6. Zip: 77777
7. Date Sent: 19-OCT-93
8. Pub no: 55-2840-229-23
9. Pub Title: TM
10. Publication Date: 04-JUL-85
11. Change Number: 7
12. Submitter Rank: MSG
13. Submitter FName: Joe
14. Submitter MName: T
15. Submitter LName: Smith
16. Submitter Phone: 123-123-1234
17. Problem: 1
18. Page: 2
19. Paragraph: 3
20. Line: 4
21. NSN: 5
22. Reference: 6
23. Figure: 7
24. Table: 8
25. Item: 9
26. Total: 123
27. Text:

This is the text for the problem below line 27.

RECOMMENDED CHANGES TO PUBLICATIONS AND BLANK FORMS For use of this form, see AR 25-30; the proponent agency is ODISC4.						Use Part II (reverse) for Repair Parts and Special Tool Lists (RPSTL) and Supply Catalogs/Supply Manuals (SC/SM).	DATE 21 October 2003
TO: (Forward to proponent of publication or form) (Include ZIP Code) COMMANDER U.S. ARMY TANK-AUTOMOTIVE AND ARMAMENT COMMAND ATTN: AMSTA-LC-CECT 15 KANSAS STREET NATICK, MA 01760-5052						FROM: (Activity and location) (Include ZIP Code) <i>PFC Jane Doe</i> <i>CO A 3rd Engineer BR</i> <i>Ft. Leonardwood, MO 63108</i>	
PART I – ALL PUBLICATIONS (EXCEPT RPSTL AND SC/SM) AND BLANK FORMS							
PUBLICATION/FORM NUMBER TM 10-1670-296-23&P				DATE 30 October 2002	TITLE Unit Manual for Ancillary Equipment for Low Velocity Air Drop Systems		
ITEM NO.	PAGE NO.	PARA-GRAPH	LINE NO. *	FIGURE NO.	TABLE NO.	RECOMMENDED CHANGES AND REASON <i>(Provide exact wording of recommended changes, if possible).</i>	
	0036 00-2				1	<i>In table 1, Sewing Machine Code Symbols, the second sewing machine code symbol should be MD ZZ not MD 22.</i> <i>Change the manual to show Sewing Machine, Industrial: Zig-Zag; 308 stitch; medium-duty; NSN 3530-01-181-1421 as a MD ZZ code symbol.</i>	
<small>*Reference to line numbers within the paragraph or subparagraph.</small>							
TYPED NAME, GRADE OR TITLE Jane Doe, PFC				TELEPHONE EXCHANGE/AUTOVON, PLUS EXTENSION 508-233-4141		SIGNATURE Jane Doe <i>Jane Doe</i>	

TO: (Forward direct to addressee listed in publication) COMMANDER U.S. ARMY TANK-AUTOMOTIVE AND ARMAMENT COMMAND ATTN: AMSTA-LC-CECT 15 KANSAS STREET NATICK, MA 01760-5052	FROM: (Activity and location) (Include ZIP Code) <i>PFC Jane Doe</i> <i>CO A 3rd Engineer BR</i> <i>Ft. Leonardwood, MO 63108</i>	DATE 21 October 2003
---	--	--------------------------------

PART II – REPAIR PARTS AND SPECIAL TOOL LISTS AND SUPPLY CATALOGS/SUPPLY MANUALS

PUBLICATION NUMBER TM 10-1670-296-23&P	DATE 30 October 2002	TITLE Unit Manual for Ancillary Equipment for Low Velocity Air Drop Systems
--	--------------------------------	---

PAGE NO.	COLM NO.	LINE NO.	NATIONAL STOCK NUMBER	REFERENCE NO.	FIGURE NO.	ITEM NO.	TOTAL NO. OF MAJOR ITEMS SUPPORTED	RECOMMENDED ACTION
0066 00-1					4			<i>Callout 16 in figure 4 is pointed to a <u>D-Ring</u>. In the Repair Parts List key for figure 4, item 16 is called a <u>Snap Hook</u>. Please correct one or the other.</i>

PART III – REMARKS (Any general remarks or recommendations, or suggestions for improvement of publications and blank forms. Additional blank sheets may be used if more space is needed.)

--	--	--

TYPED NAME, GRADE OR TITLE	TELEPHONE EXCHANGE/AUTOVON, PLUS EXTENSION	SIGNATURE
----------------------------	--	-----------

RECOMMENDED CHANGES TO PUBLICATIONS AND BLANK FORMS						Use Part II (reverse) for Repair Parts and Special Tool Lists (RPSTL) and Supply Catalogs/Supply Manuals (SC/SM).	DATE
For use of this form, see AR 25-30; the proponent agency is ODISC4.							
TO: (Forward to proponent of publication or form) (Include ZIP Code) Commander U.S. Army Tank-automotive and Armament Command ATTN: AMSTA-LC-CECT Kansas Street, Natick, MA 01760-5052.						FROM: (Activity and location) (Include ZIP Code)	
PART I – ALL PUBLICATIONS (EXCEPT RPSTL AND SC/SM) AND BLANK FORMS							
PUBLICATION/FORM NUMBER TM 9-4110-256-14				DATE 5 January 1996		TITLE Operator's, Unit, Direct Support, and General Support Maintenance Manual Refrigeration Unit, Mechanical, 10K BTU, Electric, Model F10000RE	
ITEM NO.	PAGE NO.	PARA-GRAPH	LINE NO. *	FIGURE NO.	TABLE NO.	RECOMMENDED CHANGES AND REASON <i>(Provide exact wording of recommended changes, if possible).</i>	
<i>*Reference to line numbers within the paragraph or subparagraph.</i>							
TYPED NAME, GRADE OR TITLE				TELEPHONE EXCHANGE/AUTOVON, PLUS EXTENSION		SIGNATURE	

TO: <i>(Forward direct to addressee listed in publication)</i> Commander U.S. Army Tank-automotive and Armament Command ATTN: AMSTA-LC-CECT Kansas Street, Natick, MA 01760-5052.	FROM: <i>(Activity and location) (Include ZIP Code)</i>	DATE
--	--	-------------

PART II – REPAIR PARTS AND SPECIAL TOOL LISTS AND SUPPLY CATALOGS/SUPPLY MANUALS

PUBLICATION NUMBER TM 9-4110-256-14	DATE 5 January 1996	TITLE Operator's, Unit, Direct Support, and General Support Maintenance Manual Refrigeration Unit, Mechanical, 10K BTU, Electric, Model F10000RE
---	-------------------------------	---

PAGE NO.	COLM NO.	LINE NO.	NATIONAL STOCK NUMBER	REFERENCE NO.	FIGURE NO.	ITEM NO.	TOTAL NO. OF MAJOR ITEMS SUPPORTED	RECOMMENDED ACTION

PART III – REMARKS *(Any general remarks or recommendations, or suggestions for improvement of publications and blank forms. Additional blank sheets may be used if more space is needed.)*

TYPED NAME, GRADE OR TITLE	TELEPHONE EXCHANGE/AUTOVON, PLUS EXTENSION	SIGNATURE
----------------------------	--	-----------

RECOMMENDED CHANGES TO PUBLICATIONS AND BLANK FORMS						Use Part II (reverse) for Repair Parts and Special Tool Lists (RPSTL) and Supply Catalogs/Supply Manuals (SC/SM).	DATE
For use of this form, see AR 25-30; the proponent agency is ODISC4.							
TO: (Forward to proponent of publication or form) (Include ZIP Code) Commander U.S. Army Tank-automotive and Armament Command ATTN: AMSTA-LC-CECT Kansas Street, Natick, MA 01760-5052.						FROM: (Activity and location) (Include ZIP Code)	
PART I – ALL PUBLICATIONS (EXCEPT RPSTL AND SC/SM) AND BLANK FORMS							
PUBLICATION/FORM NUMBER TM 9-4110-256-14				DATE 5 January 1996		TITLE Operator's, Unit, Direct Support, and General Support Maintenance Manual Refrigeration Unit, Mechanical, 10K BTU, Electric, Model F10000RE	
ITEM NO.	PAGE NO.	PARA-GRAPH	LINE NO. *	FIGURE NO.	TABLE NO.	RECOMMENDED CHANGES AND REASON <i>(Provide exact wording of recommended changes, if possible).</i>	
<i>*Reference to line numbers within the paragraph or subparagraph.</i>							
TYPED NAME, GRADE OR TITLE				TELEPHONE EXCHANGE/AUTOVON, PLUS EXTENSION		SIGNATURE	

TO: <i>(Forward direct to addressee listed in publication)</i> Commander U.S. Army Tank-automotive and Armament Command ATTN: AMSTA-LC-CECT Kansas Street, Natick, MA 01760-5052.	FROM: <i>(Activity and location) (Include ZIP Code)</i>	DATE
--	--	-------------

PART II – REPAIR PARTS AND SPECIAL TOOL LISTS AND SUPPLY CATALOGS/SUPPLY MANUALS

PUBLICATION NUMBER TM 9-4110-256-14	DATE 5 January 1996	TITLE Operator's, Unit, Direct Support, and General Support Maintenance Manual Refrigeration Unit, Mechanical, 10K BTU, Electric, Model F10000RE
---	-------------------------------	---

PAGE NO.	COLM NO.	LINE NO.	NATIONAL STOCK NUMBER	REFERENCE NO.	FIGURE NO.	ITEM NO.	TOTAL NO. OF MAJOR ITEMS SUPPORTED	RECOMMENDED ACTION

PART III – REMARKS *(Any general remarks or recommendations, or suggestions for improvement of publications and blank forms. Additional blank sheets may be used if more space is needed.)*

TYPED NAME, GRADE OR TITLE	TELEPHONE EXCHANGE/AUTOVON, PLUS EXTENSION	SIGNATURE
----------------------------	--	-----------

The Metric System and Equivalents

Linear Measure

1 centimeter = 10 millimeters = .39 inch
 1 decimeter = 10 centimeters = 3.94 inches
 1 meter = 10 decimeters = 39.37 inches
 1 dekameter = 10 meters = 32.8 feet
 1 hectometer = 10 dekameters = 328.08 feet
 1 kilometer = 10 hectometers = 3,280.8 feet

Weights

1 centigram = 10 milligrams = .15 grain
 1 decigram = 10 centigrams = 1.54 grains
 1 gram = 10 decigrams = .035 ounce
 1 decagram = 10 grams = .35 ounce
 1 hectogram = 10 decagrams = 3.52 ounces
 1 kilogram = 10 hectograms = 2.2 pounds
 1 quintal = 100 kilograms = 220.46 pounds
 1 metric ton = 10 quintals = 1.1 short tons

Liquid Measure

1 centiliter = 10 milliliters = .34 fl. ounce
 1 deciliter = 10 centiliters = 3.38 fl. ounces
 1 liter = 10 deciliters = 33.81 fl. ounces
 1 dekaliter = 10 liters = 2.64 gallons
 1 hectoliter = 10 dekaliters = 26.42 gallons
 1 kiloliter = 10 hectoliters = 264.18 gallons

Square Measure

1 sq. centimeter = 100 sq. millimeters = .155 sq. inch
 1 sq. decimeter = 100 sq. centimeters = 15.5 sq. inches
 1 sq. meter (centare) = 100 sq. decimeters = 10.76 sq. feet
 1 sq. dekameter (are) = 100 sq. meters = 1,076.4 sq. feet
 1 sq. hectometer (hectare) = 100 sq. dekameters = 2.47 acres
 1 sq. kilometer = 100 sq. hectometers = .386 sq. mile

Cubic Measure

1 cu. centimeter = 1000 cu. millimeters = .06 cu. inch
 1 cu. decimeter = 1000 cu. centimeters = 61.02 cu. inches
 1 cu. meter = 1000 cu. decimeters = 35.31 cu. feet

Approximate Conversion Factors

<i>To change</i>	<i>To</i>	<i>Multiply by</i>	<i>To change</i>	<i>To</i>	<i>Multiply by</i>
inches	centimeters	2.540	ounce-inches	Newton-meters	.007062
feet	meters	.305	centimeters	inches	.394
yards	meters	.914	meters	feet	3.280
miles	kilometers	1.609	meters	yards	1.094
square inches	square centimeters	6.451	kilometers	miles	.621
square feet	square meters	.093	square centimeters	square inches	.155
square yards	square meters	.836	square meters	square feet	10.764
square miles	square kilometers	2.590	square meters	square yards	1.196
acres	square hectometers	.405	square kilometers	square miles	.386
cubic feet	cubic meters	.028	square hectometers	acres	2.471
cubic yards	cubic meters	.765	cubic meters	cubic feet	35.315
fluid ounces	milliliters	29.573	cubic meters	cubic yards	1.308
pints	liters	.473	milliliters	fluid ounces	.034
quarts	liters	.946	liters	pints	2.113
gallons	liters	3.785	liters	quarts	1.057
ounces	grams	28.349	liters	gallons	.264
pounds	kilograms	.454	grams	ounces	.035
short tons	metric tons	.907	kilograms	pounds	2.205
pound-feet	Newton-meters	1.356	metric tons	short tons	1.102
pound-inches	Newton-meters	.11296			

Temperature (Exact)

°F	Fahrenheit temperature	5/9 (after subtracting 32)	Celsius temperature	°C
----	------------------------	----------------------------	---------------------	----

PIN: 074501-000